

Technical Manual
2022

Sprint

5409295 | Rev. 02



/// Olsen

› General Information	03
› Chair	04
Upholsteries and Anti-Stress	05
Sprint	06
Headrest	07
Armrest	08
Base	09
Structure	10
Motor	11
› Delivery Unit	12
Platform	13
Pedal	14
Operating Light Arm - Part I	15
Operating Light Arm - Part II	16
Operating Light - Part I	17
Operating Light - Part II	18
Water Unit - Part I	19
Water Unit - Part II	20
Assistant Module	21
Spittoon Bowl	22
Table Arm - Part I	23
Table Arm - Part II	24
Table Arm - Part III	25
Working Table - Part I	26
Working Table - Part II	27
Instruments and their Components - Part I	28
Instruments and their Components - Part II	29
Instruments and their Components - Part III	30
Instruments and their Components - Part IV	31
Instruments and their Components - Part V	32
Instrument Holder and Coupling Terminals	33

› Parts	34
Hoses	35
Electrical Components	36
Valves and Connections - Part I	37
Valves and Connections - Part II	38
› Information	39
Tools	40
Instructions	41
Troubleshooting Table - Part I	42
Troubleshooting Table - Part II	43
Troubleshooting Table - Part III	44
Troubleshooting Table - Part IV	45
Troubleshooting Table - Part V	46
Troubleshooting Table - Part VI	47
Troubleshooting Table - Part VII	48
Revisions Program	49
Features - Chair	50
Features - Accessories	51
Sprint T- Side View	52
Sprint T- Upper View	53
Sprint - Side View	54
Sprint - Upper View	55
Attachments	56

WELCOME TO SPRINT TECHNICAL MANUAL

Dear technician:

> The main objective of this manual is to facilitate communication between technicians and the factory with regard to the correct identification of parts and components of dental sets.

> The main parts and their components are presented with exploded drawings, showing the smaller parts in detail.

> For correct use of this manual, observe the presentation pattern of the parts and components described in the example below.

> Additional supporting documents can be found in the download section of the website.

The main title bar has links to facilitate navigation between pages. Touch or click on the house icon to return to the table of contents and over the title to return to the main page of the section.



Return to the main page of the section
Return to the table of contents

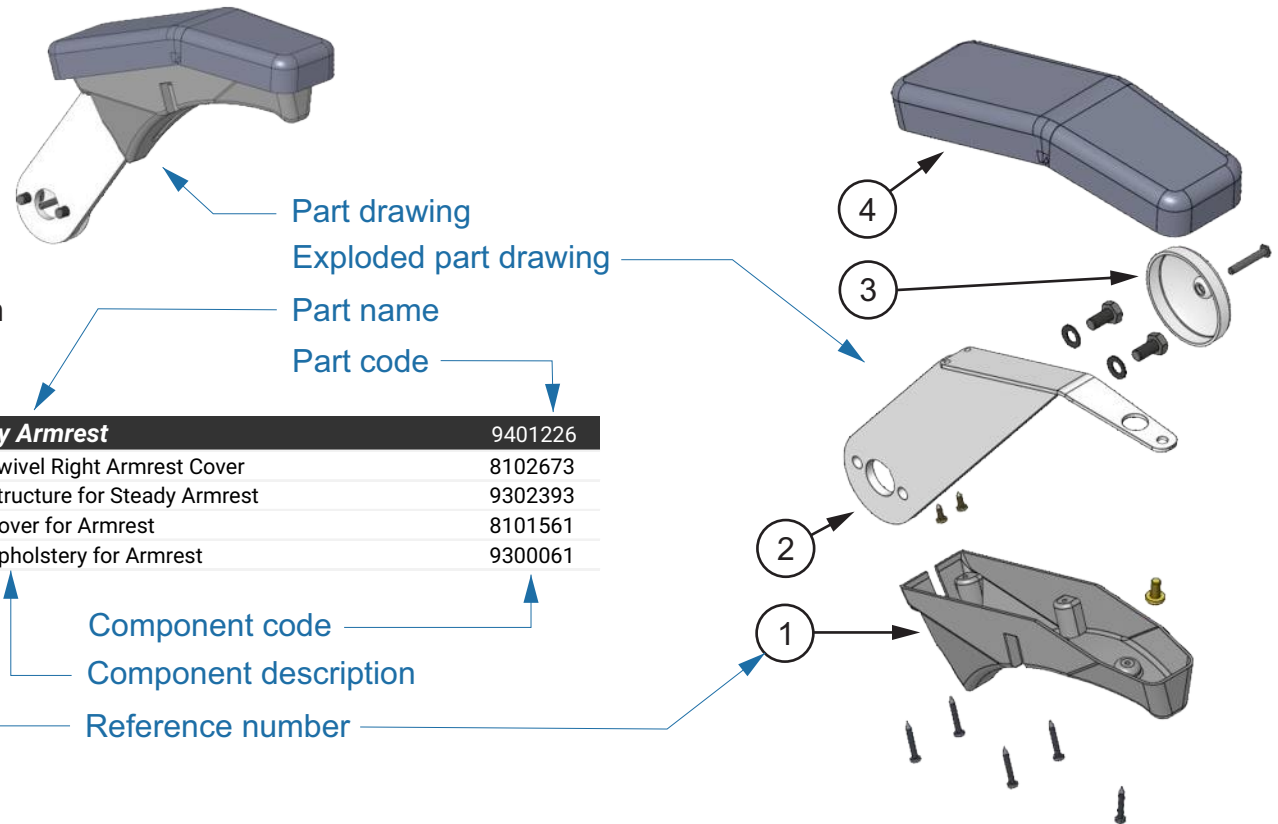

Steady Armrest		9401226
1	Swivel Right Armrest Cover	8102673
2	Structure for Steady Armrest	9302393
3	Cover for Armrest	8101561
4	Upholstery for Armrest	9300061

Component code
Component description
Reference number

Indicative symbols

 - Optional Item

 - Note

INTRODUCTION TO THE PARTS PRESENTED IN THIS SECTION

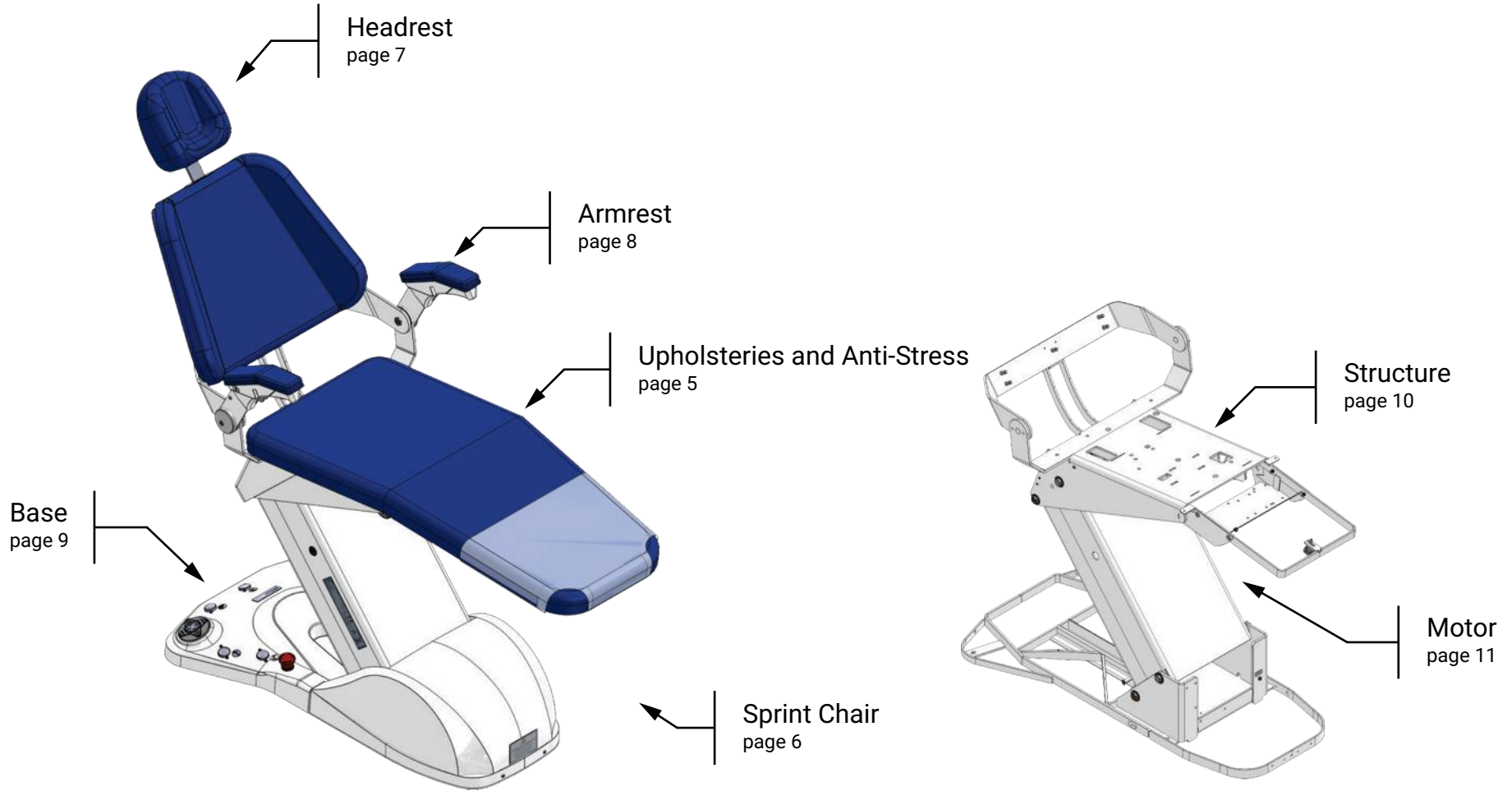

SOFT LAMINATE

ANTI-STRESS

Command for Anti-Stress System

2200792

Leather Upholstery Colors		
Description	Ref	Code
Leather W Wine	CRVINHO	4100832
Leather W Black	CRPRETO	4100832
Leather W SW4 Brown	CRMARRO	4100832
Leather W Hilux Gray	CRCINZA	4100832
Ivory Beige Leather	CRBEGE	4100832
Royal Blue Leather	CRAZULR	4100832

PVC Upholstery Colors		
Description	Ref	Code
White 3D	BRAN 3D	4100699
Gray 3D	CINZ 3D	4100704
Black 3D	PRET 3D	4100708
Cappuccino 3D	CAPC 3D	4100706
Pearl 3D	PERL 3D	4100705
Wine 3D	VINHO 3	4100795
Royal Blue 3D	AZUL 3D	4100794
Royal blue	AZUL MH	4100715
Blue Fact	AZUL FC	4100713
Gray Fact	CINZ FC	4100710
Citrus Green	V 11DVC	4100756
Emerald	ESMERAL	4100711
Champagne	CHAMPAG	4100709
Sepia	SEPIA	4100776
Coffee	CAFE	4100771
Red	VERMELH	4100700
Wine	VINHO	4100701
Light green	VER 5DV	4100755
Pink 3D Mini Bling	ROSA 3D	4100838

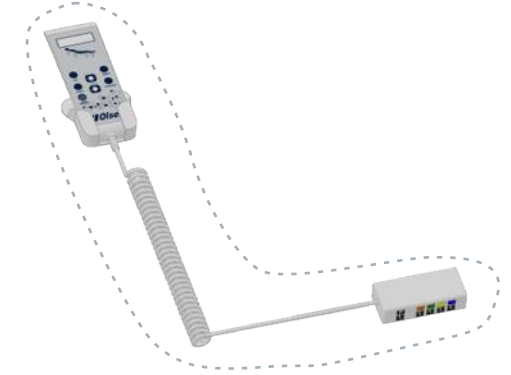
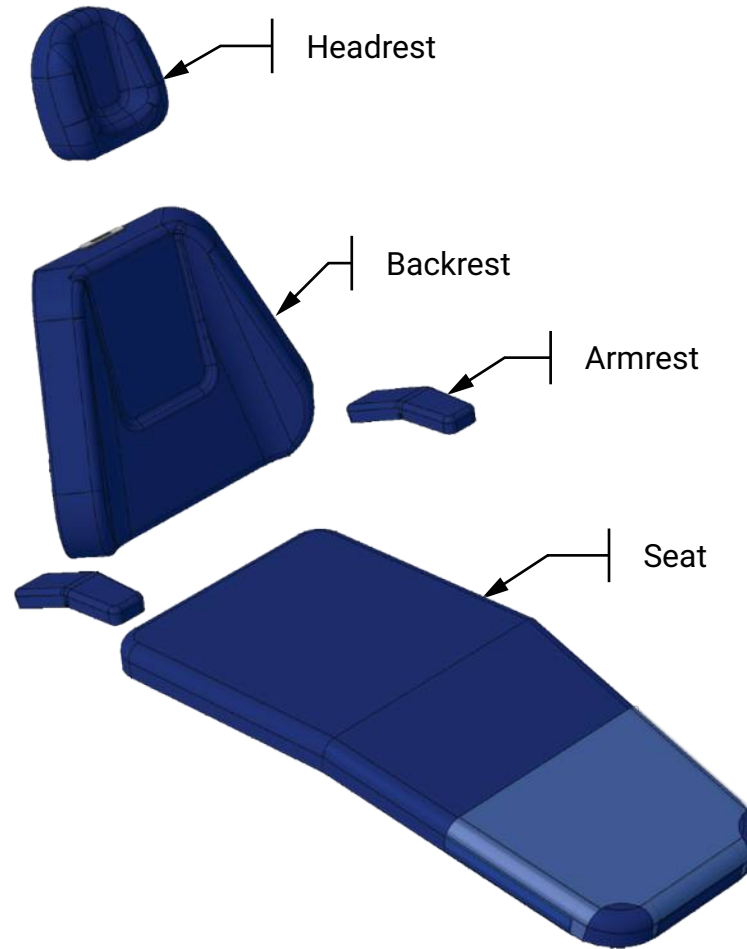

Upholstery	PVC	Leather	Anti-Stress + PVC	Anti-Stress + Leather
Multiarticulated Headrest	4100824	9401230	-	-
Armrest	9300061	9401470	-	-
Seat	9400863	9401413	9303052	9401478
Backrest	9500698	9500820	9500832	9500837

SPRINT CHAIR

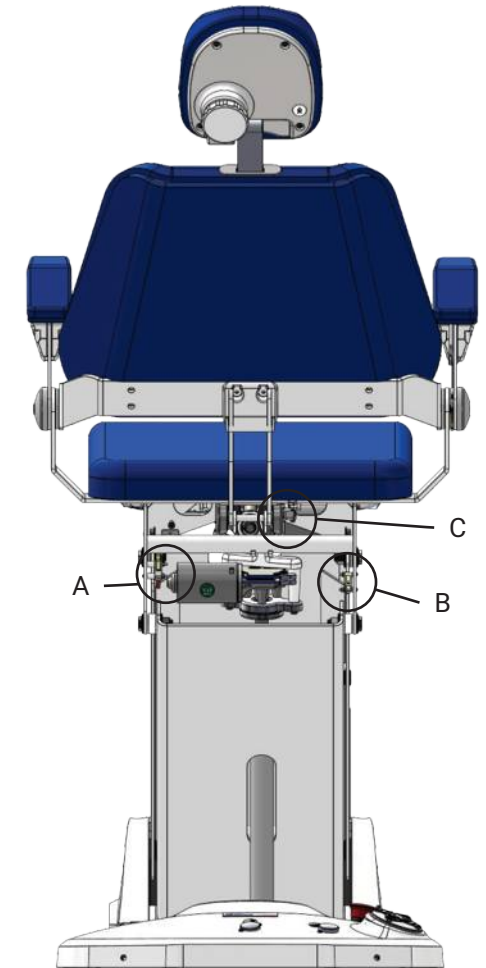
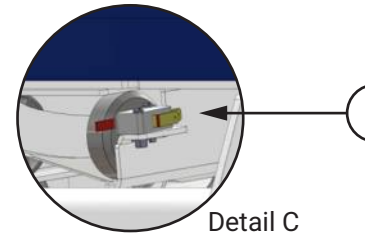
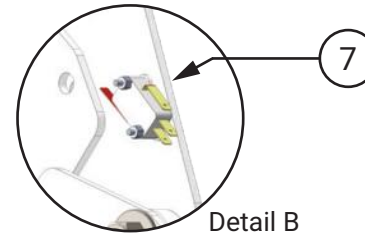
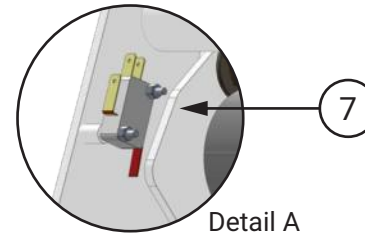

Chair		
1	Base Cover Assembly with SPS 22 Controller	9401512
2	Sprint Seat Fork Cover	9302337
3	Multiarticulate Head Rest	970020003
4	Right-handed Armrest Set Swivel + Steady	970040015
5	Handle MTM 3522 M6 x 20 Gray	9301031
6	Pre-Assembly Bubble Cover SPS 19	9401438
7	Micro Switch BR15IL - QACS	2200277

ARTICULATED HEADREST

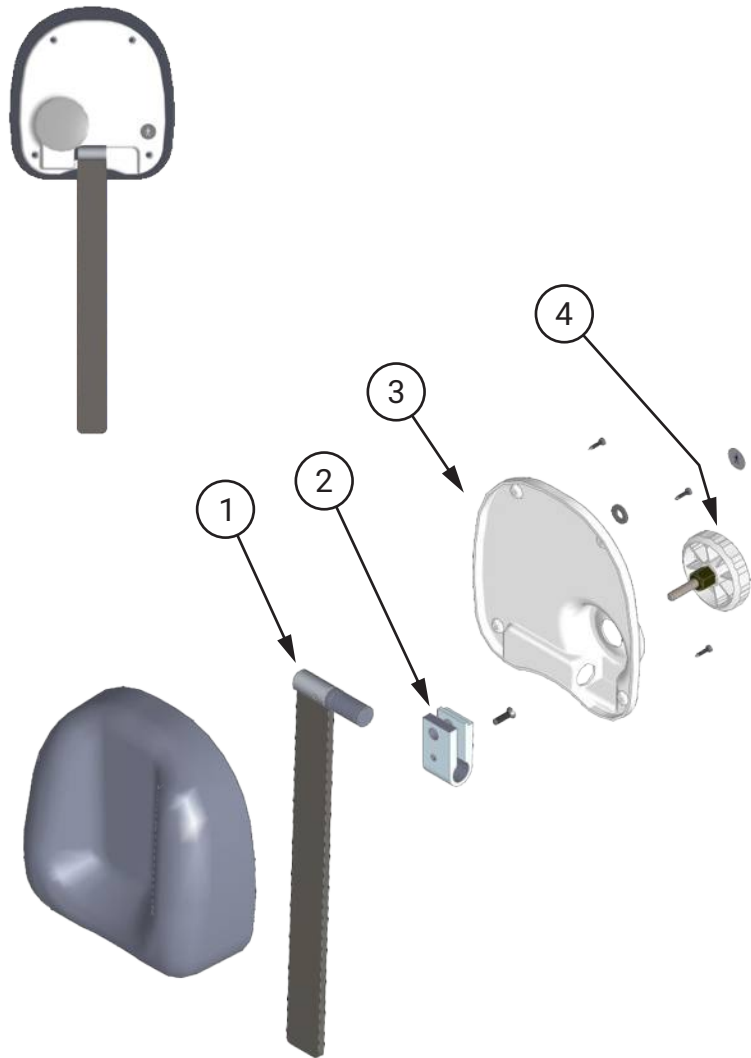

Articulated Headrest 970020002

1	Headrest Lever	9401402
2	Headrest Holder	8200755
3	Articulated Headrest Cover	8101633
4	Articulated Headrest Handle	9301070

MULTIARTICULATED HEADREST

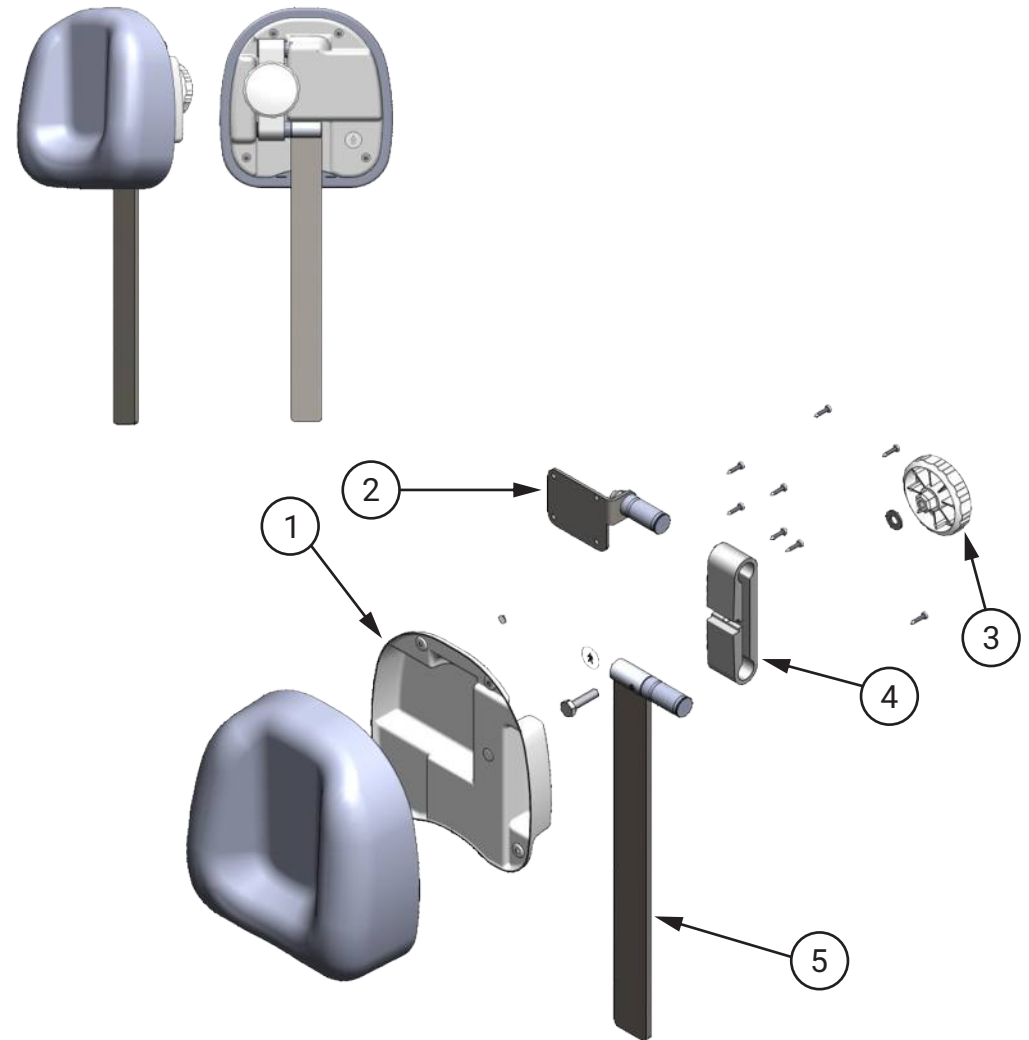

Multiarticulated Headrest 970020003

1	Multiarticulated Headrest Cover	8101631
2	Headrest Support	9302815
3	Headrest Handle Screw	9300925
4	Headrest Holder	8200512
5	Headrest Lever	9401402

STEADY ARMREST

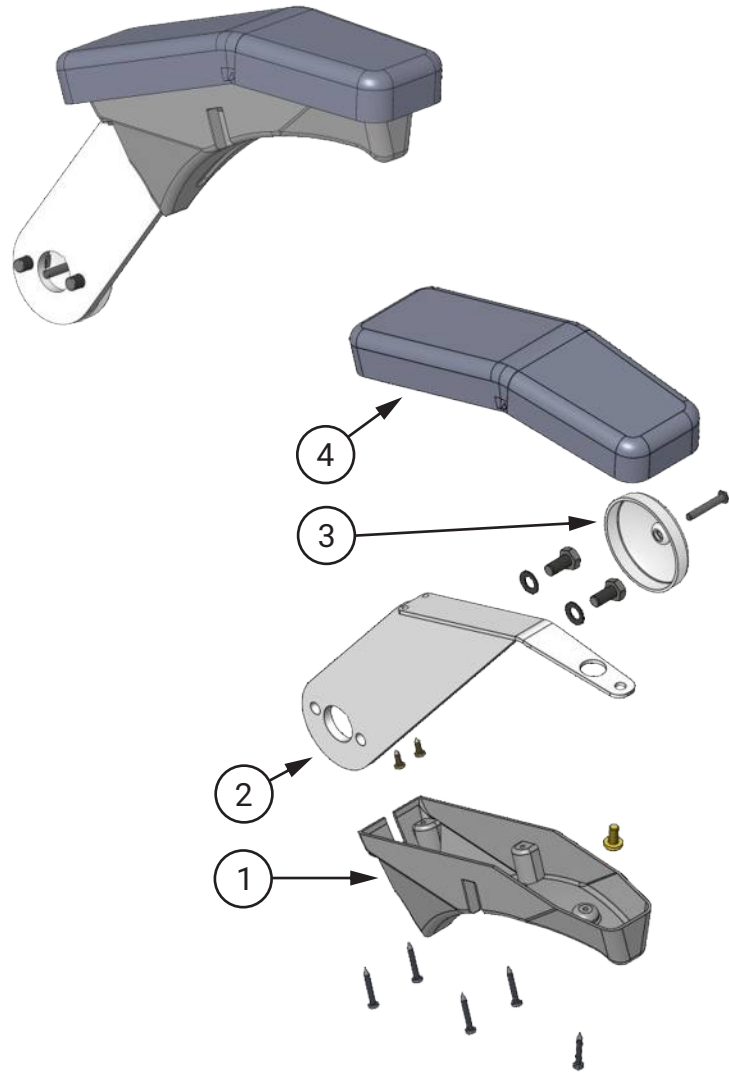

	Right-handed	Left-handed	
Steady Armrest			
1	Steady Right Armrest Cover	8102673	8101241
2	Steady Armrest Structure	9302393	
3	Cover for Armrest	8101561	
4	Upholstery for Armrest	9300061	

SWIVEL ARMREST

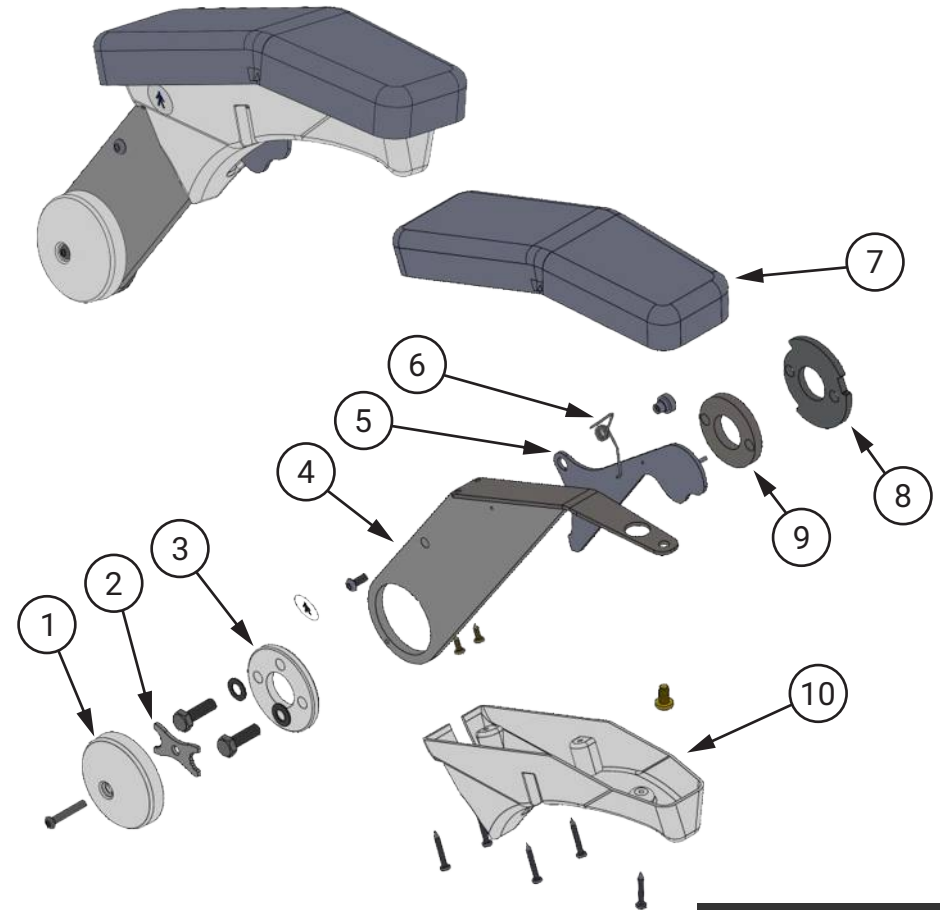

	Right-handed	Left-handed	
Swivel Armrest			
1	Cover for Armrest	8101561	
2	Swivel Armrest Screw Lock	8002699	
3	Swivel Armrest Fixed Flange	8102342	
4	Swivel Armrest Structure	9302394	
5	Long Arm Trigger	8003197	
6	Trigger Spring	5200069	5201724
7	Upholstery for Armrest	9300061	
8	Swivel Armrest Flange	8002930	
9	Inner Armrest Flange	8002838	
10	Swivel Right Armrest Cover	8102672	8101147

BASE COVER

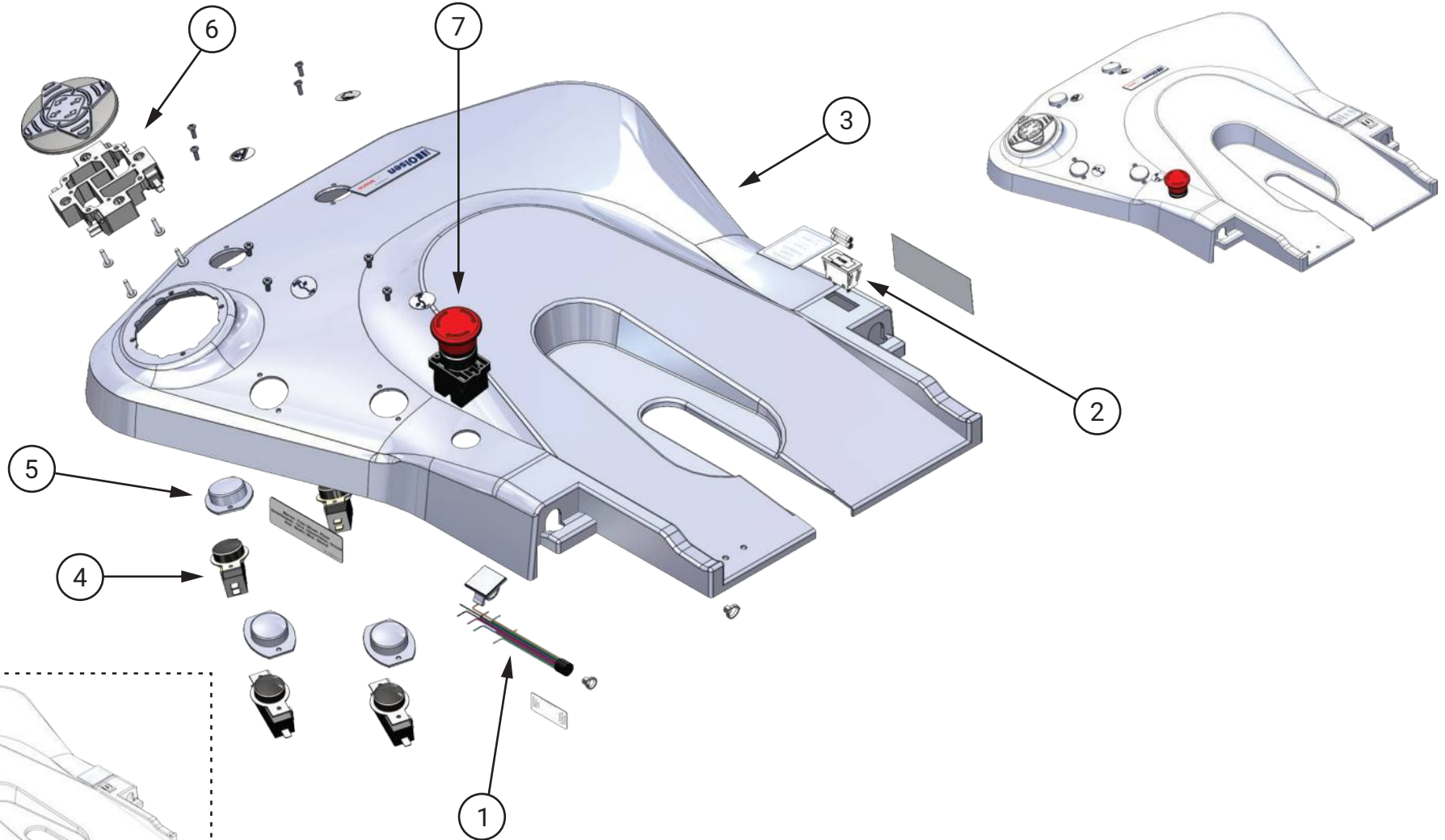

! Cover used when equipped with the optional Remote Foot Pedal

Base Cover Assembly SPS 22 9401511

Base Cover Assembly with Command SPS 22		9401512
1	Electric Cable SPS 22	9303262
2	Rectangular Fuse Holder - White MBTBW1	2200911
3	Base Cover with Command SPS 22	8103068
4	Microswitch MG-2608 IR / E3G 20A	2200186
5	Button Cover	8101533
6	Electric Drive Pedal	9302557
7	Emergency Switch	2200396

CHAIR STRUCTURE

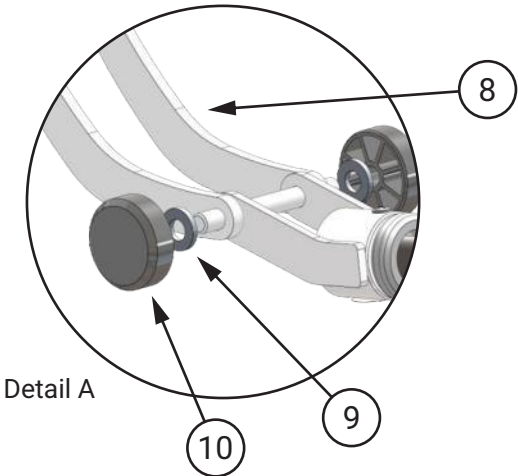
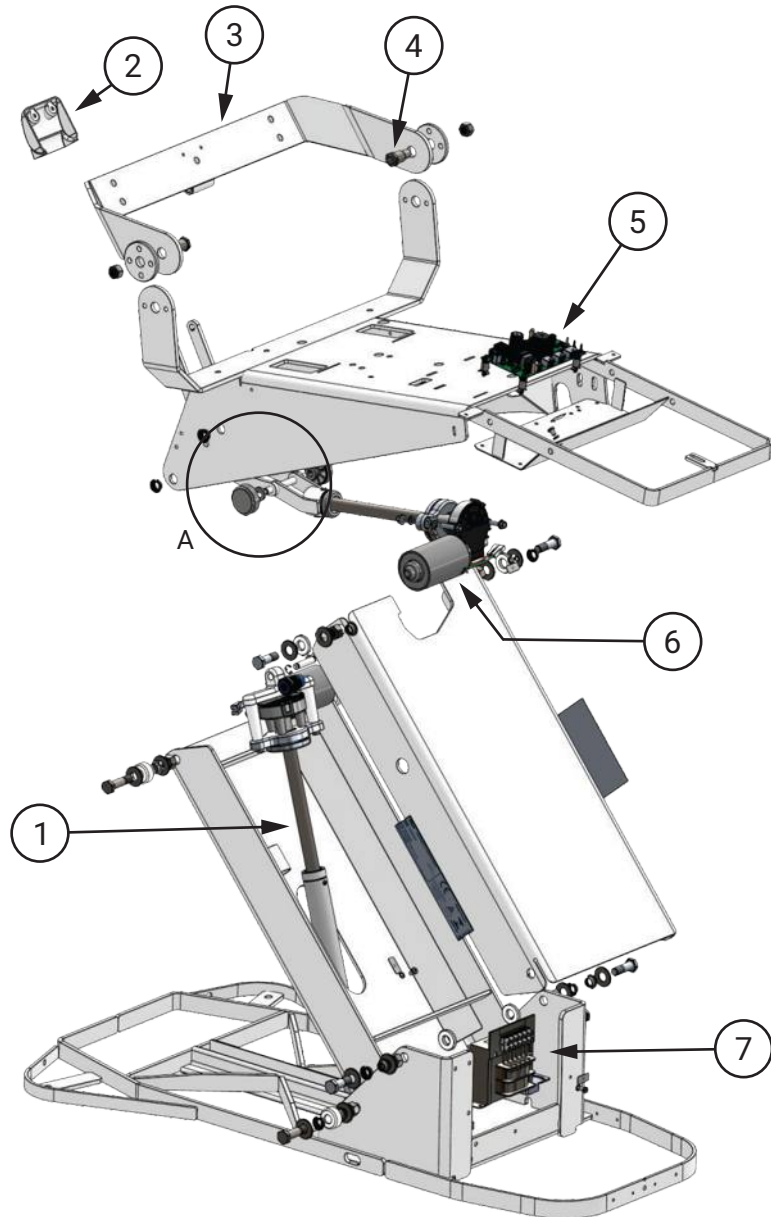

Chair Structure 22		
1	Chair Lift Motor SPSL PPG 19	9401281
2	Cover for Upper Joint Logic/IN	8102436
3	Upper Backrest Joint Siena/Sprint 2016	9302189
4	Backrest Pivot Axle SPS 20	8003437
5	SPS Dental CPU Board with Integrated LED Drive (without Touch)	2200909
6	Backrest Tilt Motor SPSLI 19	9401188
7	SMC Transformer 124,2VA 0/118V/127V/220V/230V 0,6KV 50/60HZ	2200914
8	Backrest Movement Rod 17	8002893
9	Backrest Motor Spacer	8102406
10	Pulley	8100051

SEAT SPINDLE MOTOR



Seat Spindle Motor

9401281

1 DIN Pin 7

5201408

BACKREST SPINDLE MOTOR

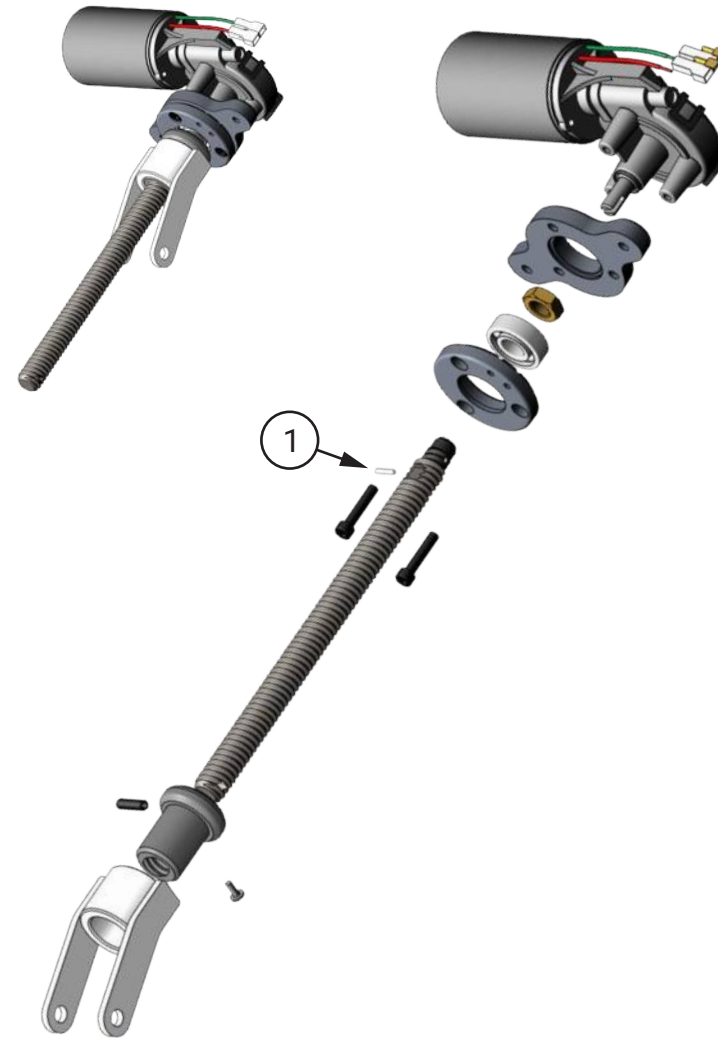

Backrest Spindle Motor

9401188

1 DIN Pin 7

5201408

INTRODUCTION TO THE PARTS PRESENTED IN THIS SECTION

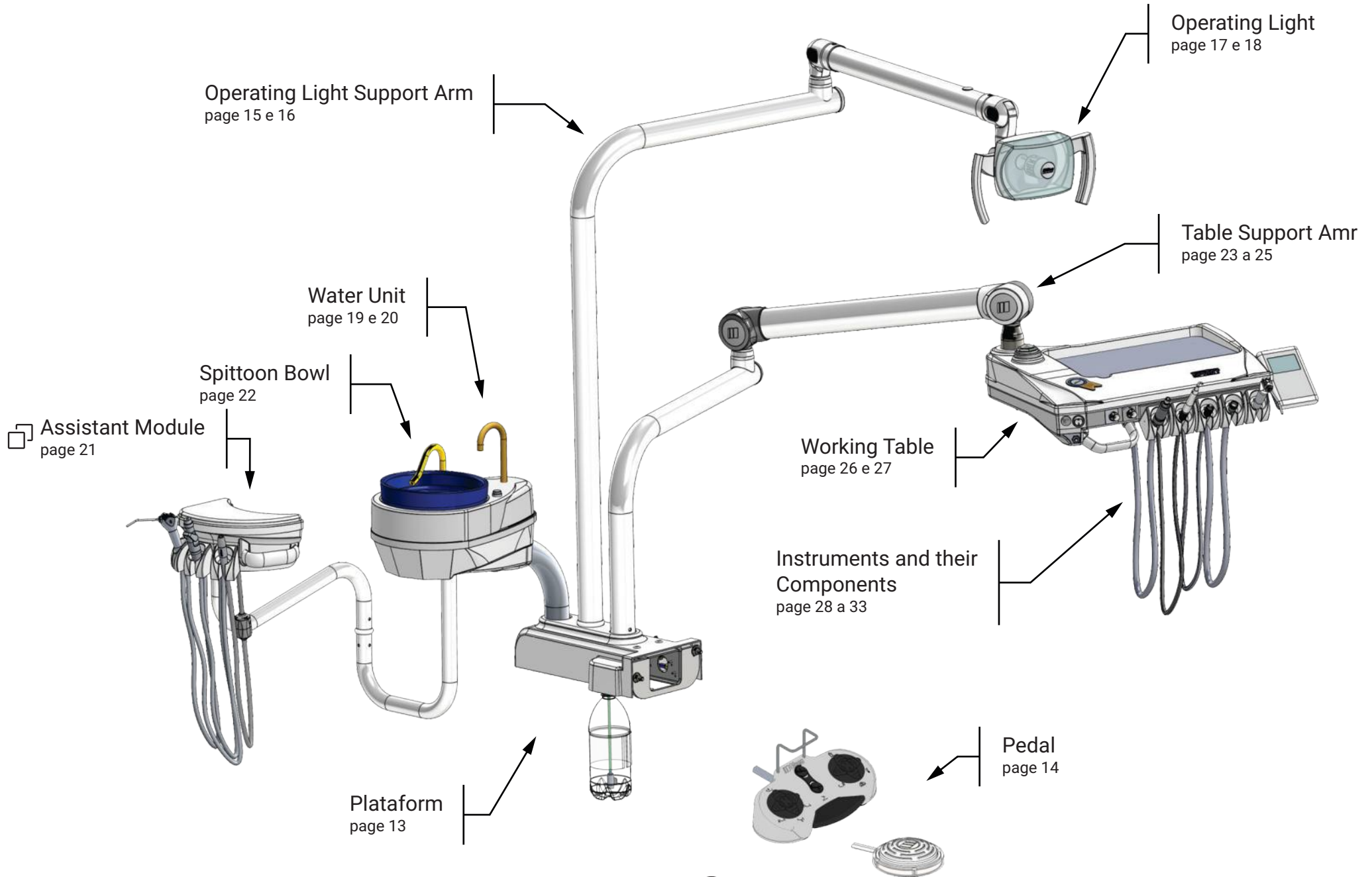

PLATFORM

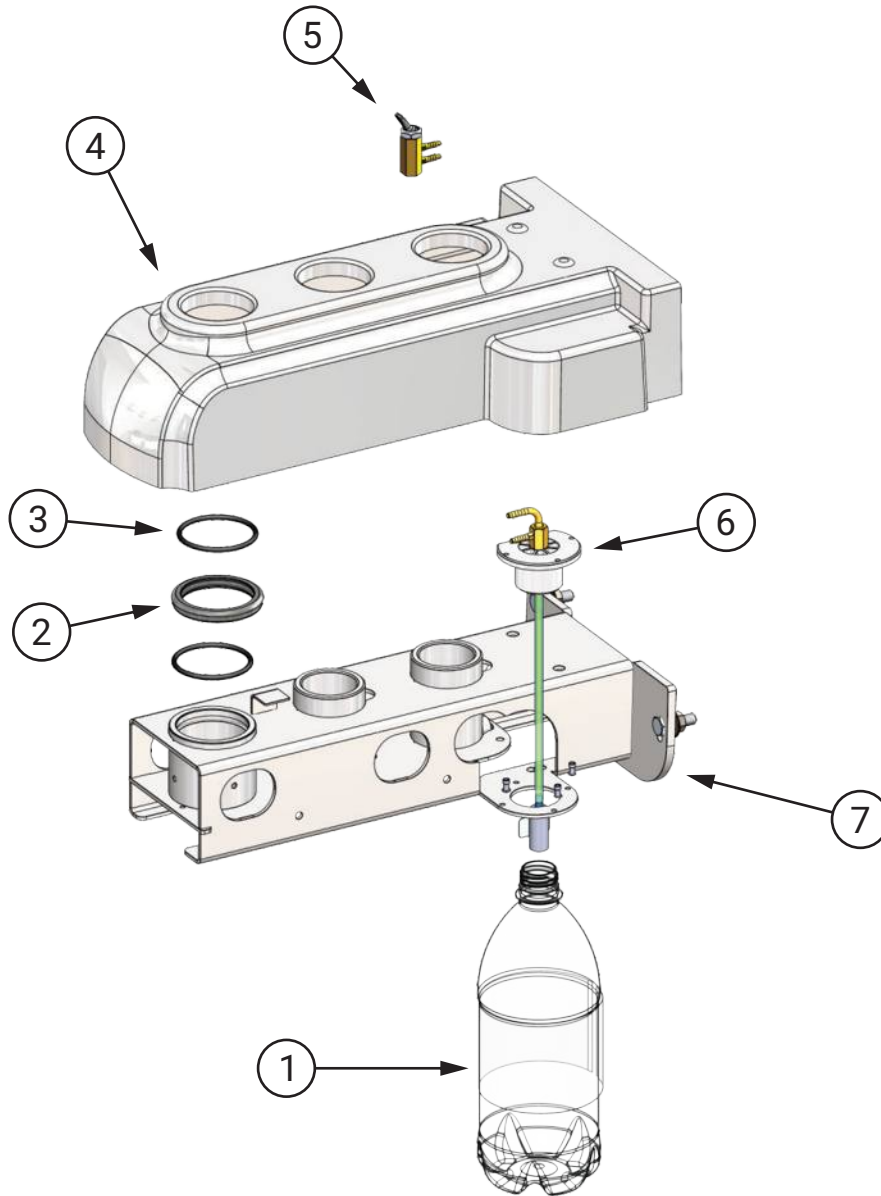

Siena / Sprint Tank Filter Kit		9401202
8	Tank Cover Connection 1.4 Kart	9300285
9	Tank Cap w / Cut	8101138
10	O'ring ref. 2213	3000110
11	Tank Water Filter	3100162

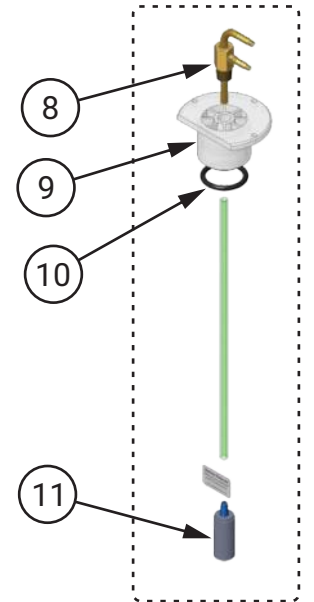

Platform		
1	Tank with Adhesive	9302295
2	UNA Sprint 18 Arm Flange	8102451
3	O'Ring Ref. 2-226 Ø50.39 x W3.5	3100210
4	Platic Cover Platform Angled Arm SP 19	8102755
5	Air Valve Click	9302478
6	Tank Filter Kit Siena / Sprin	9401202
7	Platform Structure SPS 22	9303275

📄 REMOTE FOOT PEDAL

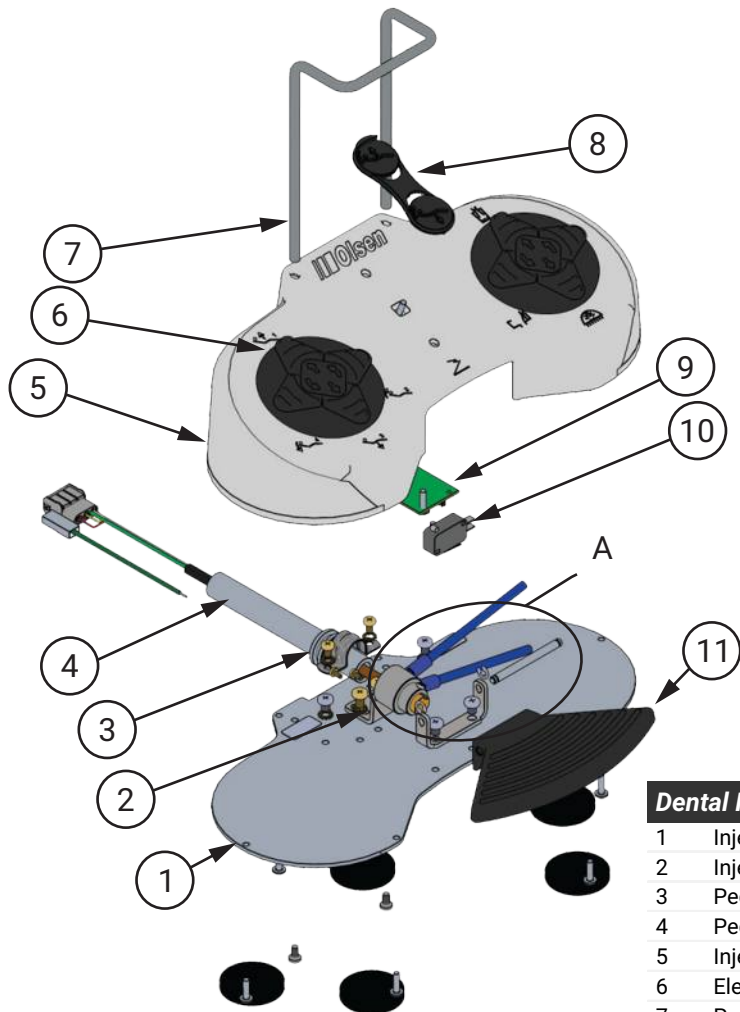

Dental Remote Foot Pedal Sprint/Siena/Quality 19 9500869

1	Injected Pedal Base	8002686
2	Injected Pedal Valve Support	8002687
3	Pedal Finishing Ring	8102377
4	Pedal Finishing Hose	8100226
5	Injected Cover Pedal	8102299
6	Electric Drive Pedal	9302557
7	Painted Handle Injected Pedal	8002864
8	Automatic Pedal Adjustment Actuator	8102308
9	Pedal PC Board Serial R 232	2200781
10	Micro Switch Gray CX-FL8-39	999500090
11	Injected Pedal Propulsion Driver	9302355
12	Logic Progressive Valve	9400635
13	Shaft Propulsion Support	8002688
14	Propulsion Shaft	8201240

PROGRESSIVE PEDAL

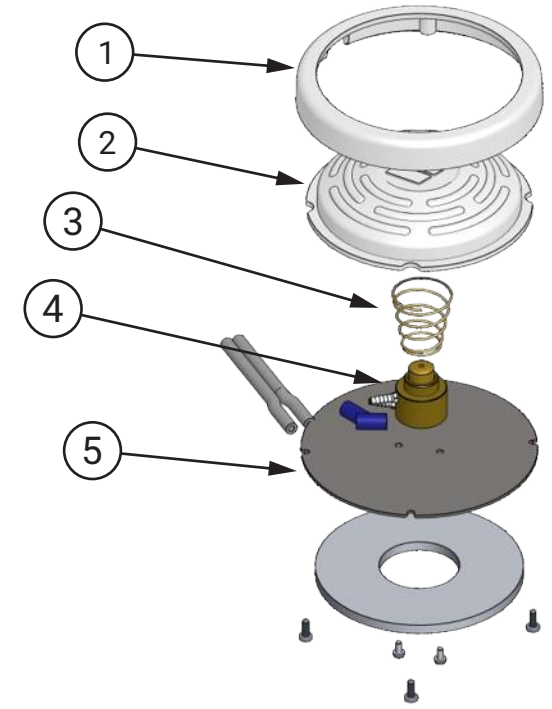

Siena Progressive Pedal 9500619

1	Injected Pedal Rim	8101763
2	Injected Pedal Trigger Button	8101764
3	Progressive Pedal Conical Spring	5201710
4	Olsen Progressive Actuation Valve	9401021
5	Pedal Base Cover	8002180

EVOLUTION PLUS OPERATING LIGHT SUPPORT ARM

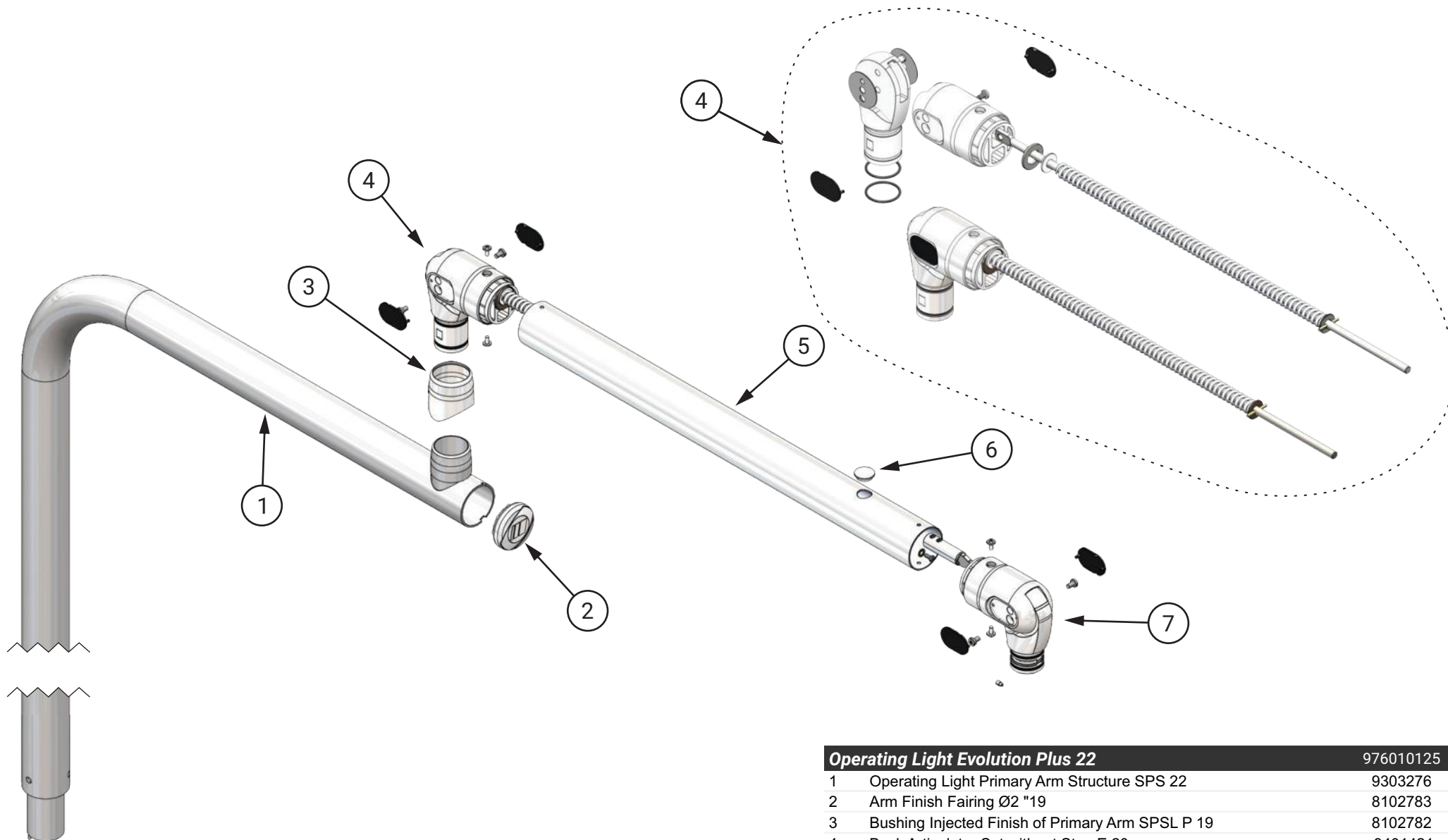

Operating Light Evolution Plus 22		976010125
1	Operating Light Primary Arm Structure SPS 22	9303276
2	Arm Finish Fairing Ø2 "19	8102783
3	Bushing Injected Finish of Primary Arm SPSL P 19	8102782
4	Back Articulator Set without Stop E 20	9401421
5	Operating Light Secondary Arm Structure E 20	9303048
6	Finishing Cap for Ø16 holes	8101758
7	Frontal Articulator Set E 20	9401461

LED PREMIUM AND CONCEPT PLUS OPERATING LIGHT SUPPORT ARM

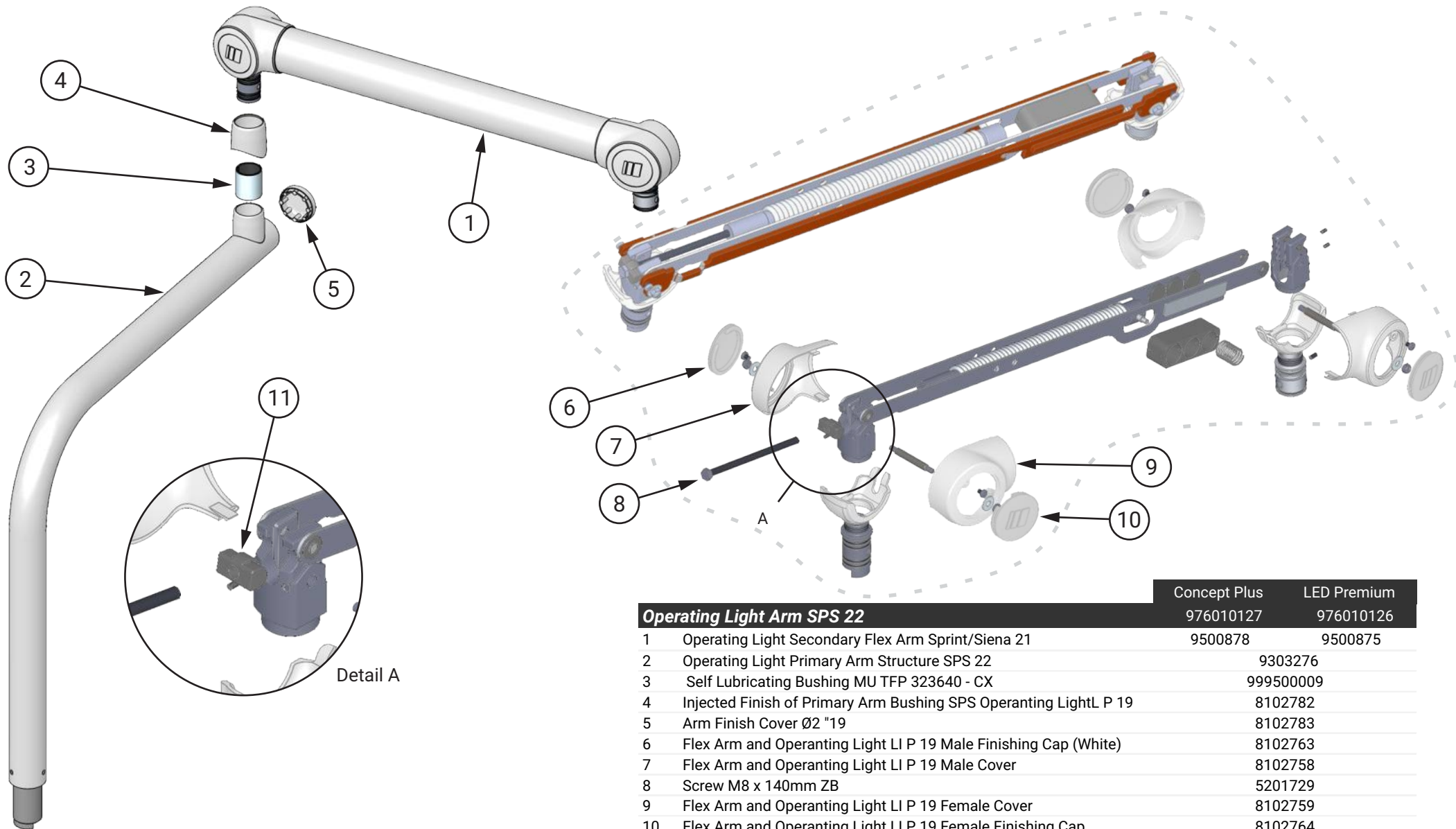

		Concept Plus	LED Premium
Operating Light Arm SPS 22		976010127	976010126
1	Operating Light Secondary Flex Arm Sprint/Siena 21	9500878	9500875
2	Operating Light Primary Arm Structure SPS 22		9303276
3	Self Lubricating Bushing MU TFP 323640 - CX		999500009
4	Injected Finish of Primary Arm Bushing SPS Operanting LightL P 19		8102782
5	Arm Finish Cover Ø2 "19		8102783
6	Flex Arm and Operanting Light LI P 19 Male Finishing Cap (White)		8102763
7	Flex Arm and Operanting Light LI P 19 Male Cover		8102758
8	Screw M8 x 140mm ZB		5201729
9	Flex Arm and Operanting Light LI P 19 Female Cover		8102759
10	Flex Arm and Operanting Light LI P 19 Female Finishing Cap		8102764
11	Spring Adjuster 18		8102296

EVOLUTION PLUS OPERATING LIGHT

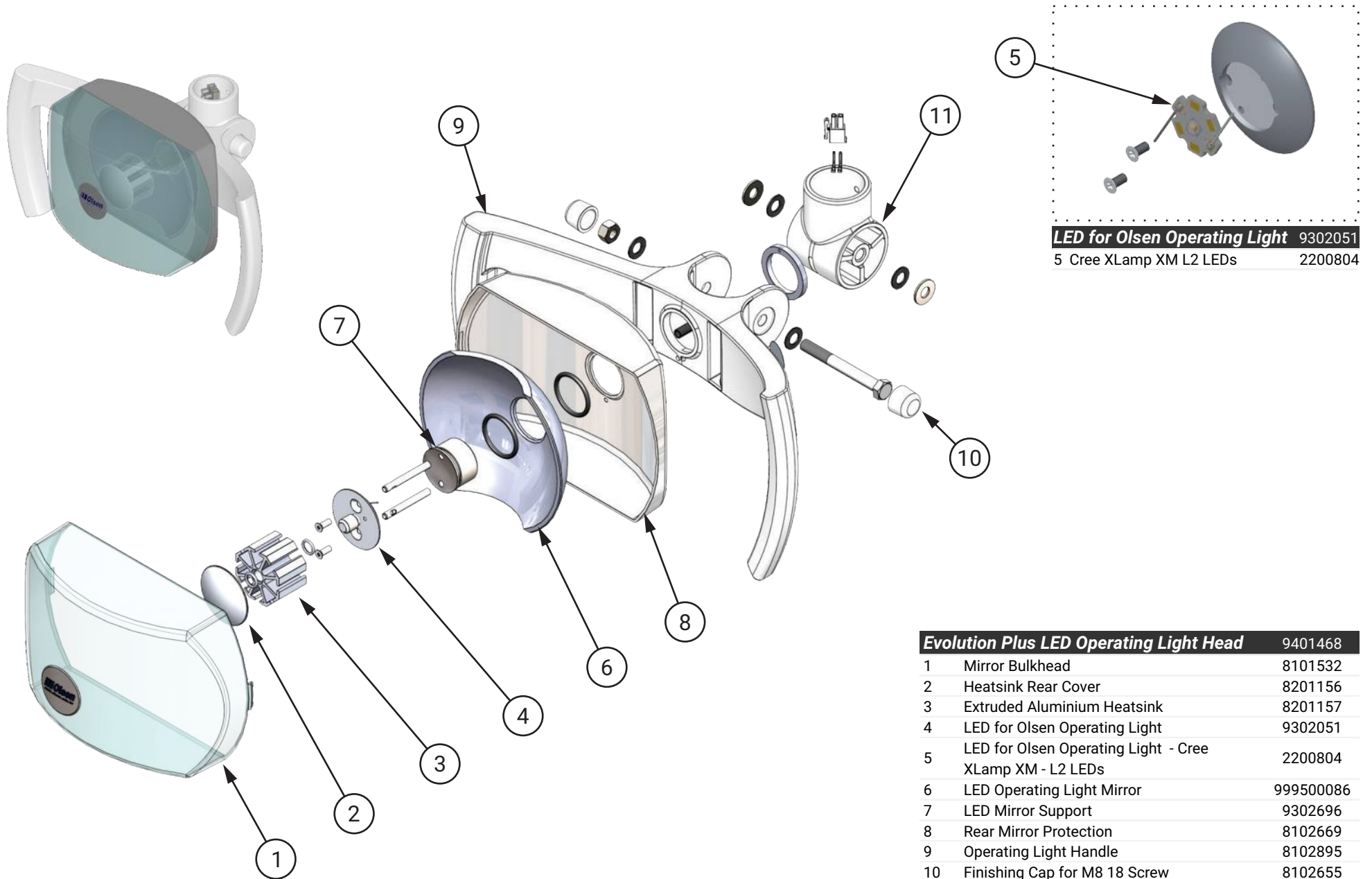

LED for Olsen Operating Light 9302051
5 Cree XLamp XM L2 LEDs 2200804

Evolution Plus LED Operating Light Head 9401468		
1	Mirror Bulkhead	8101532
2	Heatsink Rear Cover	8201156
3	Extruded Aluminium Heatsink	8201157
4	LED for Olsen Operating Light	9302051
5	LED for Olsen Operating Light - Cree XLamp XM - L2 LEDs	2200804
6	LED Operating Light Mirror	999500086
7	LED Mirror Support	9302696
8	Rear Mirror Protection	8102669
9	Operating Light Handle	8102895
10	Finishing Cap for M8 18 Screw	8102655
11	Operating Light Support	8102896

📄 CONCEPT PLUS OPERATING LIGHT

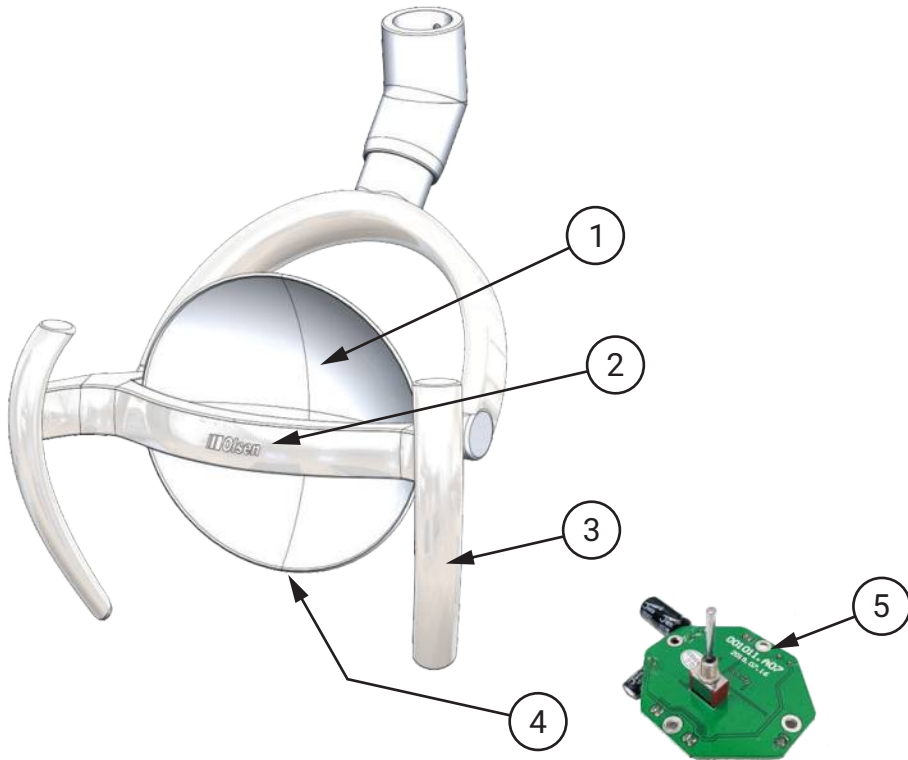

Concept Plus Operating Light 999500095

1	Concept Plus Operating Light Mirror CX-249-21	999600014
2	Operating Light LED Model CX249-22	999500144
3	Operating Light Side Handle CX 249-21	999500242
4	Operating Light sensor PC board CX 249-21	999500241
5	Concept Plus Operating Light PC Board	999500145

PREMIUM OPERATING LIGHT 📄



Premium Operating Light 999500039

1	Mirror for Operating Light CX-249-22	999600011
2	LED for Operating Light CX249-22	999500144
3	Premium Operating Light Sensor PC Board CX249-22	999600013
4	Operating Light PC Board CX249-22	999500023

WATER UNIT - ST

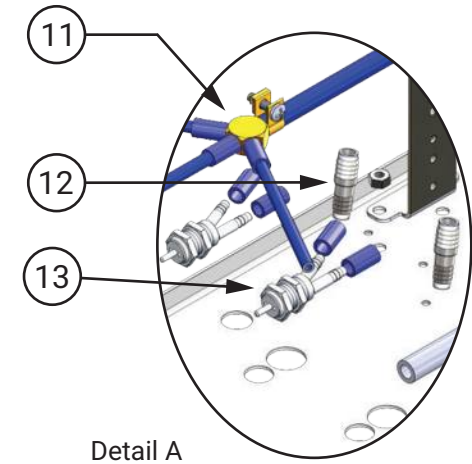
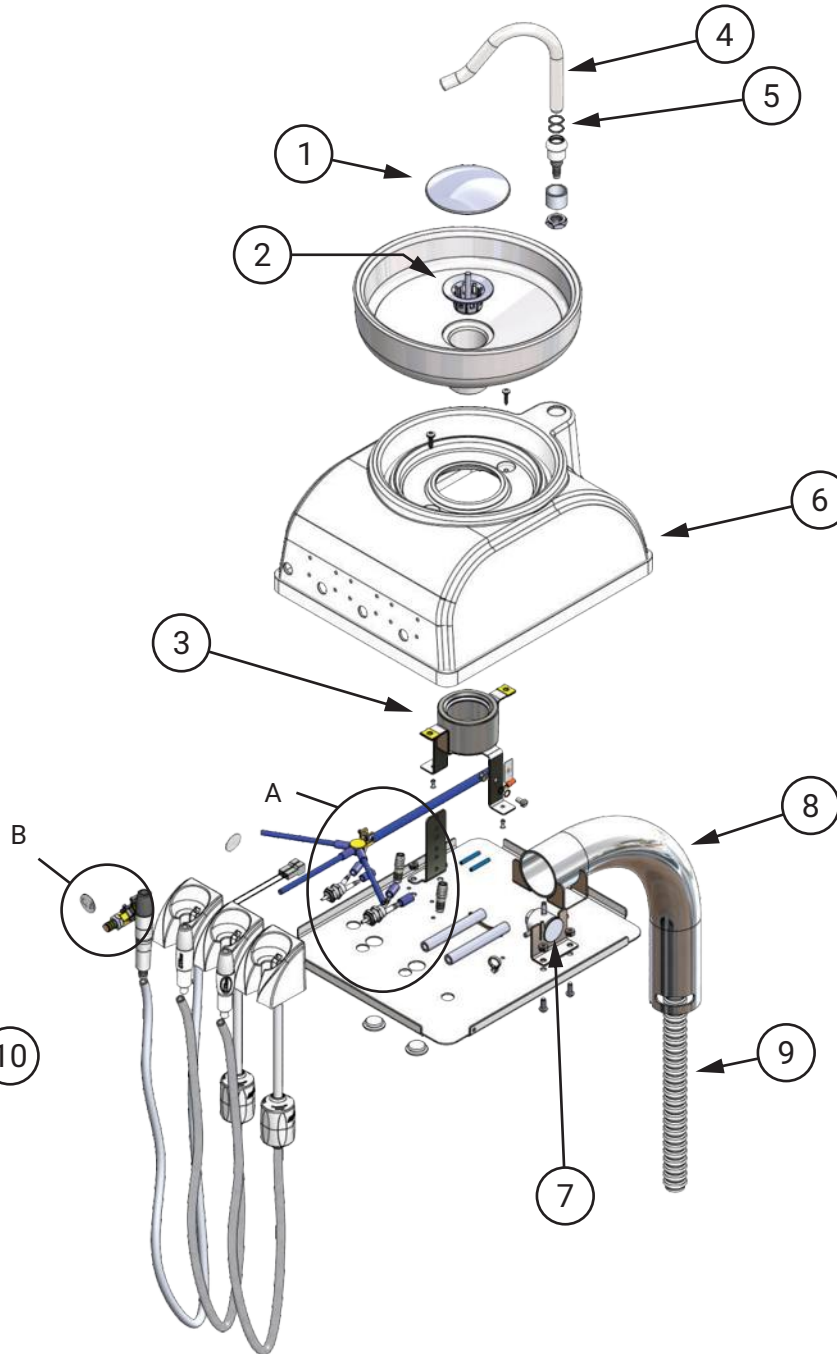
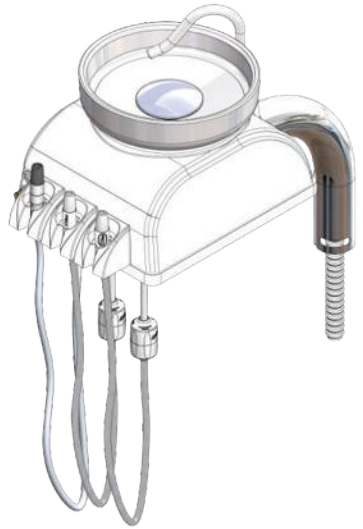

Detail A

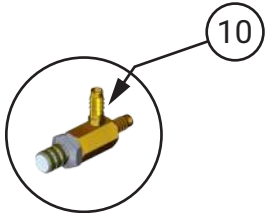

Detail B

Water Unit ST 18		UNA-ST 002
1	Injected Bowl Finish	8102176
2	Bowl Drain 18	8102649
3	Spittoon Bowl support T 19	9302852
4	Tube Body Ø1 / 2" from Integrated Spittoon Bowl	8200725
5	O'Ring Nitrile	3000122
6	Water Unit Cover Sprint T 19	8102776
7	Reduction Valve	3100121
8	Structure UNA Sprint 18	9302506
9	Gray Corrugated Hose Ø19x3100mm	8102457
10	Complete Water Valve	9400077
11	1x3 Way Distributor	9300111
12	Double Spike	8200895
13	Support Valve	3200121

WATER UNIT - SQF

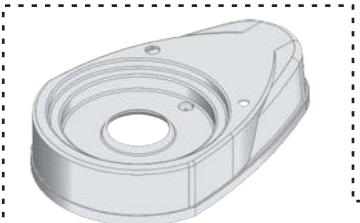
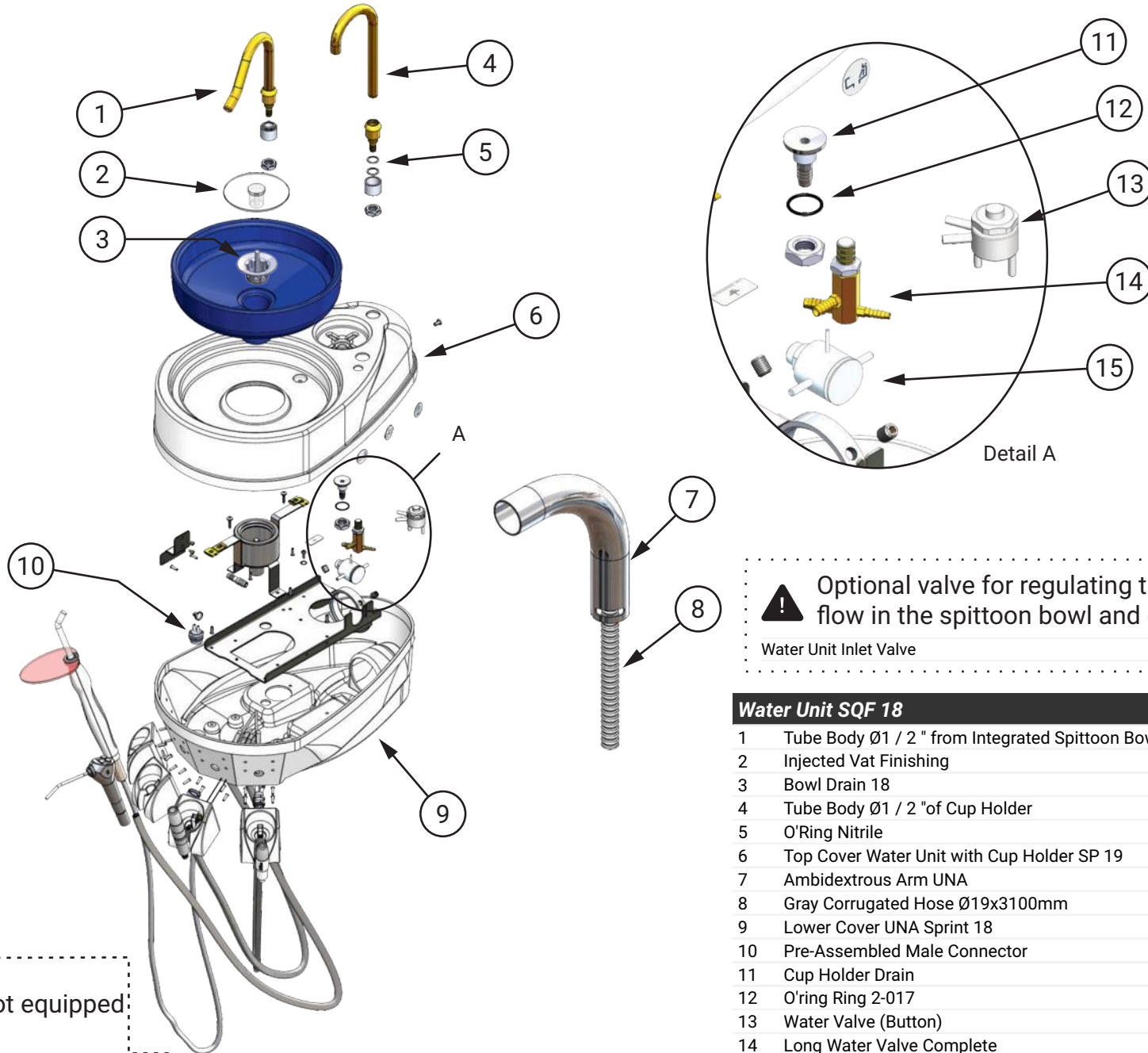

⚠️ Cover used when it is not equipped with the cup holder.

Water Unit Top Cover Without Cup Holder SP 19 8102789

⚠️ Optional valve for regulating the timed water flow in the spittoon bowl and cup holder
 Water Unit Inlet Valve 9401020

Water Unit SQF 18 UNA-SQF 004

1	Tube Body Ø1 / 2 " from Integrated Spittoon Bowl	8200725
2	Injected Vat Finishing	8102176
3	Bowl Drain 18	8102649
4	Tube Body Ø1 / 2 "of Cup Holder	8201036
5	O'Ring Nitrile	3000122
6	Top Cover Water Unit with Cup Holder SP 19	8102774
7	Ambidextrous Arm UNA	8002923
8	Gray Corrugated Hose Ø19x3100mm	8102457
9	Lower Cover UNA Sprint 18	8102448
10	Pre-Assembled Male Connector	9301477
11	Cup Holder Drain	8200120
12	O'ring Ring 2-017	3000101
13	Water Valve (Button)	3100136
14	Long Water Valve Complete	9400557
15	Flex Reduction Valve	3100160

📄 WATER UNIT WITH ASSISTANT MODULE

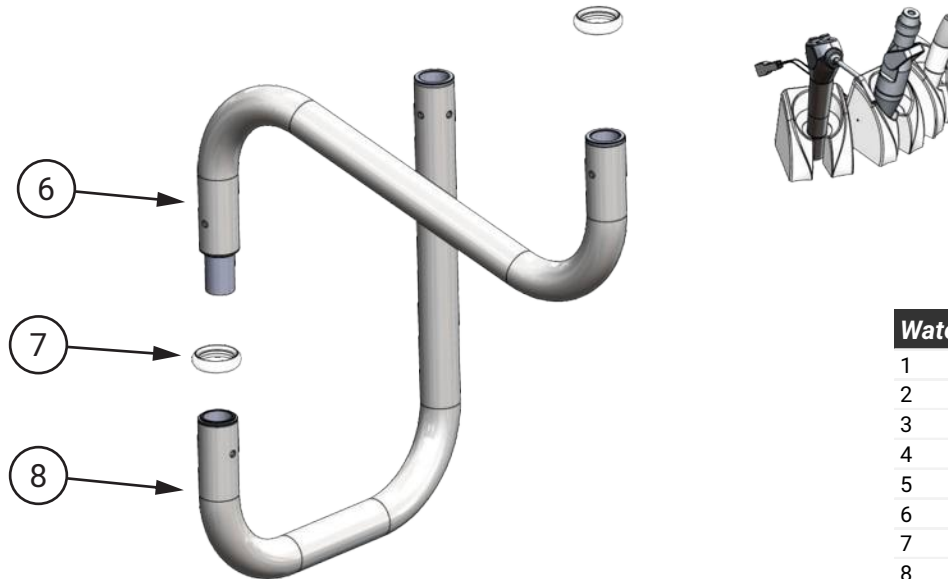
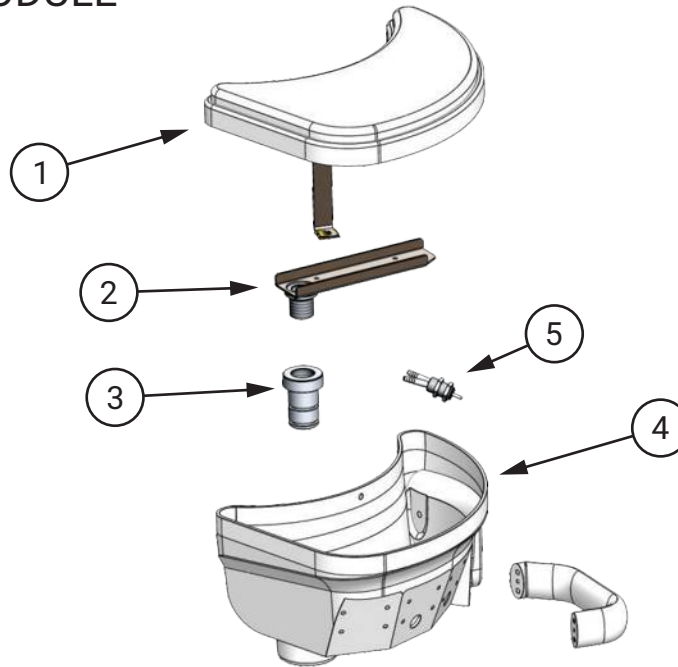

Water Unit with Assistant Module SQ 16		UNA-SQF 004
1	Upper Cover of Siena Module 19	8102748
2	Siena Module Structure	9302214
3	Regulation Bushing Modulo Siena	8102246
4	Lower Cover of Siena Module 19	8102749
5	Support Valve	3200121
6	Secondary Arm Siena Module	9302203
7	Siena Module Finishing Ring	8102249
8	Primary Arm of the Siena Module	9302202

TRANSLUCENT SPITTOON BOWL

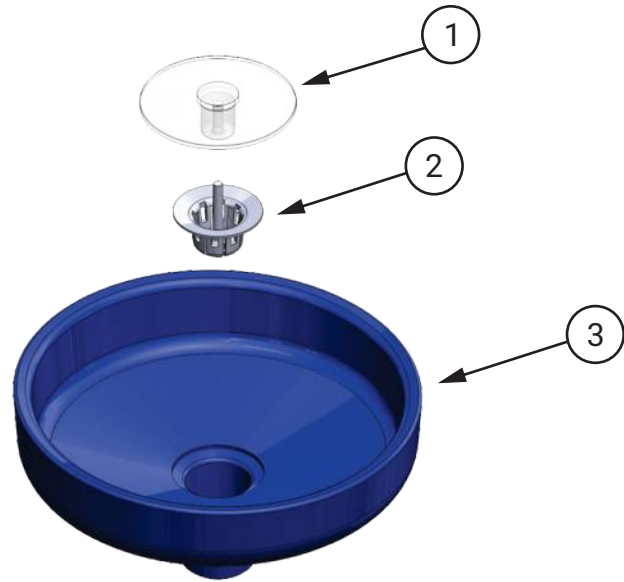

Components of Translucent Spittoon Bowl

1	Injected Bowl Finish	8102176
2	Bowl Drain 18	8102649

Spittoon Bowl Color Code

3	Polyester Bowl Champagne Solid	1600442
	Polyester Bowl Rose Solid	1600443
	Polyester Bowl Wine Solid	1600444
	Polyester Bowl Grey Solid	1600445
	Polyester Bowl Black Solid	1600446
	Polyester Bowl Citrus Green Solid	1600447
	Polyester Bowl Champagne Solid	1600448
	Polyester Bowl Royal Blue Solid	1600449
	Polyester Bowl White Solid	1600450

PORCELAIN SPITTOON BOWL

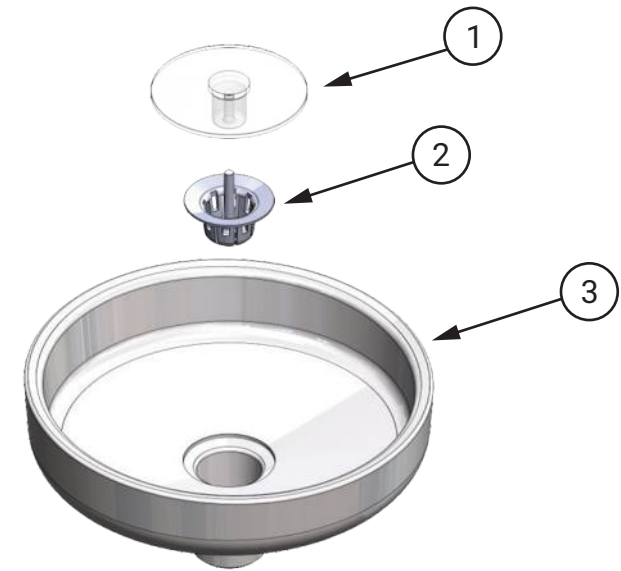

Porcelain Spittoon Bowl

1	Injected Bowl Finish	8102176
2	Drain for Porcelain Spittoon Bowl	8102853
3	Porcelain Spittoon Bowl	1600078

TABLE SUPPORT ARM - ANGLED

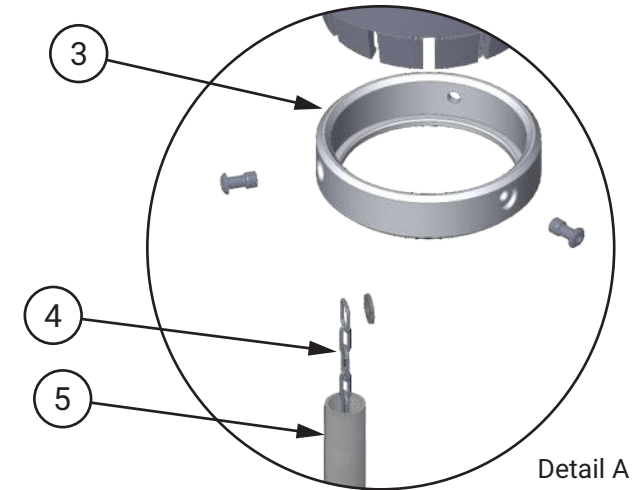
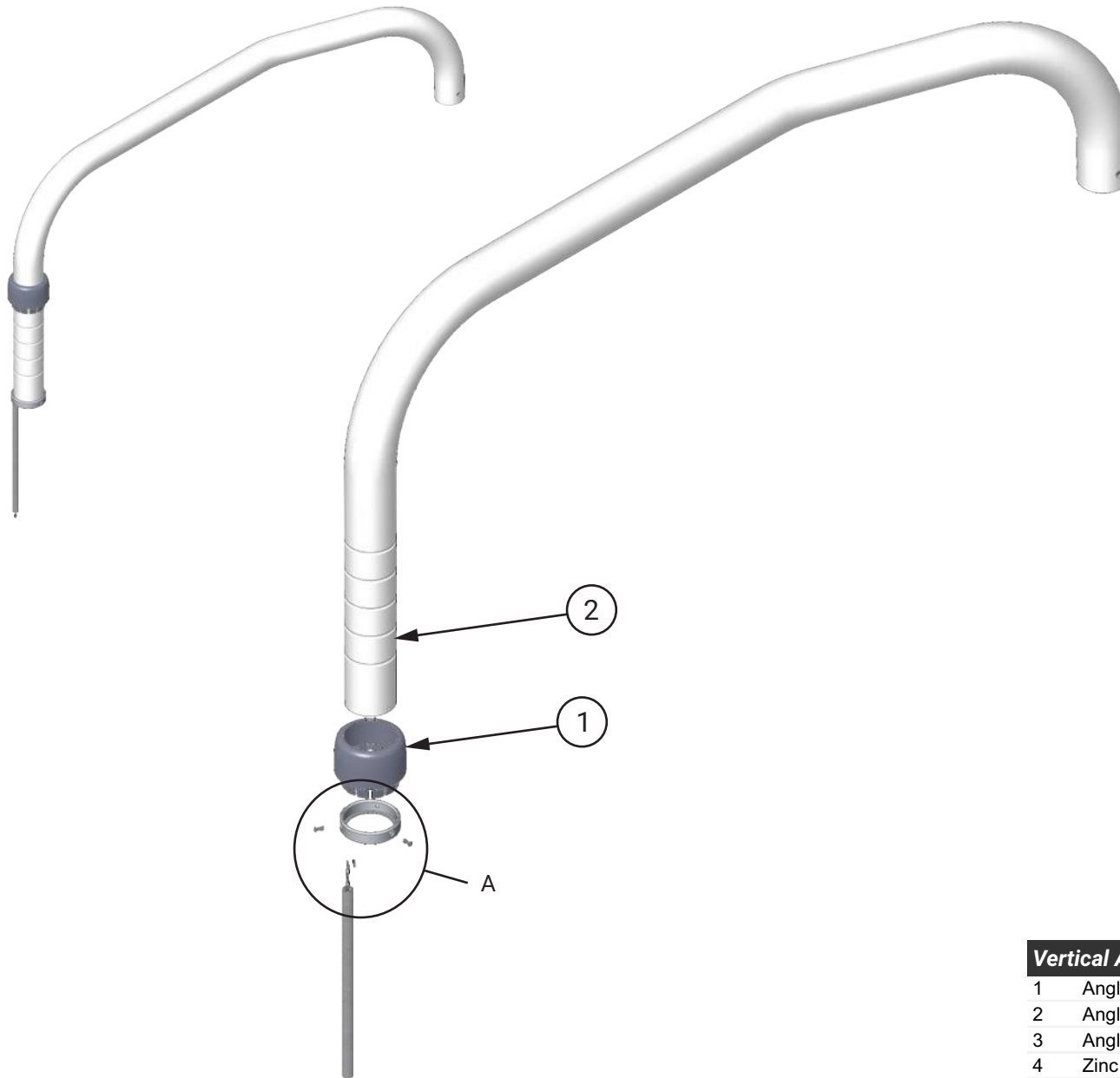

Detail A

Vertical Adjusted Angled Arm Sprint 19		972010021
1	Angled Arm Lock Clamp SP 19	8102800
2	Angled Arm Table MSA 19	9302799
3	Angled Arm Guide Ring MSA SP 19	8102752
4	Zinc Plated Chain Angled Arm	8003342
5	Gray PVC Hose Ø9 x 0.85 x 220mm	8102806

TABLE SUPPORT ARM - BI-ARTICULATED MECHANICAL

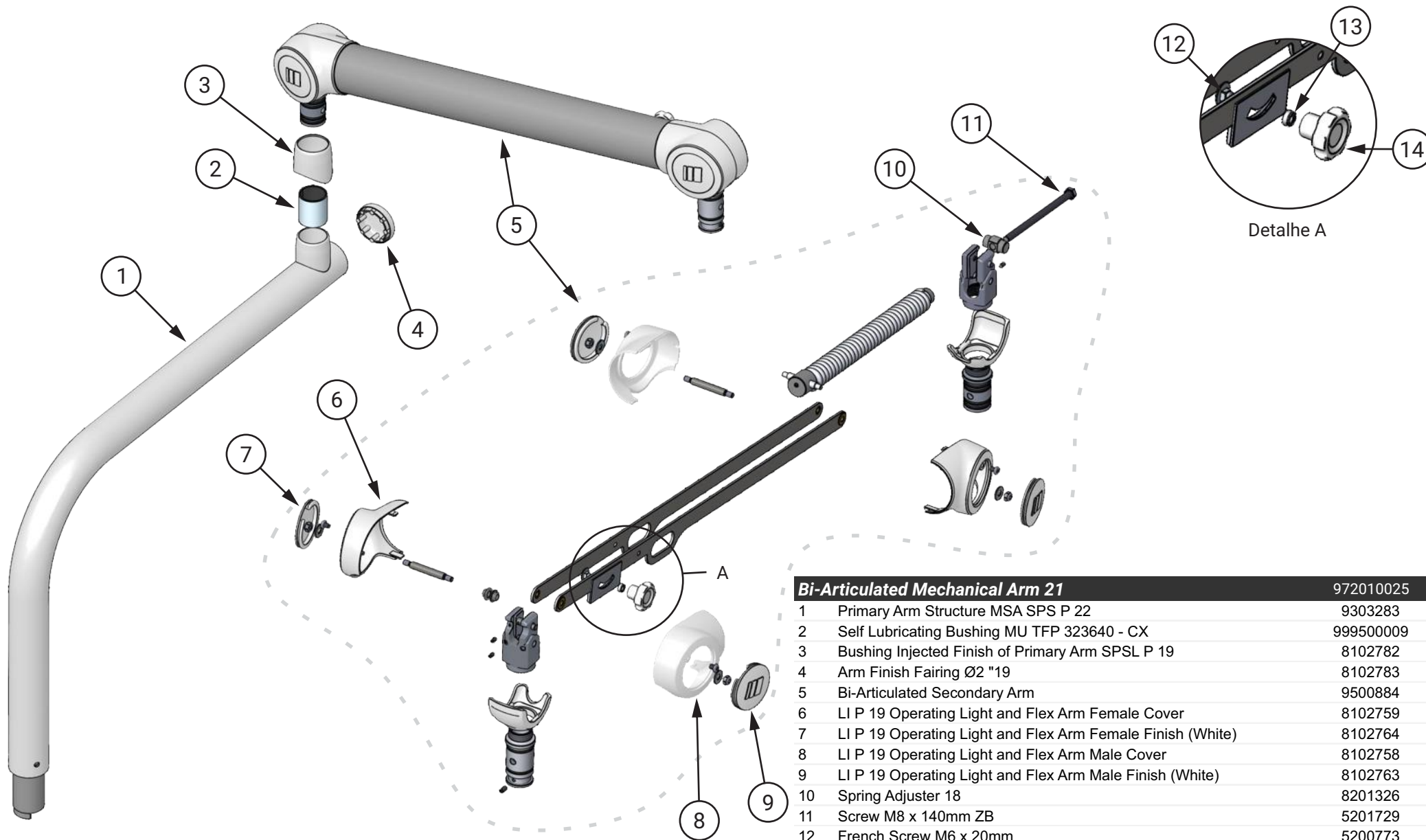

Bi-Articulated Mechanical Arm 21		972010025
1	Primary Arm Structure MSA SPS P 22	9303283
2	Self Lubricating Bushing MU TFP 323640 - CX	999500009
3	Bushing Injected Finish of Primary Arm SPSL P 19	8102782
4	Arm Finish Fairing Ø2 "19	8102783
5	Bi-Articulated Secondary Arm	9500884
6	LI P 19 Operating Light and Flex Arm Female Cover	8102759
7	LI P 19 Operating Light and Flex Arm Female Finish (White)	8102764
8	LI P 19 Operating Light and Flex Arm Male Cover	8102758
9	LI P 19 Operating Light and Flex Arm Male Finish (White)	8102763
10	Spring Adjuster 18	8201326
11	Screw M8 x 140mm ZB	5201729
12	French Screw M6 x 20mm	5200773
13	Screw Lockof the Bi-Articulated Arm Brake	8102903
14	CZ Handle	1700079

TABLE SUPPORT ARM - FLEX

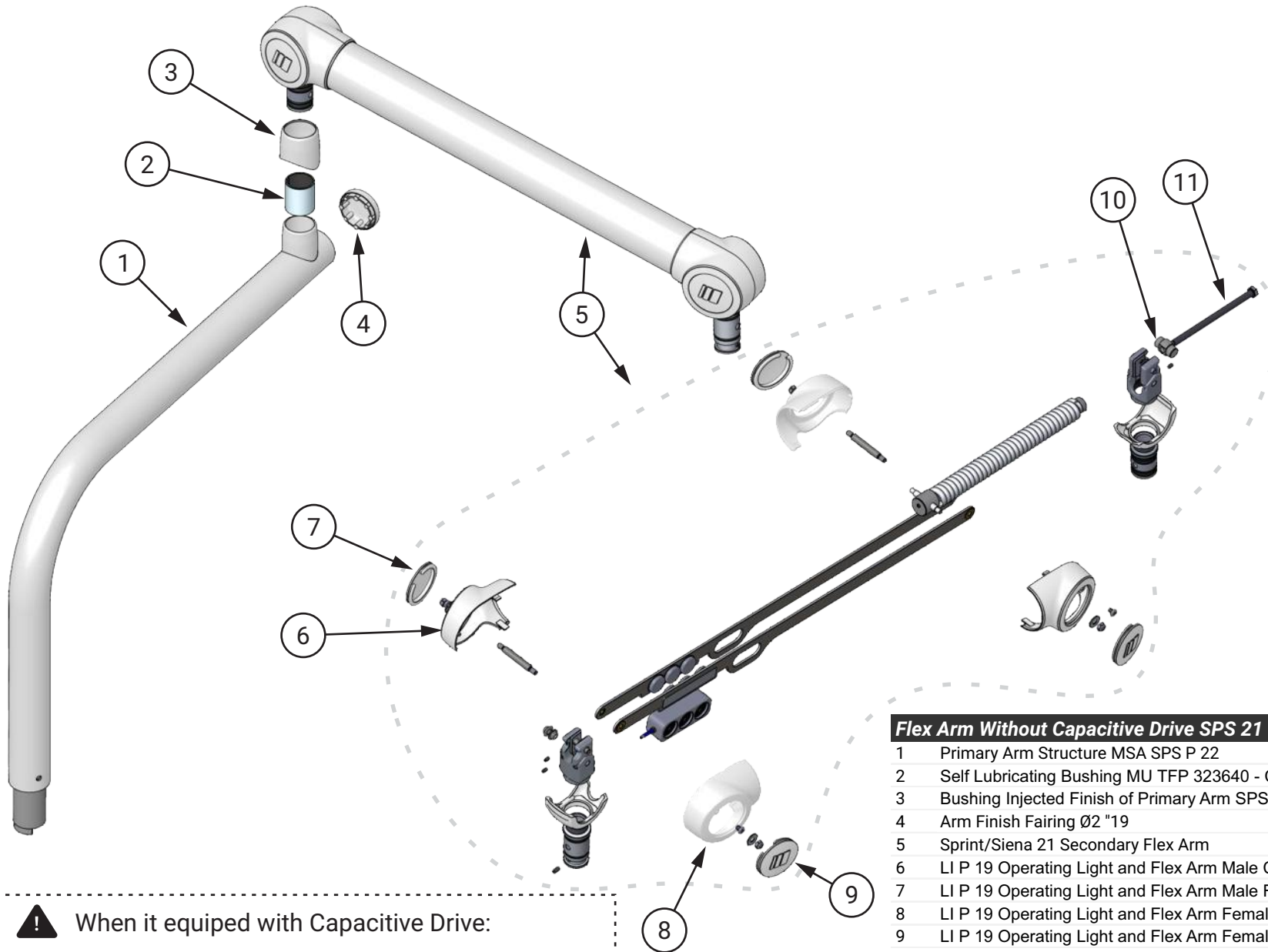

! When it equipped with Capacitive Drive:
Flex Arm With Capacitive Drive SPS 21 972010029

Flex Arm Without Capacitive Drive SPS 21		972010027
1	Primary Arm Structure MSA SPS P 22	9303283
2	Self Lubricating Bushing MU TFP 323640 - CX	999500009
3	Bushing Injected Finish of Primary Arm SPSL P 19	8102782
4	Arm Finish Fairing Ø2 "19	8102783
5	Sprint/Siena 21 Secondary Flex Arm	9500882
6	LI P 19 Operating Light and Flex Arm Male Cover	8102758
7	LI P 19 Operating Light and Flex Arm Male Finish (White)	8102763
8	LI P 19 Operating Light and Flex Arm Female Cover	8102759
9	LI P 19 Operating Light and Flex Arm Female Finish (White)	8102764
10	Spring Adjuster 18	8201326
11	Screw M8 x 140mm ZB	5201729

WORKING TABLE - PART I

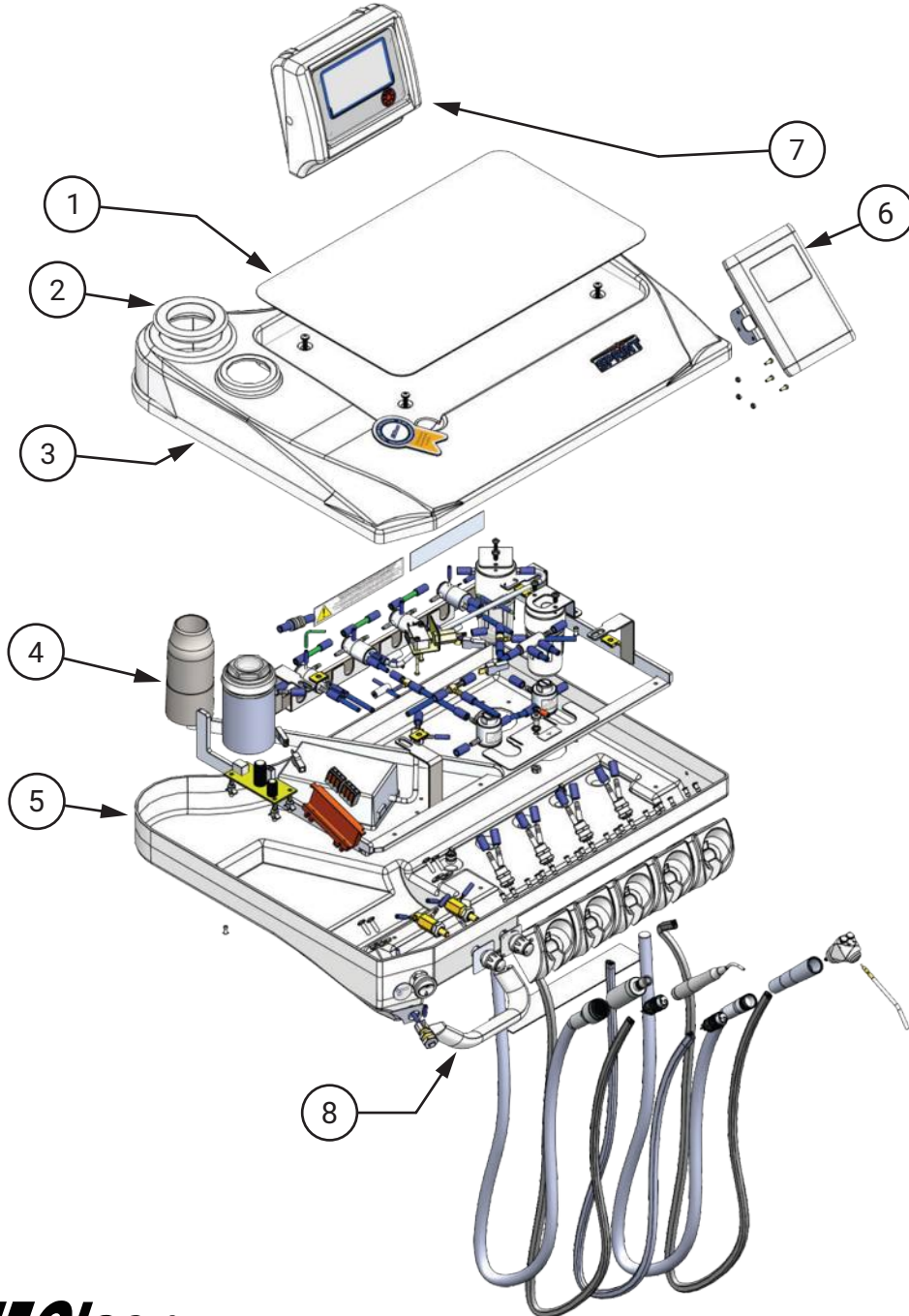

! Use the following codes when:

When the working table support arm is angled 972010021		
2	White Machined Finishing Flange	8101251
4	Structure MSA Angled Arm SP 20	9303014
When without prophylaxis		
3	MSA SP 20 Upper Cover without Prophylaxis	8102906

Sprint Working Table		MSA-SP 002
1	SP 20 Tray	8201362
2	White Injected Finishing Flange	8101578
3	MSA SP 20 Upper Cover with Prophylaxis	8102907
4	MSA SP 20 Structure	9303013
5	MSA SP 20 Lower Cover	8102908
6	Portable Brushless Micromotor 21	999500174
7	Coupled X-ray View LED	9400785
8	Table Handle	8102003

WORKING TABLE - PART II

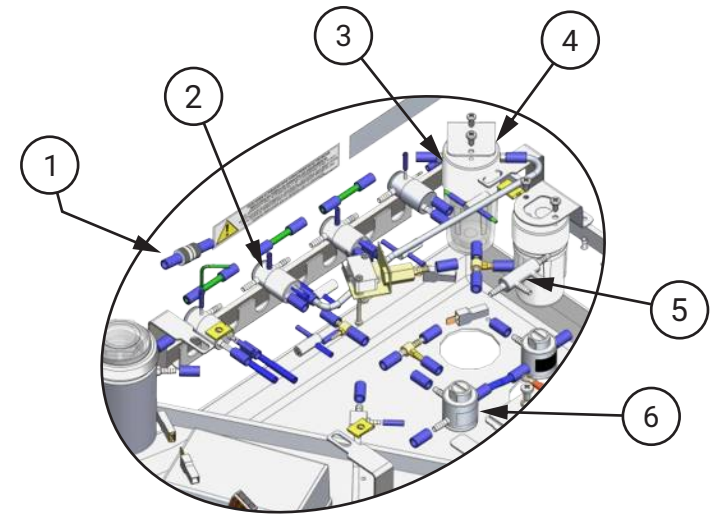
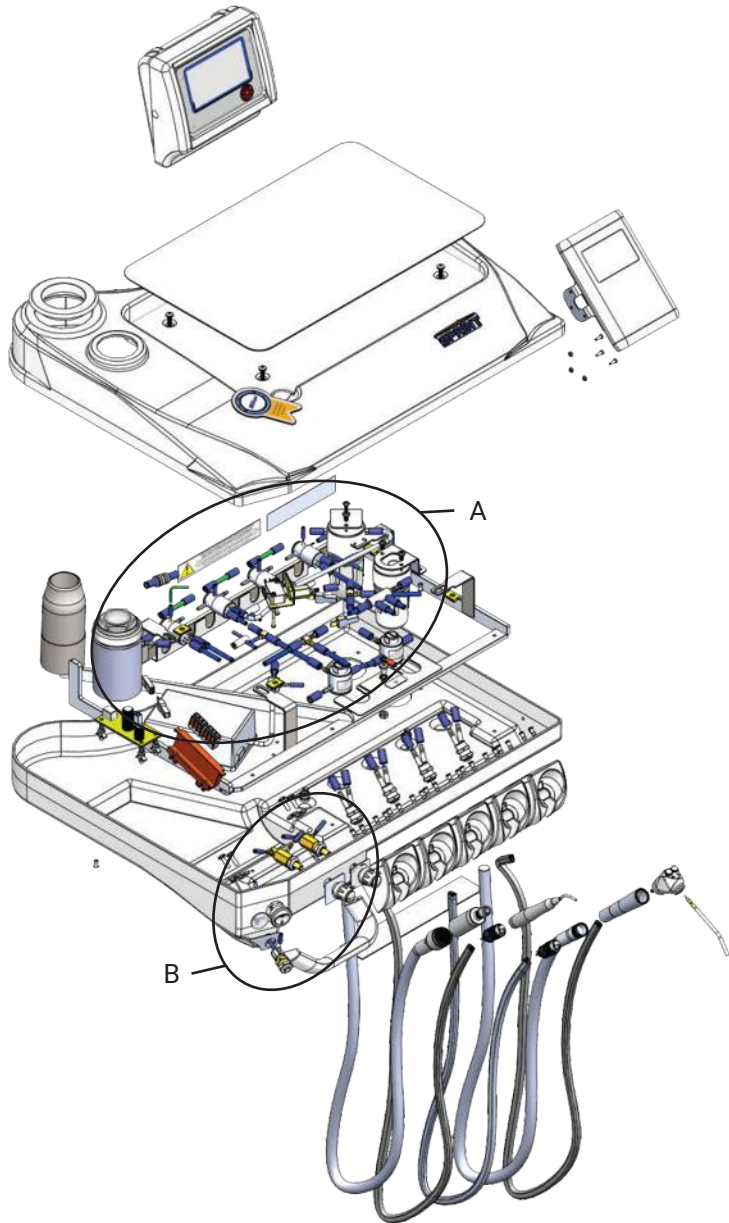

Detail A

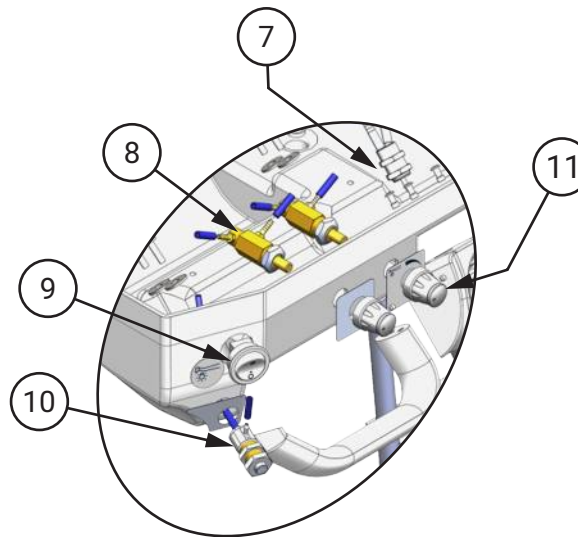

Detail B

Sprint Working Table		MSA-SP
1	Retention valve	7000185
2	Suction Valve 2008	3100171
3	Prophylaxis Filter 20	9303124
4	Filter Holder Prophylaxis Siena Tray	8002005
5	4 Way Multiple Flow Adjustable Valve	3100140
6	Reduction Valve	3100121
7	Support Valve	3200121
8	Logic Table / Scaler Water Regulator Valve	9401118
9	Round Key Switch	2200860
10	Flex Arm Brake Button	9301344
11	Water Valve Button	8201160

INSTRUMENTS AND THEIR COMPONENTS - PART I

Vacuum Pump Ejector

1	Sleeve for Ejector - ODO - 22	8201415
2	Ejector Valve 22	8201416
3	Plastic Part for Strong Ejector Valve	999500180
4	Vacuum Pump Ejector Adapter	999500232
5	Sewer Cap	8102818
6	Double Spike	8200895
7	Union Terminal	8201272
8	Vacuum Pump Adapter 1 Ejector	9301466
9	Vacuum Pump Adapter 2 Ejectors	9301467
10	Scaler and Vacuum Pump Instrument Holder	9401291

Venturi Ejector

1	Venturi Suction Connector	9301670
2	Venturi Suction Connector (High Power)	9301669
3	Ejector Canula Connector Ø6,3mm	8101776
4	Ejector Canula Connector Ø9,5mm	8101775
5	Instrument Holder with Reed	9302573
6	Double Spike	8200895
7	Venturi 18 Suction Set	9401334
8	Air Valve Click	9302478
9	Tip Support Valve	3200121
10	Venturi Suction Filter Cover	8102854
11	Oring	3100221
12	Filter Body	8100001
13	Venturi Suction Filter Cover	8102778
14	Venturi Suction Filter	9300339

Vórtice Ejector

1	Vórtice Ejector Instrument Holder	8102992
2	Vórtice Drive 21	9303159
3	Ejector Female Body	8201232
4	Ejector Male Body	8201233
5	Ejector Canula Connector	8101775
6	Pneumatic Vórtice Ejector Kit	9500885
7	1 x 3 Way Distributor	9300111
8	HVE post	8201229
9	Vórtice Ejector Suction Set 18	9401335
10	3 Way Distributor - 3/16 "	9302704
11	Injected Vórtice Ejector Filter Cover 19	8102855
12	Oring ring	3100221
13	Filter Body	8100001
14	Injected Vórtice Suction Filter Cover 19	8102779
15	Vórtice Suction Filter	9302298

Sewer Connector

1	Sewer Connector Cover 18	8102645
2	Oring	3100220
3	Sewer Connector Body 18	8102647

INSTRUMENTS AND THEIR COMPONENTS - PART II

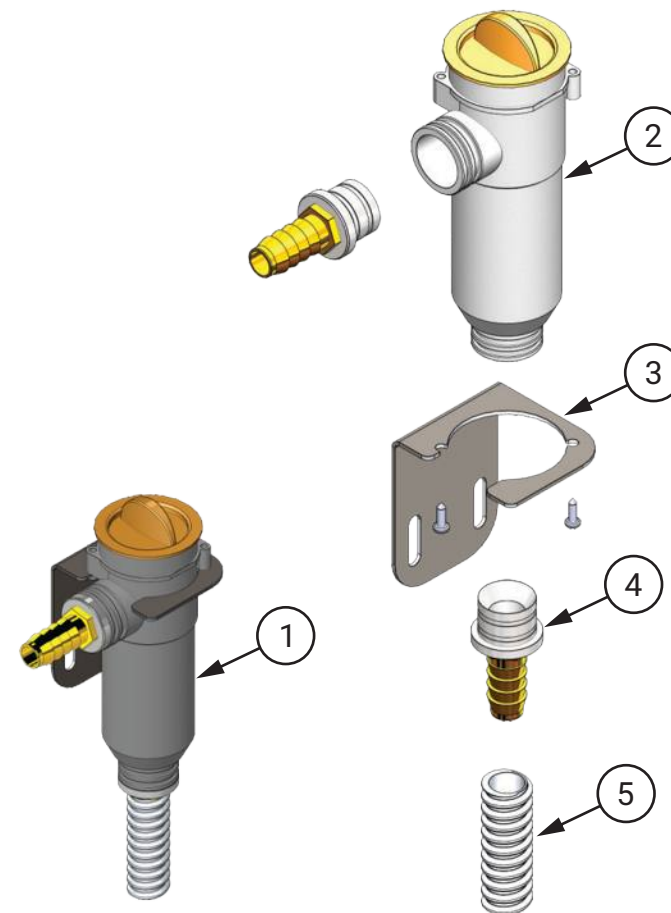
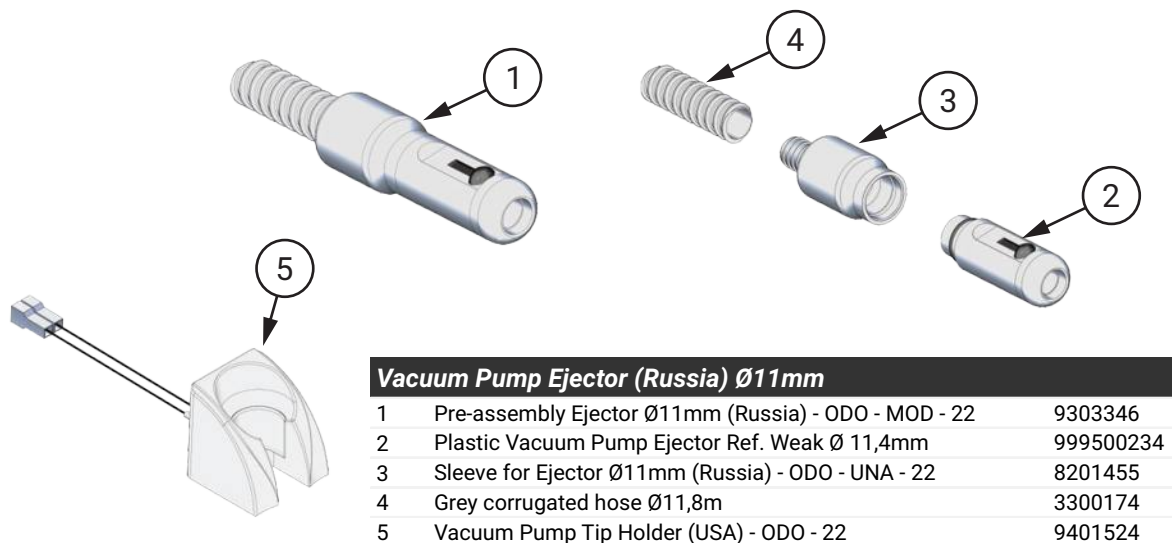
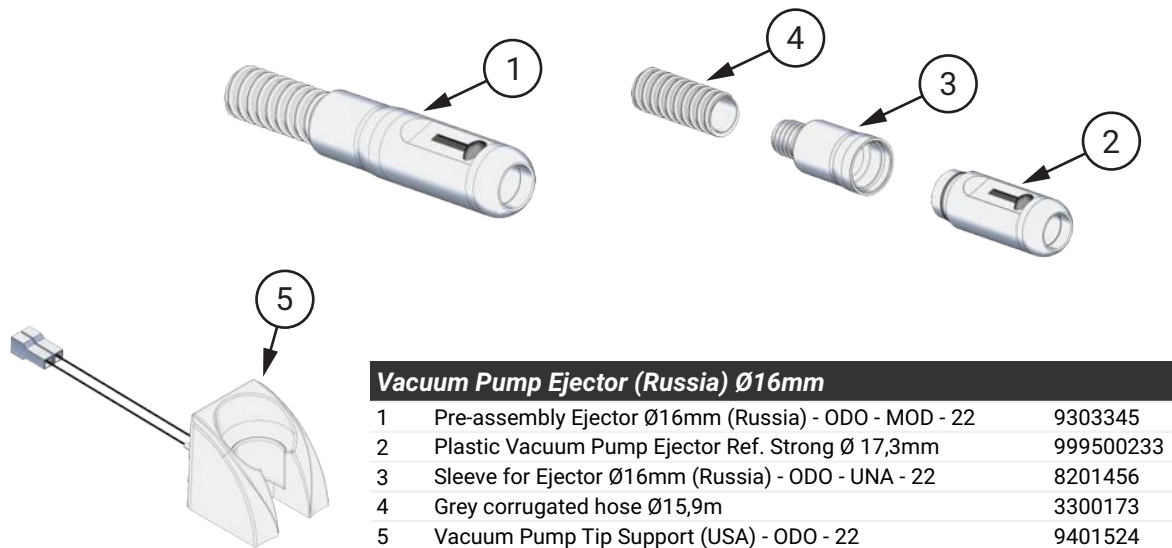

INSTRUMENTS AND THEIR COMPONENTS - PART III

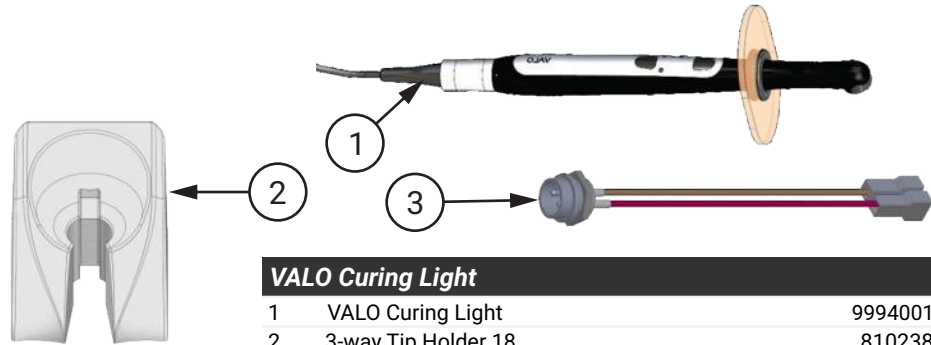

VALO Curing Light

1	VALO Curing Light	999400121
2	3-way Tip Holder 18	8102383
3	Preassembled Connector	9301477

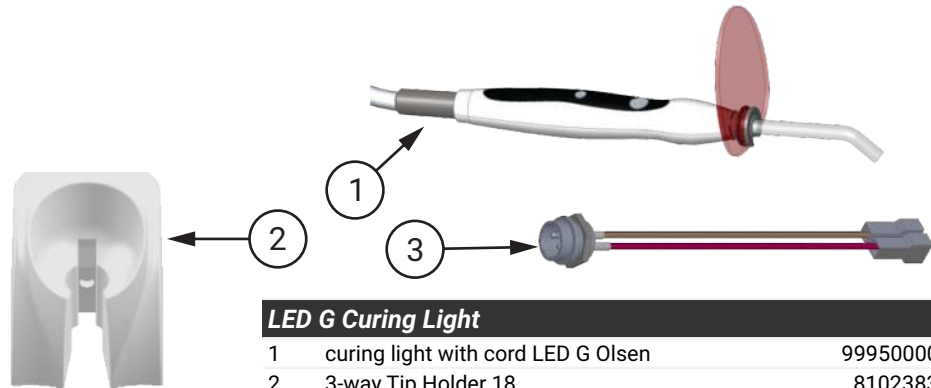

LED G Curing Light

1	curing light with cord LED G Olsen	999500006
2	3-way Tip Holder 18	8102383
3	Preassembled Connector	9301477

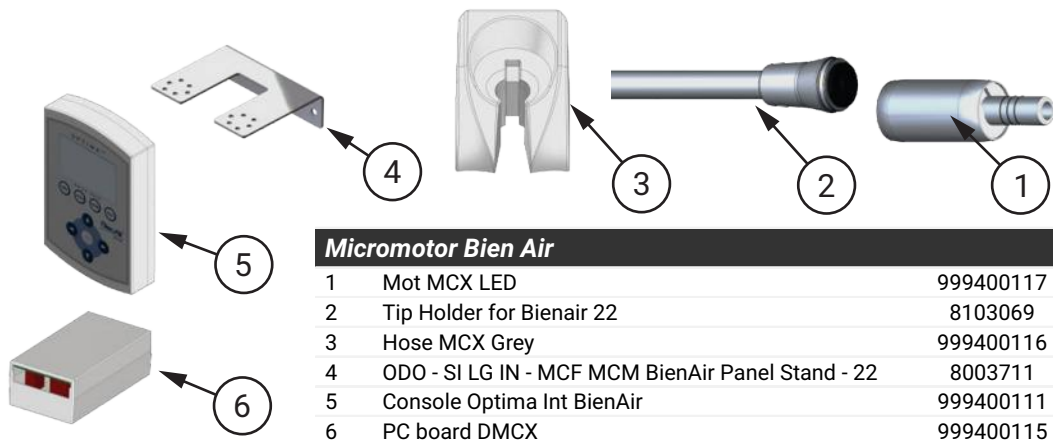

Micromotor Bien Air

1	Mot MCX LED	999400117
2	Tip Holder for Bienair 22	8103069
3	Hose MCX Grey	999400116
4	ODO - SI LG IN - MCF MCM BienAir Panel Stand - 22	8003711
5	Console Optima Int BienAir	999400111
6	PC board DMCX	999400115

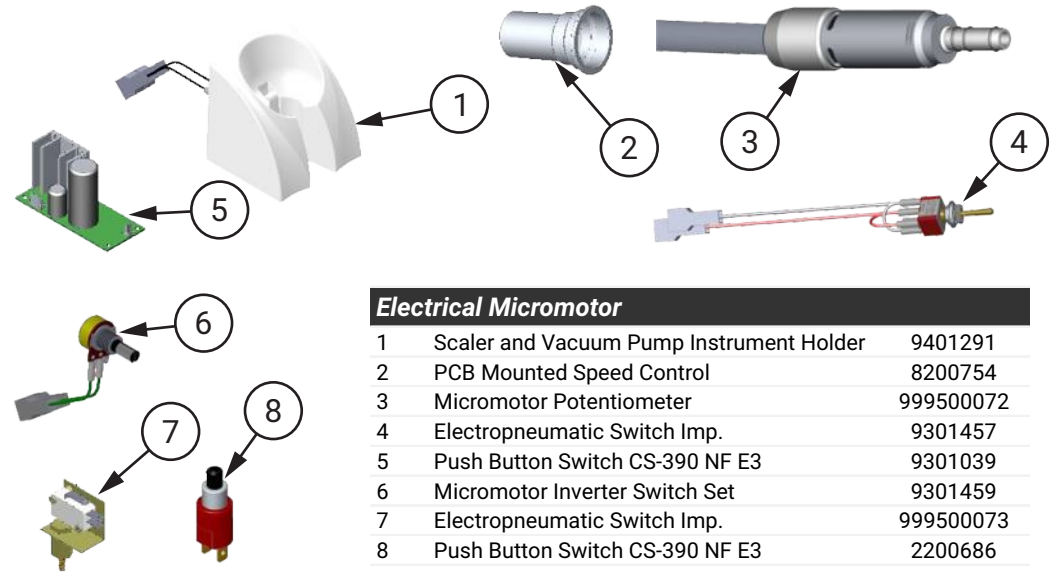

Electrical Micromotor

1	Scaler and Vacuum Pump Instrument Holder	9401291
2	PCB Mounted Speed Control	8200754
3	Micromotor Potentiometer	999500072
4	Electropneumatic Switch Imp.	9301457
5	Push Button Switch CS-390 NF E3	9301039
6	Micromotor Inverter Switch Set	9301459
7	Electropneumatic Switch Imp.	999500073
8	Push Button Switch CS-390 NF E3	2200686

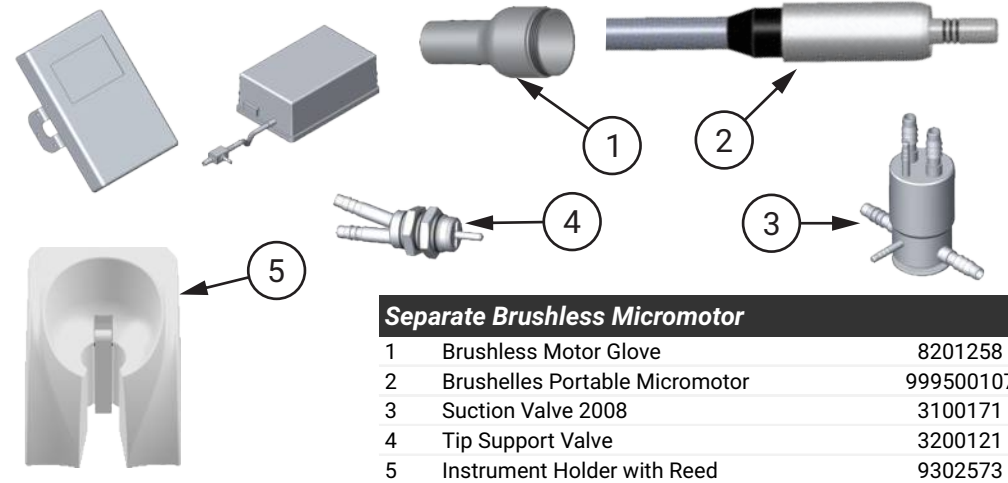

Separate Brushless Micromotor

1	Brushless Motor Glove	8201258
2	Brushelles Portable Micromotor	999500107
3	Suction Valve 2008	3100171
4	Tip Support Valve	3200121
5	Instrument Holder with Reed	9302573

INSTRUMENTS AND THEIR COMPONENTS - PART VI

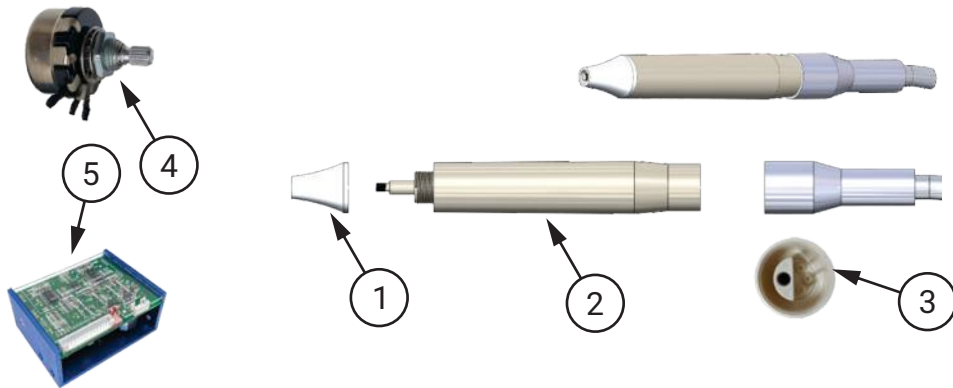

Scaler without LED

1	Finishing Tip (Hand Piece For V2 Led)	999500129
2	Main Body V2 (Handi piece For V2)	999500127
3	Plastic water passage pipe (Water Pipe For V2)	999500126
4	Potentiometer for V2 (Power Wrench For V2)	9303008
5	Olsen Scaler V2 LED Electronic Board	999500111

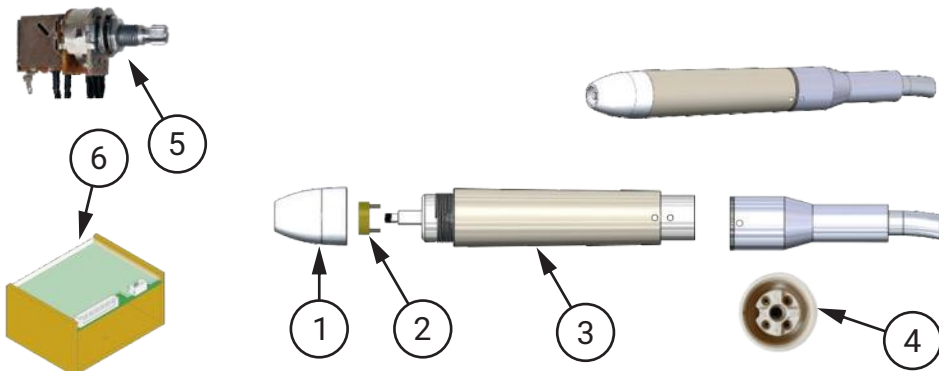

Scaler with LED

1	Finishing Tip (Hand Piece For V3 Led)	999500026
2	Main Body LED - Woodpecker Scaler Transducer	999500135
3	Main Body (Hand Piece For V3 Led)	999500021
4	Plastic Pipe for Water Passage (Water Pipe For V3 and V2)	999500020
5	Scaler Pot	9302153
6	Printed Circuit with Led (PCB For V3 Led)	999500025

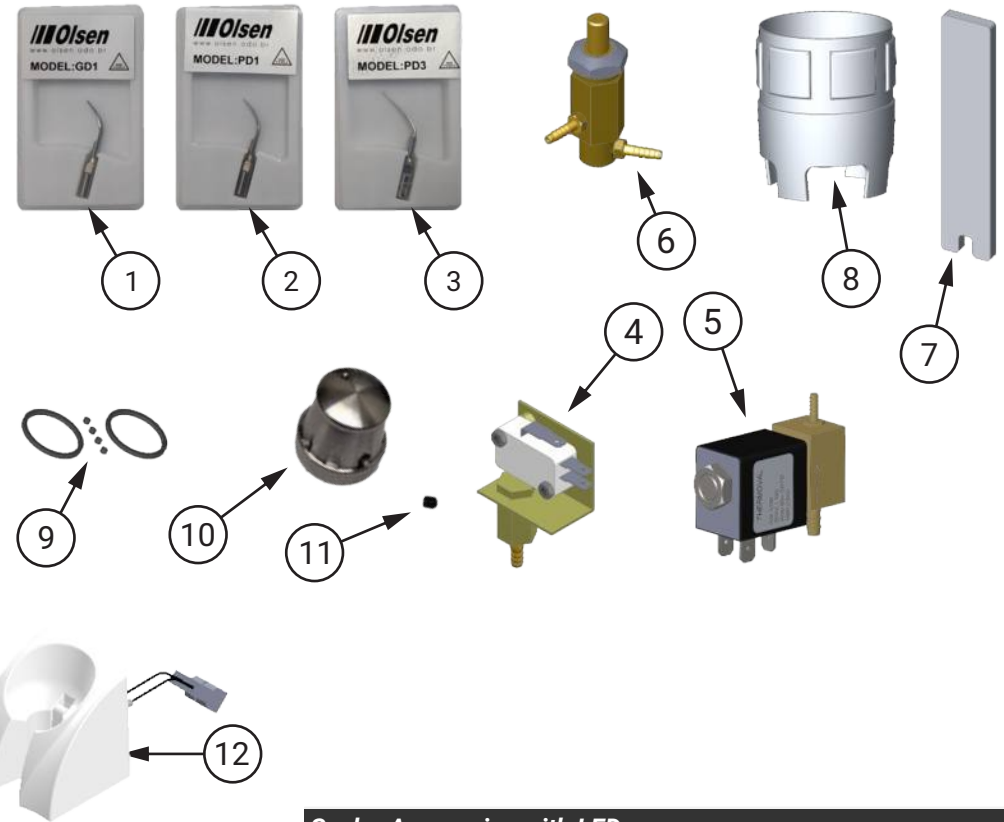

Scaler Accessories with LED

1	Tip for Piezo TIP GD1 - (US1)	999400009
2	PD1 Chiseling Tip for Piezo Light	999400013
3	PD3 Chiseling Tip for Piezo Light	999400024
4	Electro-Pneumatic Switch Imp.	999500073
5	Solenoid Valve 10W 32Vdc - Thermoval (12,100)	3100212
6	Ultrasonic Water Regulator Record / Logic Table	9401118
7	Nut Tight Hand Tool (Endo Wrench For V3 Led)	999500022
8	Screw Grip Hand Tool (Torque Wrench For V3 Led)	999500097
9	V3 Led Repair Kit	999500027
10	Water Adjustment Valve Button	8201160
11	Hexagon screw	5200729
12	Scaler and Vacuum Pump Instrument Holder	9401291

INSTRUMENTS AND THEIR COMPONENTS - PART V

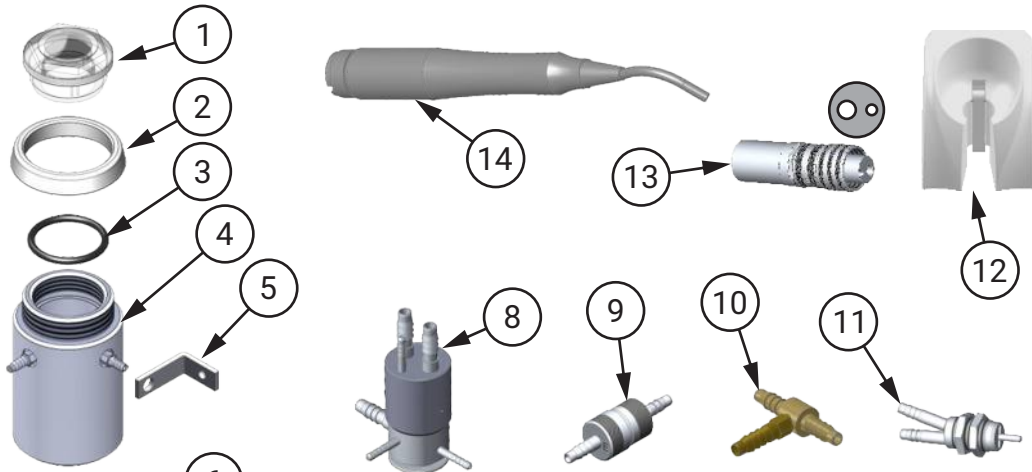

Prophylaxis Kit		9500552
1	Prophylaxis Cover / Oil Visor	1600278
2	Tank Support Prophylaxis	8200858
3	Prophylaxis Cover Ring	3100194
4	Powder Cup Level	8101387
5	Support for Reservoir Prophylaxis	8001605
6	Tank with Adhesive Siena / Sprint	9302295
7	Prophylaxis Filter 20	9303124
8	Suction Valve	3100172
9	Retention Valve	7000185
10	3 Way Distributor - 3/16 "	9302704
11	Tip Support Valve	3200121
12	Instrument Holder with Reed	9302573
13	Borden Terminal with Refrigeration	7000122
14	Olsen Prophylaxis Pen	7000334



Prophy-Jet 999500042

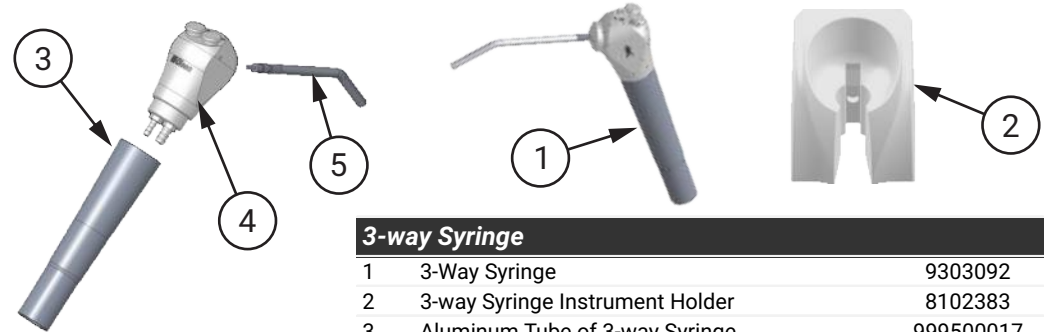

3-way Syringe		
1	3-Way Syringe	9303092
2	3-way Syringe Instrument Holder	8102383
3	Aluminum Tube of 3-way Syringe	999500017
4	Hydropneumatic Metal Valve	999500019
5	Hydropneumatic Metal Tube	999500018

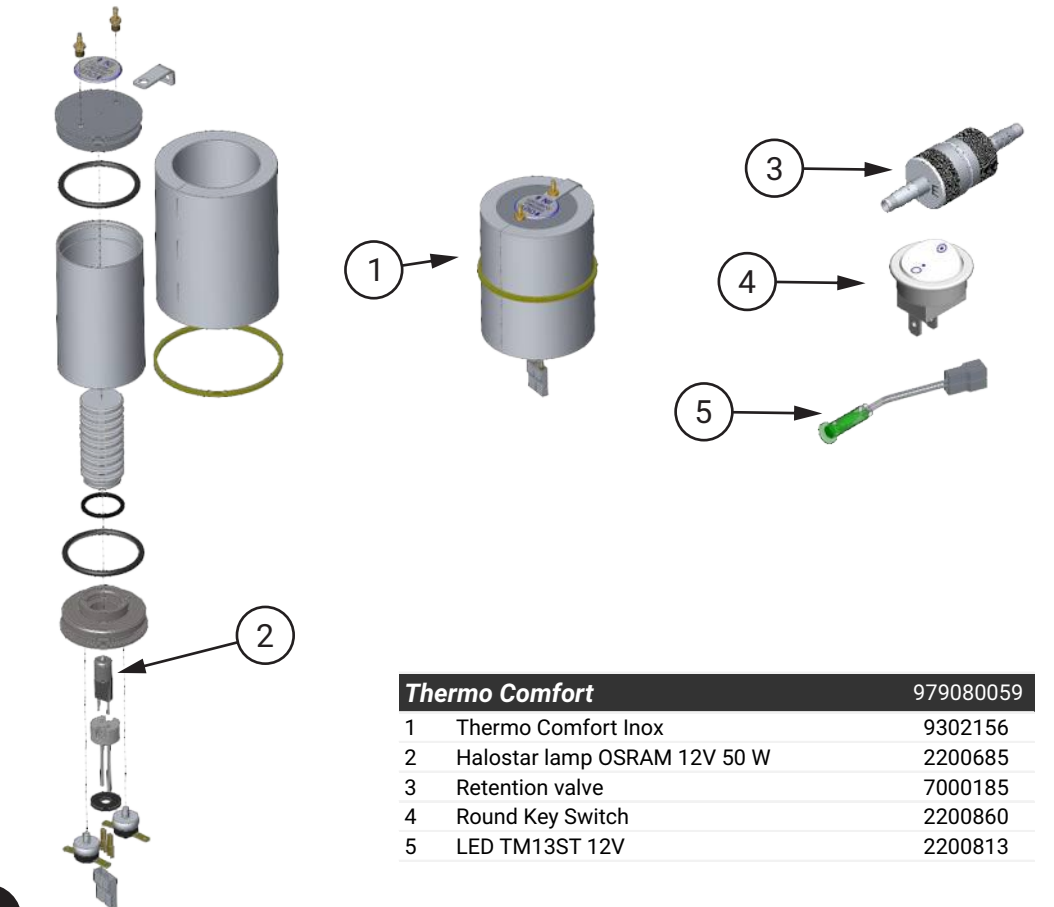

Thermo Comfort		979080059
1	Thermo Comfort Inox	9302156
2	Halostar lamp OSRAM 12V 50 W	2200685
3	Retention valve	7000185
4	Round Key Switch	2200860
5	LED TM13ST 12V	2200813

INSTRUMENTS HOLDER

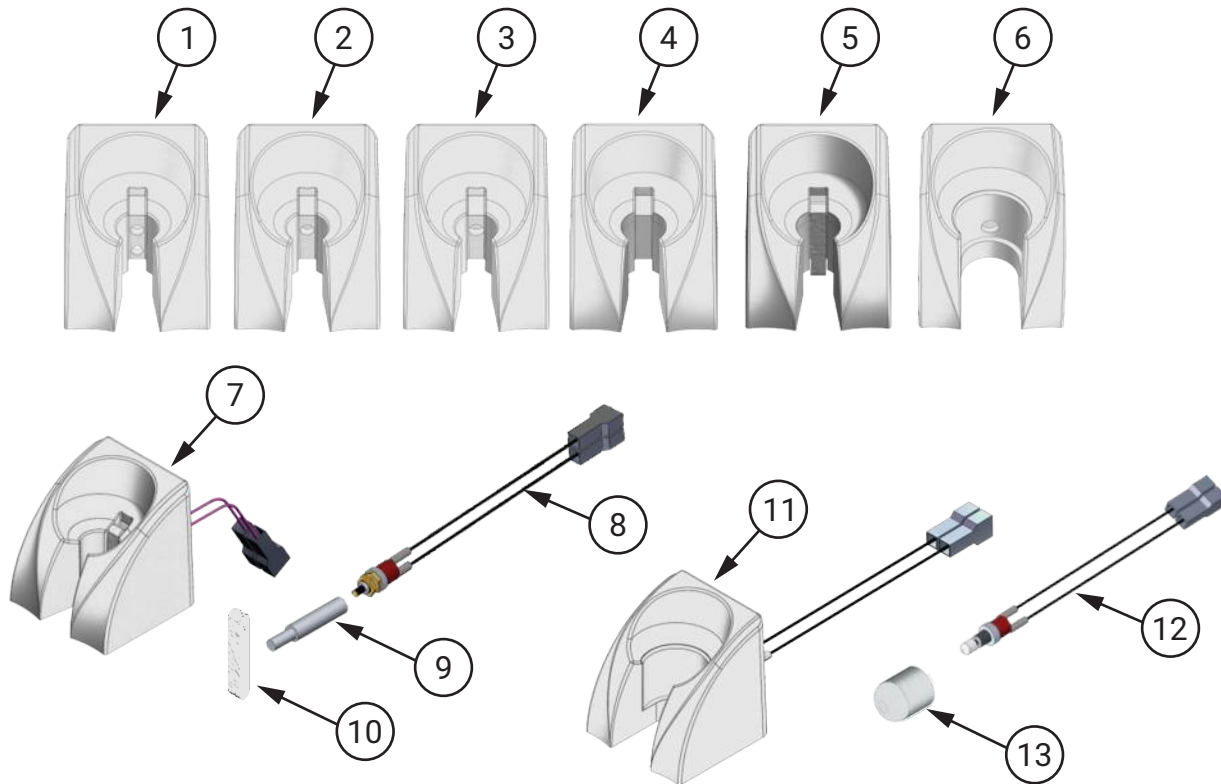

Suportes de Instrumentos

1	Tip Holder for Air Jet 18	8102514
2	Tip Holder 18	8102516
3	Tip Holder 18 with thread 1-4 for Scaler and Vacuum Pump	8102997
4	Bienair Tip Holder 22	8103069
5	Bienair Tip Holder with Reed 22	9303280
6	Vacuum Pump Tip Holder (USA) - ODO - 22	8103093
7	Tip Holder for Micro Motor 18	9401292
8	Micro Switch for Scaler and Vacuum Pump	9300612
9	Air Jet Drive Pin	8101605
10	Reed for Tip Holder	8100106
11	Vacuum Pump Micro switch (USA) - ODO - 22	9401524
12	Vacuum Pump Tip Support (USA) - (ODO - 22)	9303304
13	Vacuum Pump Support Button (USA) - ODO - 22	8103094

COUPLING TERMINALS

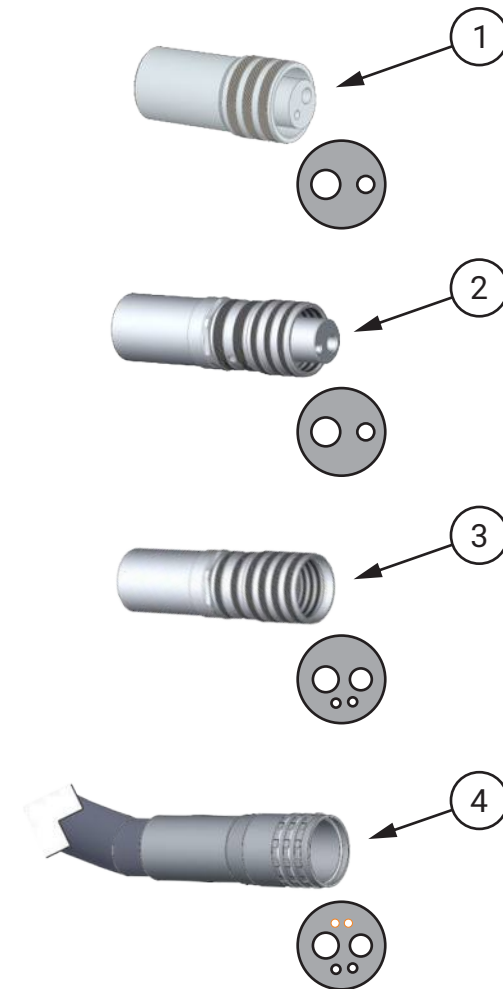

Coupling Terminals for Instruments

1	Borden Terminal without Refrigeration	7000121
2	Borden Terminal with Refrigeration	7000122
3	Midwest Terminal	7000159
4	Midwest Fiber Optics Set	999500069

INTRODUCTION TO THE PARTS PRESENTED IN THIS SECTION

› **Parts**

Hoses	35
Electrical Components	36
Valves and Connections - Part I	37
Valves and Connections - Part II	38

The tables below show the main hoses of the equipment.

Air Hoses



Description	Code	Application
PU Blue Hose Ø 4,76 x 2mm	3300004	Main Air Entrance
PU Blue Hose Ø 3,2 x 1mm	3300159	Internal Distribution
PU Blue Hose Ø 3,2 x 0,5mm	3300161	Midwest Coupling
PU Blue Hose Ø 1,6 x 0,8mm	3300122	Flex Arm Brake
PU Blue Hose Ø 2,5 x 0,75mm	3300144	HVE
PU Blue Hose Ø 1,5 x 0,5mm	3300162	Midwest Coupling

Water Hoses



Description	Code	Application
Green PU Hose Ø 5,7 x 2mm	3300104	Main Water Entrance
Green PU Hose Ø 3,2 x 1mm	3300160	Internal Distribution
Green PU Hose Ø 1,5 x 0,5mm	3300163	Midwest Coupling

PVC Grey Hoses



Description	Code	Application
Gray Flexible Hose Ø 15.9 x 2mm	3300115	Pedal
PVC Grey Hose Ø 9 x 0,85mm	3300164	Midwest Coupling
Malleable Gray Hose Ø 6.3 x 1mm	3300001	Operating Light
PVC Grey Hose Ø 8 x 1,5mm	3300002	Vacuum Pump
PVC Grey Hose Ø 5,7 x 1,5mm	3300149	Venturi Ejector

Cristal Hoses



Description	Code	Application
Cable gland Ø 20mm	2200680	Flex Arm
Cristal Hose Ø 6,3 x 2mm	3300109	Sewer Cupfiller / Ejectors
Cristal Hose Ø 3,2 x 0,5mm	3300165	Midwest Coupling
Cristal Hose Ø 12,7 x 2mm	3300112	Midwest Filter

Corrugated Hoses



Description	Code	Application
Corrugated Hose Ø 31,7mm	3300117	Delivery Unit / Water Unit
Gray Corrugated Hose Ø 38.1mm	3300146	Junction Box
Corrugated Grey Hose Ø 19mm	3300147	S. Bowl Sewer / Steady Arm
Corrugated Beige Hose Ø 12,7mm	3300131	HVE and sewage dewatering (USA and Russia)
Corrugated Grey Hose Ø 11,8mm	3300174	Vacuum Pump Sucker (Russia)
Corrugated Grey Hose Ø 15,9mm	3300173	Vacuum Pump Sucker (Russia)

Special Hoses



Description	Code	Application
Double Grey Hose for Pedal	3300123	Propulsion Pedal
Triple Pedal Hose Gray L.	3300124	Double Pedal
3-way Grey Hose	3300142	Borden Coupling
4-way Hose (Midwest)	3300151	Midwest Coupling Olde Model

Below is a list with the drawings, codes and description of the Electrical Components





















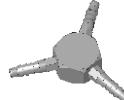













	2200371 Micro Switch PushButton 0.5 INF		2200396 Emergency Switch		2200914 SMC Transformer 124.2VA 0 / 118V / 127V / 220V / 230V 0.6KV 50 / 60HZ		9302557 Electric Drive Pedal
	2200186 Microswitch MG-2608 IR / E3G 20A		2200804 LED for Operating Light Olsen - Cree XLamp XM- L2 Leds		9300612 Vacuum Pump Micro Switch		999500025 Printed Circuit with Led (PCB For V3 Led)
	2200373 Inverter Micro Switch		2200813 LED TM13ST 12V LED		9301039 PCB Mounted Speed Control		999500111 Olsen Scaler V2 LED PC Board
	999500185 ON/OFF Switch		2200840 Board for Cup Holder / Spittoon Bowl Siena/Quality		9301457 Micromotor Inverter Switch Set		2200277 Micro Switch BR15IL - QACS
	2200767 Touch Sensor 24VAC (Olsen)		2200848 Pushbutton switch CS-392 NA / E1BB 0.5A		9301459 Micromotor Potentiometer		2200194 Micro Switch BR15IL - QAAA
	2200918 LI Dental CPU Board with Integrated LED Drive		2200857 X-ray Board with Coupling for Touch 24Vac		9301460 Micromotor Micro Switch		2200902 12V 2.5A 100-220V Power Supply Massager Kit
	2200796 Fiber Optics Convert Board 24 / 3.3 AC / DC		2200860 Round Key Switch		9302153 Scaler Potentiometer		2200911 MBTBW1 Rectangular Fuse Holder White
	2200798 Capacitive Touch Board Table Logic		2200909 SPS Dental CPU Board with Integrated LED Operating Light Drive (without Touch)		9302156 Thermo Comfort Inox		

VALVES AND CONNECTIONS - PART I

Below is a list with the drawings, codes and description of the Valves and Connections.

	3100121 Reduction Valve		3100213 Solenoid Valve 32Vdc 10W - Thermoal (21,711)		8201232 Ejector Female Body		9301866 Distributor Thermo Comfort Syringe / Scaler
	3100136 Water Valve (Button)		3200113 Spray Flow Adjustable Valve		8201233 Ejector Male Body		9302156 Thermo Comfort Inox
	3100140 4 Way Multiple Flow Adjustable Valve		3200121 Tip Support Valve		9300111 1 x 3 Way Distributor		9302256 3 Way Distributor - 3/16 "x 3/16" x 3/32 "
	3100159 3 Way Multiple Flow Adjustable Valve		7000121 Sleeve and Terminal for Micromotor		9300137 1 x 2 Way Distributor		9302478 Air Valve Click
	3100171 Suction Valve 2008		7000122 3-way hose for High Speed		9301344 Brake Pushbutton for Flex Arm Single Tray		9302704 3 Way Distributor - 3/16 "
	3100172 Suction Valve 2008 with Terminal		7000185 Retention valve		9303124 Prophylaxis Filter 20		9303053 Filter for Midwest and Fiber Optics
	3100211 Solenoid Valve 32Vdc 10W (21710) w / Muffler for Capacitive System		7000334 Olsen Prophylaxis Pen (Meditec)		9301669 Venturi Ejector Connector (High Power)		9400077 Complete Water Valve
	3100212 Solenoid Valve 32Vdc 10W - Thermoal (12,100)		8101775 Cannula Ejector Connector Ø 9.5mm		9301670 Venturi Ejector Connector		9400635 Logic Progressive Valve

VALVES AND CONNECTIONS - PART II

	9400672 Olsen Vacuum Ejector		999500017 Aluminum Tube Ø 16 x 82 mm (for Syringe)		7000185 Retention valve		999500232 Vacuum Pump Sucker Adapter
	9400706 Pressurizer Kit for Bicarbonate		999500018 Hydropneumatic Metal Tube (for Syringe)		8201043 Connection Ø 4 x 20mm		8201436 Union 7.94 X 6.4 x 30,5mm Stainless Steel
	9401020 Water Unit Inlet Valve		999500019 Hydropneumatic Metal Valve (for Syringe)		9301147 1 x 3 Way Distributor Ø 3/16		8201443 Water Connector (USA) - ODO - 22
	9401118 Scaler Water Adjustment Valve / Logic Table		999500020 Plastic Pipe for Water Passage (Water Pipe For V3 and V2)		9400557 Long Water Valve Complete		8201445 Spigot Ø2,9 x 15,8mm Stainless steel
	9401202 Tank Filter Kit Siena / Sprint		8101776 Cannula Suction Connector		9401021 Olsen Progressive Actuation Valve		8201446 Union Lug Ø4,76
	9401247 Valve Adjustment for Fiber Optics		999500069 Fiber Optics Hose Assembly Imp.		9401369 SPSLI 18 Scaler Connection Set		8201448 Threaded spigot stainless steel
	9401334 Ejector Set Venturi 18		999500073 Electro-Pneumatic Switch Imp.		999500070 Air Regulator with Imp Filter..		8201449 3-Way Manifold Body Ø3-16 Stainless Steel
	9401335 Ejector Set Vórtice 18		3100143 Pneumatic Brake Valve		3100162 Tank Water Filter		9303303 Stainless Steel Tank Cover Connection - ODO - 22
			3100224 24Vdc Solenoid Valve		3100225 Double Solenoid Valve 24Vcc		9303344 Ejector T Connection Set (RUSSIA) - ODO - 22













































INTRODUCTION TO THE PARTS PRESENTED IN THIS SECTION

› **Information**

Tools	40
Instructions	41
Troubleshooting Table - Part I	42
Troubleshooting Table - Part II	43
Troubleshooting Table - Part III	44
Troubleshooting Table - Part IV	45
Troubleshooting Table - Part V	46
Troubleshooting Table - Part VI	47
Troubleshooting Table - Part VII	48
Revisions Program	49
Features - Chair	50
Features - Accessories	51
Sprint T- Side View	52
Sprint T- Upper View	53
Sprint - Side View	54
Sprint - Upper View	55
Diagrams	56

TOOL LIST

Below is the list of recommended tools to installation and maintenance Olsen Medical and Dental Units.

 Universal Plier with Electrical Insulation	 Cutting Plier with Electrical Insulation	 Long Nose Plier with Electrical Insulation	 Retaining Rings Plier	 Jaw Plier
 Riveter	 Flat Blade Screw Driver: 1/8 x 2" - 1/8 x 4" - 1/4 x 6" - 3/8 x 10" - 3/16 x 4"	 Philips Screwdriver: 3/16 x 4" - 3/16 x 6"	 Short Handle Flat Blade Screwdriver: 1/4" x 1.1/2"	 Short Handle Philips: 1/4" x 1.1/2"
 L Wrench: 10 x 10 e 11 x 11mm	 L Wrench with Hole 11 x 11mm	 Open End Wrenches: from 6mm to 23mm	 Combination Wrenches Set: from 6mm to 24mm	 Adjustable Wrench
 Chaves Allen Curta: 1,5 - 2,0 - 2,5 - 3,0 - 4,0 - 5,0 - 6,0 - 7,0 - 8,0 - 9,0 - 10,0mm	 Long Hex Keys: 1,5 - 2,0 - 2,5 - 3,0mm	 Bal Point Hex Keys: 5 and 6mm	 T Handle Ball Pointed Hex Key: 2,5 and 3 mm	 Nail Remover Screwdriver 7.3/8"
 Cabinet Rasp 9"	 Cabinet File, Smooth Cut 8"	 Hammer	 Nylon's Hammer	 Measuring Tape 3 meters
 Hammer Drill 1" - 550 Watts	 Hole Saw Set for Wood	 Concrete Drill Set from 4,00 to 10mm	 Steel Drill Set from 1,0 to 13,0 mm	 Extension Cord 3 meters
 Magnetic Level	 Hacksaw	 Small Cutter	 Universal Scissors	 Insulated Tweezer with Narrow Tip
 Testing Screwdriver	 Digital Multimeter	 Soldering Iron 70 Watts	 Manometer 0 to 6 BAR for Borden Coupling	 Manometer 0 to 6 BAR fo Midwest Coupling
 Caliper Rule 150mm	 Tool Center 18 Irwin	 Tool Case	 Cart for Boxes	

PRE-INSTALLATION

- › **Compressed Air:** Dental compressor should form the basic technical characteristics, pressure between 5.5 and 7.0 (80 to 100 psi), minimum displacement of 150 l / min. and 30-liter tank, oil-free. Recommend use of coalescing filter in the air inlet of the equipment. Pipes: - Up to 10 meters: use hose ¼ "- 10 to 20 meters: use hose 5 / 16" Use specific woven hose for compressed air. For longer stretches, it is recommended project of distribution with specific rigid pipe.
- › **Piping:** - Up to 10 meters: 1/4 "hose; - From 10 to 20 meters: use a 5/16 "hose; Use a woven hose specifically for compressed air. For greater distances, a distribution design with specific rigid tubing is recommended.
- › **Water to Spittoon Bowl and Cup-filler:** install easy access key which will be used to stop the supply of water to the equipment at the end of the day and also to limit the water pressure, if necessary. The water pressure must to be between 2.8 and 6.0 bar and ideal pH between 6.5 and 8. If the water pressure is insufficient, we recommend consulting an experienced professional for hydraulic systems. We recommend the use of water filter in the input line of equipment.
- › **Sewage System:** the sewage net must present good hydraulic declivity and should preferably be installed underground. The nominal diameter of the tubing must be of 40 mm. Use independent branches for the sewage of the Water Unit.
- › **Power Supply:** the power net must be single phase, specifically grounded and must have thermal circuit breaker exclusive for the dental set. Should the power net present tension variations a power stabilizer must be installed. The circuit braker must be turned off everyday after work hours.
- › **Chair Fixation Points:** The chair must be fixed to the floor, except when using the optional rubber mat. Not observing this instruction will result in loosing the warranty.

CUSTOMER INSTRUCTIONS

- › **Able Professional Operation:** this equipment must be operated by professional who have the ability to work on dental procedures.
- › **Storage:** before the first operation or after long stop periods (weekends, holidays, vacations), the user must eliminate all air and water stuck inside the hoses, shut off the water-cocks, depressurize and empty the water tank, turn the general switch and the general circuit breaker off. For reactivation of the unit, verify the funtioning of the entire set before starting operation.
- › **Direct Exposure to Sunlight:** the equipment must not be exposed directly to solar light to prevent from the plastic covers and/or the upholstery to wear out precociously.
- › **Environmental Awareness:** the organic residues, the contaminated materials and disposable items must be properly eliminated according to the rules of the local law.
- › **Daily Cares:**
 - Replace the bottle water.
 - Daily cleaning of the venturi saliva ejector systems, vacuum pump and / or HVE hoses.
 - Cleaning of the debris collector, bowl and its finish.
 - Close water and compressed air records and turn off the equipment's power supply breaker after expedient.
 - Check the compressor before using the dental set.
 - Drain the compressor's moisture filter before using the dental set.

TROUBLESHOOTING TABLE - PART I

	Problems	Tests	Causes	Solutions
Chair	The chair does not carry out any commands	Check mains voltage	Off	Connect the mains
		Check the mains voltage rating	Electric voltage selected in the transformer is not selected according to the rated mains voltage	select the electrical voltage of the transformer, according to the mains electrical voltage
		Low mains voltage	Varying the input voltage in the equipment	Stabilize the mains voltage
		There is no electrical voltage in the transformer	Blown fuse	Replace the fuse, compatible with the mains electrical current.
		PC board does not light the LED indicators	There is no output voltage from the transformer to the board	Replacing the chair transformer
		Check pedal switches	Poor contact in the control micro switch	Replace control switch
		Measure Chair PC board input and output voltage	There is no output voltage from the PC board to the motors	Replacing the chair PC board
		Measure pedal PC board input voltage	Pedal PC board does not send commands to chair's PC board	Replace the pedal PC board
Chair	Chair seat or backrest does not move	Check fuse	Broken fuse	Replace the fuse as specified for the gearmotor
	Burning seat or back fuse	Check the current of the motor	Electric current above the rated fuse current	Lubricate the geared motor spindle. If not, replace the part.
		Check limit switch	When the motor reaches the limit switch, the limit switch is not activated	Troubleshoot poor contact between connectors and micro keys, align the micro key palette or replace a defective micro key.
Operating Light	Operanting light does not turn on the lamp	Check electrical contact of the switch	Poor contact of the micro switch	Reconnect electrical cable or replace micro switch if it is not closing contact.
		Check PC board output voltage	There is no voltage at the operanting light output on the PC board	Replace the chair PC board
			Broken operanting light fuse	Check equipment wiring harness and replace the operanting light fuse on the board
		Electric voltage of the PC board does not reach the operanting light head	Broken cable	Connect the electrical cable.
		Check chair PC board tension selection mode	Chair PC board has the operanting light output in a mode that is not suitable with the operanting light voltage.	Select the operanting light output according to the head LED's rated voltage
Water Unit and Assistant Module	Cuspidor does not come out water	Electric voltage does not reach the head PC board	Broken fuse	Replace fuse as specified for operanting light.
		Check mains water valve	Closed water supply.	Open mains water record
		Check mains water supply	Lack of water or air in the pipeline	Wait for water supply or remove air from the pipeline, releasing the flow.
		Open the cuspidor water valve	Dirt in the sieve and solenoid valve tubing	Clean the solenoid valve sieve and tubing
		Check electrical output voltage of the board	Electric voltage does not reach the solenoid coil of the valve	Reconnect electrical cables and establish rated electrical voltage to the solenoid valve
	Check voltage and current of the solenoid switch	Burnt solenoid valve	Replace the valve solenoid	

TROUBLESHOOTING TABLE - PART II

	Problems	Tests	Causes	Solutions
Water Unit and Assistant Module	Curing light does not work	Check transformer output voltage and cables	No electrical voltage reaches the curing light PC board	Reconnect electrical cable from light curing harness
	Curing light does not work, does not turn on the LED	Check input voltage on the curing PC board	Nominal electrical voltage arrives from the transformer, but does not turn on the light curing LED	Replace curing PC board
	Ejector doesn't work	Check compressor air pressure	Lack of air pressure from the compressor	Start the compressor, open the valve and establish the air flow
		Check venturi ejector	Dirt in the ejector tip	Clean the suction air nozzle
		Check instrument support valve	Locked valve plunger	Open the valve and repair the plunger
	Ejector does not close	Check instrument support valve	Valve does not close when the suction connector is attached to the holder	Adjust instrument support valve
		Check instrument holder reed	Support vane broken. Does not close the air passage when the suction device is placed in the holder	Replace vane and adjust the suction support valve
	Ejector is weak or losing suction during use	Check ejector filter	Clogged filter	Clean the ejector filter
		Check air pressure	Pressure below specification coming from the compressor	Adjust the air pressure of the compressor and chair filter
		Check ejector sewer draining hose	Clogged hose	Clean sewer suction hose from ejector
	Ejector exiting air through the connector instead of suck	Check venturi ejector in the sewer connection box	Clogged sewer	Unclog sewer, clean ejector and connection box
		Check venturi ejector in the sewer connection box	Sucker outlet hose bent or obstructed	Unfold and clean the venturi ejector hose
	Bicarbonate jet (prophylaxis) does not work	Check reservoir air pressure	No air pressure at the powder tank inlet	Adjust VRP2 air pressure
		Check bicarbonate powder reservoir	Reservoir outlet clogged	Unclog bicarbonate output valve
		Check triple hose	Hose clogged with baking powder	Unclog triple hose
		Check instrument support valve	Support valve with plunger locked	Adjusting the instrument support valve plunger
	Bicarbonate jet (prophylaxis) working at the same time as another hand instrument	Check pedal valve	Pedal valve without air pressure	Replace progressive pedal valve plunger
		Check instrument support valve	Instrument support valve does not close fully	Adjust instrument support valve
	Bicarbonate jet (prophylaxis) leaving water after use	Check suction valve	Suction valve plunger takes a long time to return	Clean and lubricate rubber rings on the suction valve
	Vortex suction does not work	Check chair's electrical tension	Chair on / off button off	Turn on / off button of the chair base
Check chair board input and output voltage		Chair PC board does not release the rated voltage for the vortex air solenoid valve	Replace the chair PC board or the timed vortex suction PC board if it is not the same model.	
Check the air solenoid valve of the vortex system		Solenoid coil receives the nominal voltage from the PC board, but does not open the valve plunger	Replacing the vortex suction air solenoid valve	
Vortex suction does not turn off, after placing in the holder	Check trigger button	On / off button has not been turned off	Step on the chair base button or joystick to turn the vortex system off	

TROUBLESHOOTING TABLE - PART III

	Problems	Tests	Causes	Solutions
Delivery Unit Platform	Flex arm does not lock the tray in the working position	Check air pressure of the equipment	Team without air pressure or with insufficient pressure	Start the compressor, open the regulator to regulate the air pressure of the equipment
		Check flex arm brake	Air leak in the flex arm brake	Replace flex arm brake
		Check the brake arm spring pressure	Low pressure on the flex arm brake spring	Adjust the brake arm spring pressure
		Check the (capacitive) touch sensor	Capacitive sensor sending direct electrical voltage to the sensor solenoid valve	Replacing the (capacitive) touch sensor
	Flex arm brake touch sensor does not trigger	Check the touch sensor solenoid valve	Touch sensor valve is not closing the air flow	Replacing the touch sensor solenoid valve
		Check input voltage on the touch (capacitive) sensor PC board	The rated voltage does not reach the touch (capacitive) sensor board	Connect electrical cable and establish the nominal electrical voltage of the PC board.
		Check equipment electrical ground	Poor sizing or lack of grounding in the electrical network	Resize or install the electrical ground in the Equipment outlet / connector
	Equipment does not respond to commands from the Touch Panel	Check touch (capacitive) sensor PC board	Touch (capacitive) sensor does not respond when receiving electrical voltage	Replacing the (capacitive) touch sensor
		Check electrical harness contacts	Touch PC board does not receive electrical voltage from the chair PC board	Reconnect cables and establish electrical voltage from the chair PC board to the touch
	Equipo operating light and tray do not stop at work positions	Check working table touch PC board or assistant module	Chair PC board does not receive commands from the Touch PC board.	Replace the touch PC board of the chair or assistant module
Check the leveling of the equipment structure		Operating light arm column and Equipo are out of level in the vertical position	Retighten the fixing screws of the Equipo to the chair to level the structure	
Working Table	Air leakage through the Equipo water tank cover	Check tank cap rubber ring	Tank cover rubber ring is worn, causing air leak	Replace O'ring on the delivery unit water tank cap
		Check tank cap connection	Connection with broken weld	Replacing the Water Tank Cover Connection
	Scaler does not work	Check mains voltage	Mains voltage is not connected or is below 10% nominal	Establish electrical voltage from the mains to the equipment
		Check electrical supply voltage of the board	Electrical voltage below the nominal scaler PC board or poor electrical contact	Establish rated electrical voltage to the scaler board, check connectors and reconnect electrical cables
		Check electropneumatic valve	Electropneumatic valve is not operating.	Check and restore sufficient air pressure to activate the valve and / or check whether the valve closes the electrical contact. Replace valve.
		Check scaler PC board	Scaler board receives the nominal voltage from the transformer, but no electrical voltage is output to the transducer (pen)	Replace the PC board's fuse. And when there is no fuse, replace the scaler PC board
		Check scaler hose	Electric scaler hose cable is broken	Replace the scaler hose
		Check scaler instrument holder NC switch	Switch is locked does not release electrical control when the pen is removed from the holder	Unlock the button or replace the scaler holder microswitch
		Check scaler transducer (pen)	Nominal electrical voltage reaches the transducer, but the insert (tip) does not vibrate	Check that the insert is firmly attached to the transducer. If the problem persists, replace the transducer.
		Check scaler potentiometer	No voltage reaches the scaler transducer	Replace scaler potentiometer

TROUBLESHOOTING TABLE - PART IV

	Problems	Tests	Causes	Solutions
Working Table	Weak scaler	Check electrical voltage of the scaler PC board	Electrical voltage is below the nominal	Replacing the scaler PC board
		Check potentiometer	Potentiometer does not select the power for that insert model (tip)	Replace scaler potentiometer
		Check scaler tip	Insert (tip) was not threaded until the end of the transducer shaft thread	Use the torque wrench to thread the insert on the scaler transducer (pen) shaft
			Internal thread of the insert (tip) is not compatible with the external thread of the scaler transducer (pen)	Replace the insert (tip), using the compatible model the thread of the scaler transducer
	Scaler does not come out of water	Check scaler water valve	Scaler water valve closed or dirty obstructing the water outlet	Open the scaler water valve and do internal cleaning
		Check the scaler PC board	The scaler PC board is not receiving rated voltage from the transformer	Repair electrical connection between transformer and scaler PC board
			Scaler PC board does not release rated voltage to the solenoid valve	Replacing the scaler PC board
	Electric micromotor does not work	Check scaler water solenoid valve	Scaler solenoid valve receives nominal voltage from the PC board, but does not open the plunger of the water valve	Replacing the scaler water solenoid valve
		Check the equipment's electrical input network	Mains disconnected or destabilized	Turn on equipment or stabilize power grid
		Check micromotor rotation switch	Inverter switch (FWD / REV) is in the OFF position	Select the key for the desired rotation FWD or REV
		Check air pressure of the electropneumatic valve	No air pressure or insufficient pressure in the electropneumatic valve	Adjust air pressure in the electropneumatic valve
		Check electropneumatic valve switch	No electrical voltage arrives in the electropneumatic valve micro switch	Reconnect cables and establish rated voltage in the electropneumatic micro switch
Check electric micromotor PC board		Nominal voltage does not reach the electric micromotor board	Connecting cables and establishing nominal input voltage on the electric micromotor board	
		The board receives electrical voltage but does not send to the electric micromotor	Replacing the electric micromotor PC board	
Check micromotor rotation switch		Inverter switch (FWD / OFF / REV) with poor contact	Replacing the electric micromotor inverter switch	
Check electric micromotor potentiometer		Potentiometer with poor contact	Replace electric micromotor potentiometer	
Check micromotor cable		Electrical cable with bad contact or broken	Repair or replace the electric micromotor cable	
Check electric micromotor	Micromotor rotor (handpiece) is locked	Replace electric micromotor		
	Check contra-angle or straight handpiece	Contra-angle with the cartridge locked or straight handpiece with the drive shaft locked	Repair or replace contra-angle cartridge or transmission shaft of straight handpiece	
		Contra-angle or straight handpiece with crushed turbine head	Repair or replace contra-angle or straight handpiece	

TROUBLESHOOTING TABLE - PART V

	Problems	Tests	Causes	Solutions
Working Table	Weak electric micromotor, low speed or failing	Check the electrical voltage of the micromotor PC board	Electric voltage is below the nominal for the micromotor operation	Establish rated electrical voltage of the equipment
		Check air pressure of the electropneumatic valve	Lack or low air pressure in the electropneumatic valve	Adjust air pressure in the electropneumatic valve
		Check electric micromotor potentiometer	Potentiometer is set to minimum power	Adjust the potentiometer to the desired RPM speed
			Selector switch power variation failure	Replacing the micromotor power adjustment switch
	Thermo Comfort does not heat the syringe water	Check electrical voltage in the water heater	Nominal electrical voltage does not reach the heater	Reconnect cable and establish the rated electrical voltage of Thermo Comfort
		Check water heater lamp (Boiler)	Boiler halogen lamp is burned out	Replacing the water tank lamp
		Check on / off switch	Switch off	Turn on heater switch
	Low and high speed pneumatic turbines are weak	Check compressed air compressor	Compressor off	Check the sizing and condition of the compressor power supply circuit breaker. Turn on the circuit breaker.
			Insufficient pressure at the compressor outlet	Adjust the outlet pressure of the compressor air filter
			Starting the engine with dynamic pressure below the minimum recommended in the equipment user manual	Adjust the pressure switch to start the compressor motor with dynamic pressure reaching 5.5 bar (80 psi)
Compressor with low power and displacement below the recommended for the type of equipment			The compressor must have a minimum displacement of 150 l / min.	
Inadequate compressed air piping the distance between the equipment and the compressor			The air tubing must have the diameter according to the measures specified in the equipment user manual.	
Check air filter		Air filter near the equipment has a static pressure below 5.5 bar (80 psi)	Adjust the air filter to 5.5 bar (80 psi) next to the equipment	
Check the pressure regulating valve (VRP1)		The regulating valve (VRP1) has low pressure	Adjust the valve (VRP1) so that the dynamic working pressure of the low speed is 2.4 bar (35 psi) using the gauge on the turbine	
		Valve (VRP1) does not regulate	Replacing the air reduction valve seal	
Check the pressure regulating valve (VRP1) and air choke for the high speed turbine		The regulating valve (VRP1) has low pressure and a choke with little air flow	Set the working pressure of the handpieces.	
Check adjustment of the valves of the instrument holder		Valves on the instrument supports are out of order	Adjust the valves so that the vanes close the air of the instruments when they are in the supports	
Check the air propulsion pedal	Progressive pedal valve losing pressure or low air flow	Replacing the progressive pedal valve		

TRUBLESHOOTING TABLE - PART VI

	Problems	Tests	Causes	Solutions
Working Table	Lack of water spray on the turbines	Check compressor	Low air pressure at the filter outlet	Adjust the air filter to the rated working pressure
		Check equipment air valve	Closed tank air valve	Open the air valve to pressurize the water tank
		Check the Equipo air pressure regulating valves	Low air pressure in the tank	Adjust the Equipo's VRP1 valve and the high-speed turbine air choke with the pressure gauge. Then the tank VRP2 and the spray choke
		Check triple tap	Triple tap with closed water valve	Open the triple tap water valve
		Check turbine (pen)	Turbine (pen) with the spray outlet clogged	Unclog outlets of turbine water spray (pen)
	Instruments on the stand start when the propulsion pedal is depressed or when using another handpiece	Check instruments holder valves on the delivery system	Support valves or microswitches do not close completely when they are with the instruments	Adjust the valves of the instrument holders so that the vanes close the valves fully when they are with the handpieces
	Turbine drips after use or when in the tip holder (Cross)	Check the water suction valve	The internal plunger of the water suction valve is locking	Open the water suction valve and lubricate the sealing rings. If not, replace the valve
	Syringe does not come out air and water	Check compressor air pressure	Compressor air flow interrupted	Establish air flow by turning on the compressor or adjusting the filter.
		Check air pressure of the equipment	Air valve of the water tank is closed	Open the water tank air valve
	Syringe locking air and water buttons	Check 3-way syringe	3-way syringe head with stroke marks / dented	Rectify the button fittings, if not resolved, replace the 3-way syringe
			Lack of lubrication on the buttons	Lubricate the 3-way syringe buttons, if not resolved, replace the syringe
	Syringe leaving water when pressing the air button	Check compressed air compressor	Water in the compressor air tank	Drain the reservoir, replace or replace the air filter. If the compressor is too far from the equipment, place a filter on the chair.
	Leakage of water through the fitting of the 3-way syringe tip	Check the 3-way syringe	Clearance in the metal ring of the syringe tip	Tighten the metallic ring on the tip of the 3-way syringe
			The base of the 3-way syringe tip is broken	Replacing the 3-way syringe tip
	Brushless electronic micromotor will not start	Check electrical network	Mains disconnected or with voltage below that specified for the equipment	Connect or stabilize the equipment's electrical network
Check fuse and electrical voltage of the base of the chair		Blown chair base fuse	Replace fuse according to the mains voltage. Test electrical harness	
Brushless electronic micromotor will not start	Check equipment harness	Nominal electrical voltage of the transformer does not reach the electronic micromotor PC board	Retighten connectors and establish nominal electrical voltage between the transformer and the electronic micromotor PC board	
	Check equipment air pressure	Compressor off or low air pressure in the Equipo, not activating the electronic micromotor PC board sensor	Switch on the compressor and regulate the air pressure of the equipment	
	Check instrument support valve	Delivery system air does not reach the electronic micromotor PC board pressure sensor	Check the air pressure of the Delivery System, reduction valve (VRP1), pedal valve and instrument holder	

TROUBLESHOOTING TABLE - PART VII

	Problems	Tests	Causes	Solutions
Working Table	Brushless electronic micromotor failing the turbine or turning the drill	Check electronic micromotor PC board	Electronic PC board does not release rated voltage to the micromotor (handpiece)	Replacing the electronic micromotor PC board
		Check the selection mode of the electronic micromotor control panel	The selection mode is not suitable for the contra-angle in use	Select the working mode and RPM for the contra-angle in use 1: 1, 1: 5 or 20: 1 on the control panel
		Check contra-angle	Contra-angle with hit / hit mark on the turbine head	Rectify the part, if not resolved, replace the contra-angle
		Check electrical voltage of the electronic micromotor PC board	Low nominal voltage from the electronic PC board output to the micromotor	Replacing the electronic micromotor PC board
	Brushless electronic micromotor does not come out of water	Check reservoir and air valve of the delivery system	Tank air valve is closed	Open air valve of the delivery system tank
		Check water record of electronic micromotor	Dirt inside the water register of the electronic micromotor	Open the water register of the micromotor and perform cleaning
	Brushless electronic micromotor heating the contra-angle head	Check the selection mode of the electronic micromotor control panel	The selection mode is not suitable for the contra-angle in use	Select the working mode and RPM for the contra-angle in use 1: 1, 1: 5 or 20: 1 on the control panel
		Check contra-angle	Lack of lubrication of the drive shaft and cartridge	Lubricate the contra-angle after each service
	ChronoLub system remains beeping continuously	Check ChronoLub PC board programming	ChronoLub system has not been rebooted (RESET / ESC button) after instrument lubrication	After lubricating the pen, press the RESET / ESC button on the ChronoLub panel

<i>Revisions Program - Chair and Delivery Unit - Part I</i>	180d	360d	540d	720d	900d
CHAIR					
Checking of all movements	✓	✓	✓	✓	✓
Headrest checking	✓	✓	✓	✓	✓
Armrest checking	✓	✓	✓	✓	✓
Checking the valve and pedal handle	✓	✓	✓	✓	✓
Articulation axes lubrication	✓		✓		✓
Electrical motor/ spindle drive lubrication		✓		✓	✓
WATER UNIT / ASSISTANTE MODULE					
Articulation axes verification / lubrication	✓	✓	✓	✓	✓
Castors checking (Kart)	✓	✓	✓	✓	✓
Handpieces pressure checking	✓	✓	✓	✓	✓
O´rings coupling for handpieces checking and lubrication	✓	✓	✓	✓	✓
Micropilot valve of the handpiece holder checking	✓	✓	✓	✓	✓
Electric-pneumatic valves cheaning and lubrication	✓	✓	✓	✓	✓
Instrument Articulators (Cross) Checking	✓	✓	✓	✓	✓
Touch Commands Checking	✓	✓	✓	✓	✓
Disassembles and lubrication the syringe buttons		✓		✓	✓
Handpieces' Hoses Checking		✓		✓	✓
Wear out of Scaler Tips control		✓		✓	✓
Flex Arm movements and Brake checking		✓		✓	✓
X-ray viewer activation button checking		✓		✓	✓
Checking the prophylaxis reservoir lid ring		✓		✓	✓
Checking the prophylaxis hose	✓		✓		✓
Checking the trim of the prophylaxis pen		✓		✓	✓
OPERATING LIGHT					
Verification of joint movements	✓	✓	✓	✓	✓
Verification of available intensities	✓	✓	✓	✓	✓
Focus check	✓	✓	✓	✓	✓
Lamp / LED Rating		✓		✓	✓
Screen / mirror check			✓		✓

<i>Revisions Program - Chair and Delivery Unit - Part II</i>	180d	360d	540d	720d	900d
WATER UNIT / ASSISTANTE MODULE					
Movements checking	✓	✓	✓	✓	✓
Suction 250 to 300 mm/hg checking	✓	✓	✓	✓	✓
Lubrication of the saliva ejector´s filter O'rings	✓	✓	✓	✓	✓
Disassembles, cleaing and lubricating of the bowl O'ring	✓	✓	✓	✓	✓
Strainer Checking	✓	✓	✓	✓	✓
Blade for instruments holder checking	✓	✓	✓	✓	✓
Articulation Lubrication	✓	✓	✓	✓	✓
Prophylaxis' Hose checking	✓		✓		✓
Disassemble and lubricating the syringe buttons		✓		✓	✓
Checking of guarnition for prophylaxis' instrument		✓		✓	✓
Prophylaxis' System Reservoir O'ring checking		✓		✓	✓
Air vaccum tubes checking		✓		✓	✓
STOOL					
Castors checking	✓	✓	✓	✓	✓
Checking the piston and movements	✓	✓	✓	✓	✓
CURING LIGHT					
Verification of intensity and operating programs	✓	✓	✓	✓	✓
Checking tip and support ring	✓		✓		✓
JUNCTION BOX					
Air, Water and Vacuum hose checking	✓	✓	✓	✓	✓
Sewer Connector Checking and Cleaning	✓	✓	✓	✓	✓

<i>Features - Chair</i>	
Electrical	
Power supply	118, 127, 220 and 230 VAC; The voltage must be selected at installation. Note: All equipment leaves the factory set to 220VAC.
Number of phases	Single phase
Frequency	50/60 Hz
Power	124,2 VA
Maximum Equipment Voltage	24V
Chair and Equipment Fuses	Fast Acting Fuses
- F1 Chair	1.5A to 220VAC / 230VAC 3A to 118VAC / 127VAC
- F2 Connection Box	10A
PC Board Fuses	
- F1 and F2	3,5A Delayed Fuse
- F3 Operating Light	3,15A Fast Acting Fuse
Mechanical	
Protection type against electric shock	Class I equipment according to IEC 60601-1-1 and IEC 60601-1-2
Protection Degree	Type B
Operation mode	Intermittent
Protection against harmful water penetration	IPX0
Transformer thermal protection	Aperture at 130°C ±3%
Lifting capacity	150 kg
Water tank capacity	1000ml
Operation light's intensities	8.000 to 30.000 Lux;
Seat height in relation to the floor	Minimum 44 cm; Maximum 72cm
Gross weight	163 kg
Storage temperatures	-30°C to 45°C
Working temperatures	2°C to 45°C
Mechanical Structure	Laminated steel strip SAE 1020
Welding	MIG
Painting	Electrostatic Painting with Polyurethane
Material of Plastic Covers	High Impact Pigmented Polystyrene
Material of the other plastic parts	ABS, PP, Polyacetal and TPE

Features - Accessories

Connections

Electric	Flexible tube ¾"
Pneumatic	Flexible tube ¾"
Sewer connection	DN 40mm
Water tubing	Welding ø 25mm rigid PVC tube with the L/R 25 x ½" terminal

Curing Light

Power supply	24VAC - 50Hz/60Hz
Power	8W
Operation mode	Continuous, ramp and pulsed
Light power	Fiber Optics probe (tip) 1000-1200 mW/cm ²
Wave length	420-480 nm
Timer	20 seconds

VALO Curing Light

Power supply	9VCC
Power	18W

Scaler

Power supply	24VAC - 50Hz/60Hz
Frequency	28kHz ±3kHz
Power	3 to 20 W

Electrical Micromotor

Power supply	24VAC - 50Hz/60Hz
RPM	0-35.000 RPM
Max. Power	60W
Torque	270g-cm

Brushless Micromotor

Light's intensities	25.000Lux
	20:1: -- 100-2.500 RPM
RPM	1:1: -- 2.000-40.000 RPM
	1:5: -- 10.000-200.000 RPM
Max. Power	120W
Torque	~3,5Ncm

High Speed Turbine with Fiber Optics

Power supply	24VAC - 50Hz/60Hz
LED Voltage	3,3VCC
LED power	2W

X-Ray

Power supply	24VAC - 50Hz/60Hz
Power	4W

Thermo Comfort

Power supply	12VAC - 50Hz/60Hz
Power	50W

Anti-Stress

Power supply	12VCC
Power	15W

AirJet

Power supply	24VAC
Solenoid voltage	32VCC
Power	10W

SPRINT T - SIDE VIEW

Measures in millimeters

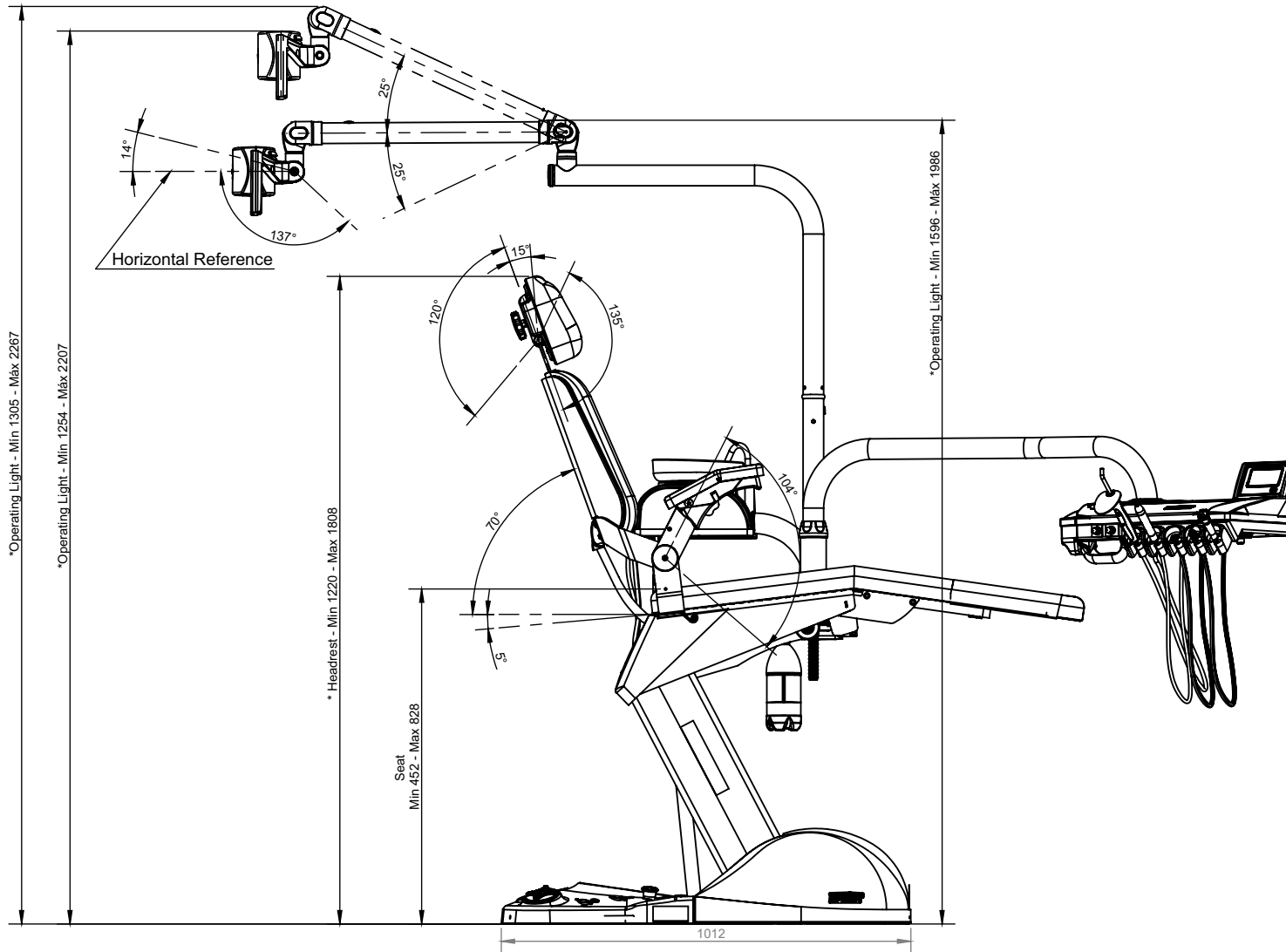

SPRINT T - UPPER VIEW

Measures in millimeters

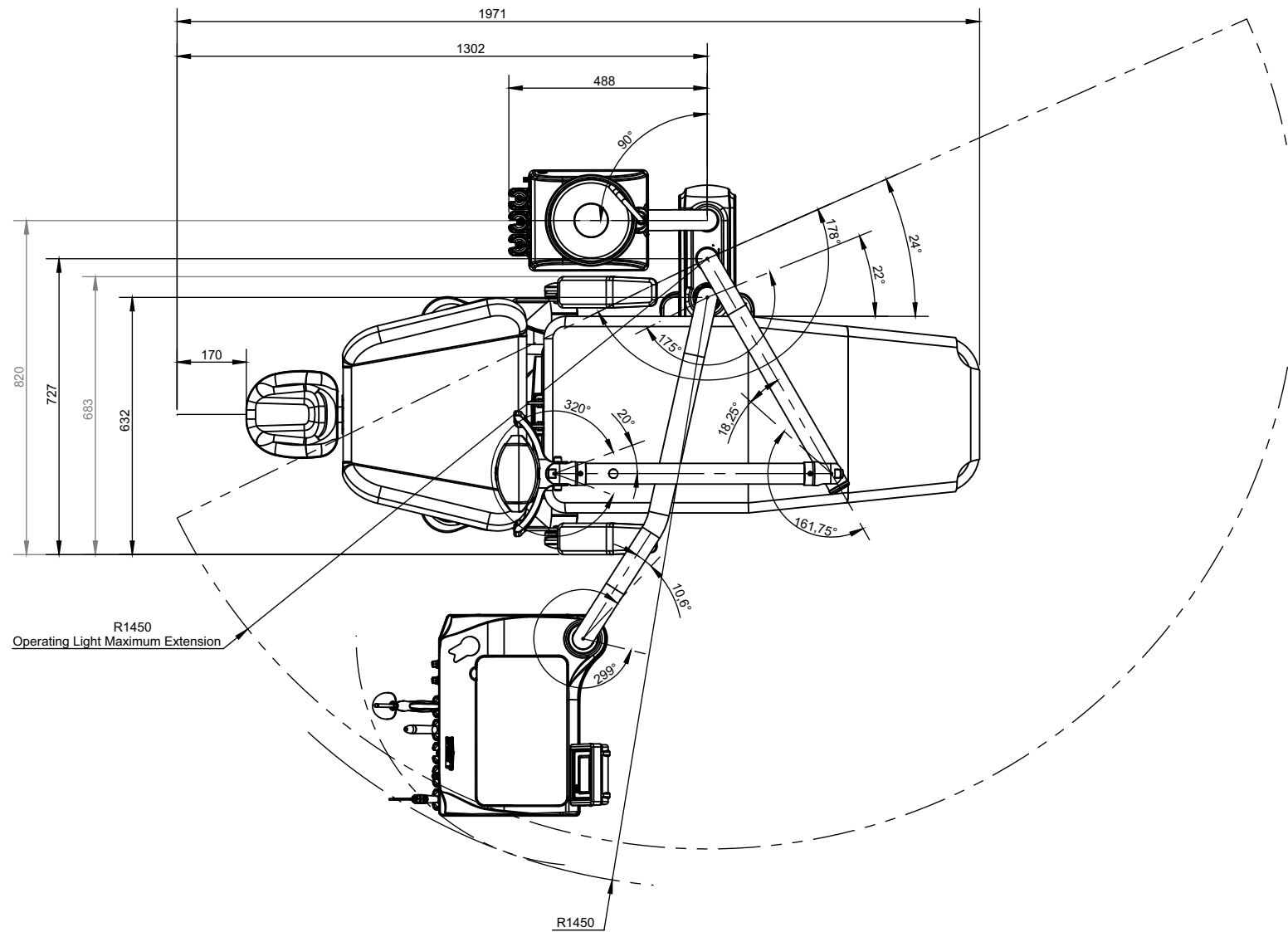

SPRINT - SIDE VIEW

Measures in Millimeters

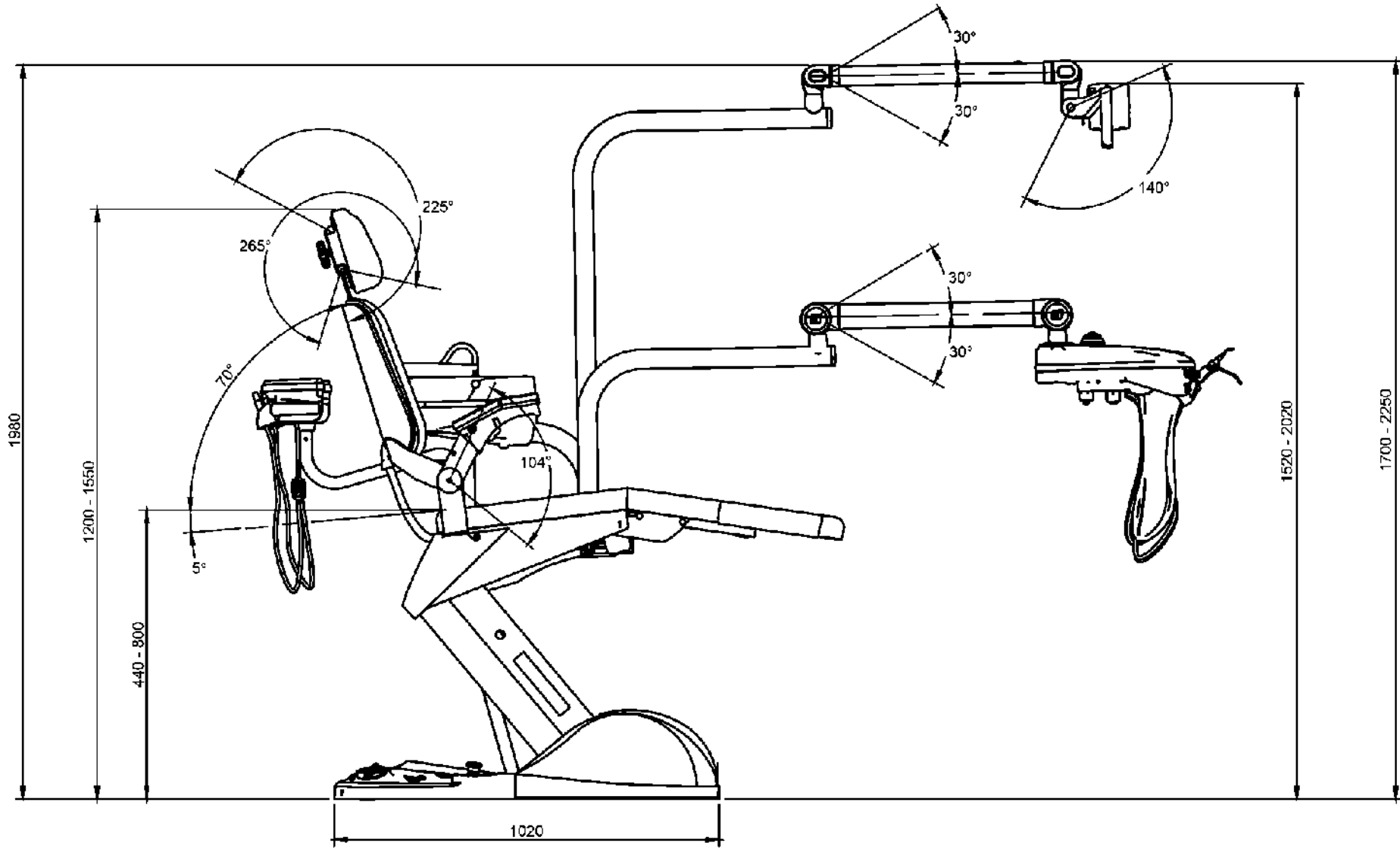

SPRINT - UPPER VIEW

Measures in Millimeters

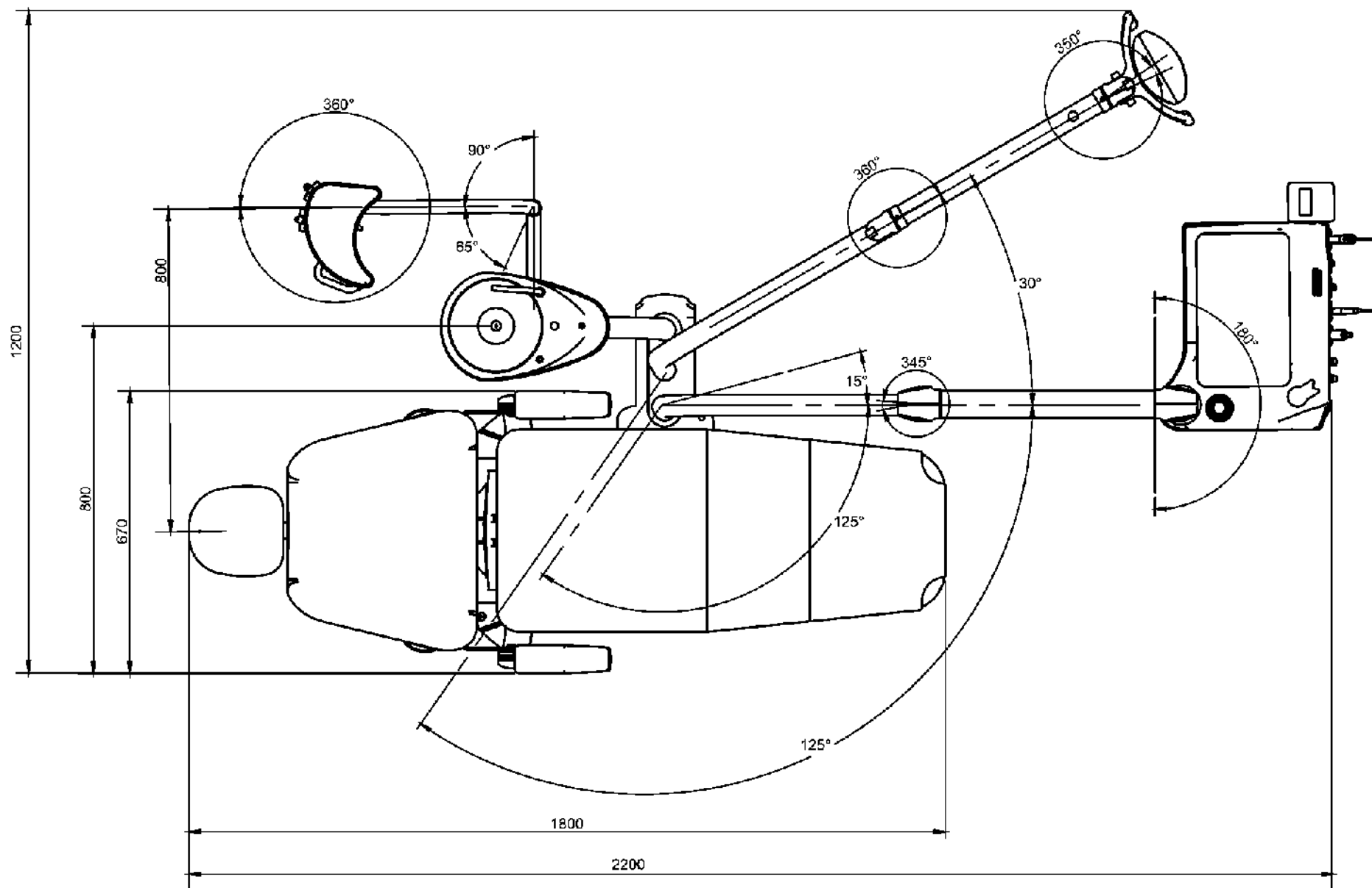

ELECTRICAL DIAGRAMS

- › **5401166 - R00 - Electrical Diagram SPS 22** 57 a 72
- › **5401163 - R00 - Electrical Diagram with Pedal SPS 22** 73 a 87
- › **5401164 - R00 - Electrical Diagram with Touch SPS 22** 88 a 103
- › **5401165 - R00 - Electrical Diagram with Touch and Pedal SPS 22** . 104 a 118

HYDROPNEUMATIC DIAGRAMS

- › **5406088 - R04 - Hydropneumatic Diagram for Dental Line** 119 a 137

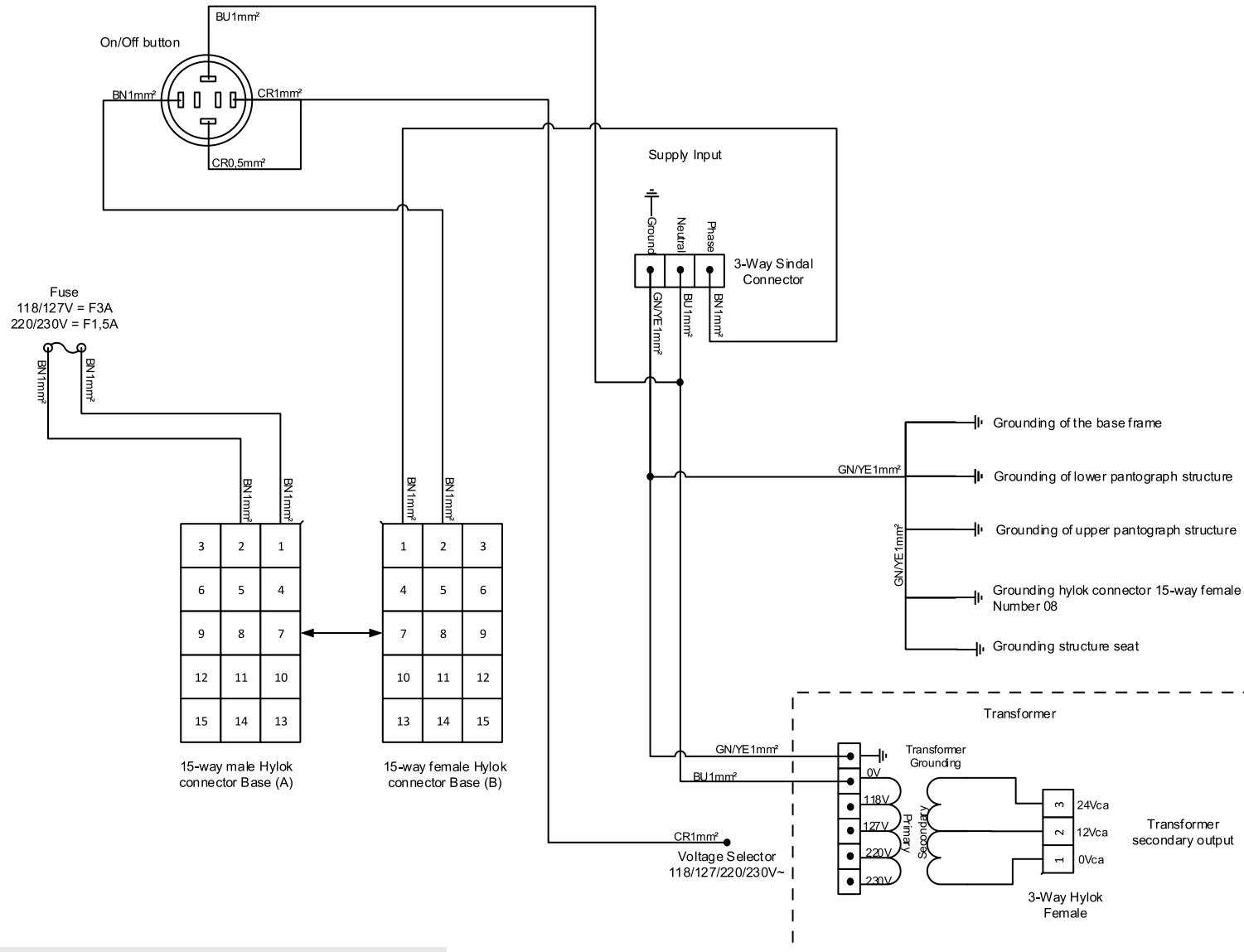

Color Legend	
Black	BK
Red	RD
Blue	BU
Green	GN
White	WH
Brown	BN
Violet	VT
Crystal	CR
Orange	OG
Yellow	YE
Pink	PK
Grey	GY
Green/Yellow	GN/YE
Blue/White	BU/WH
Red/White	RD/WH

Chair
 -Electrical part + Grounding
 -Optional items according to the equipment configuration grid

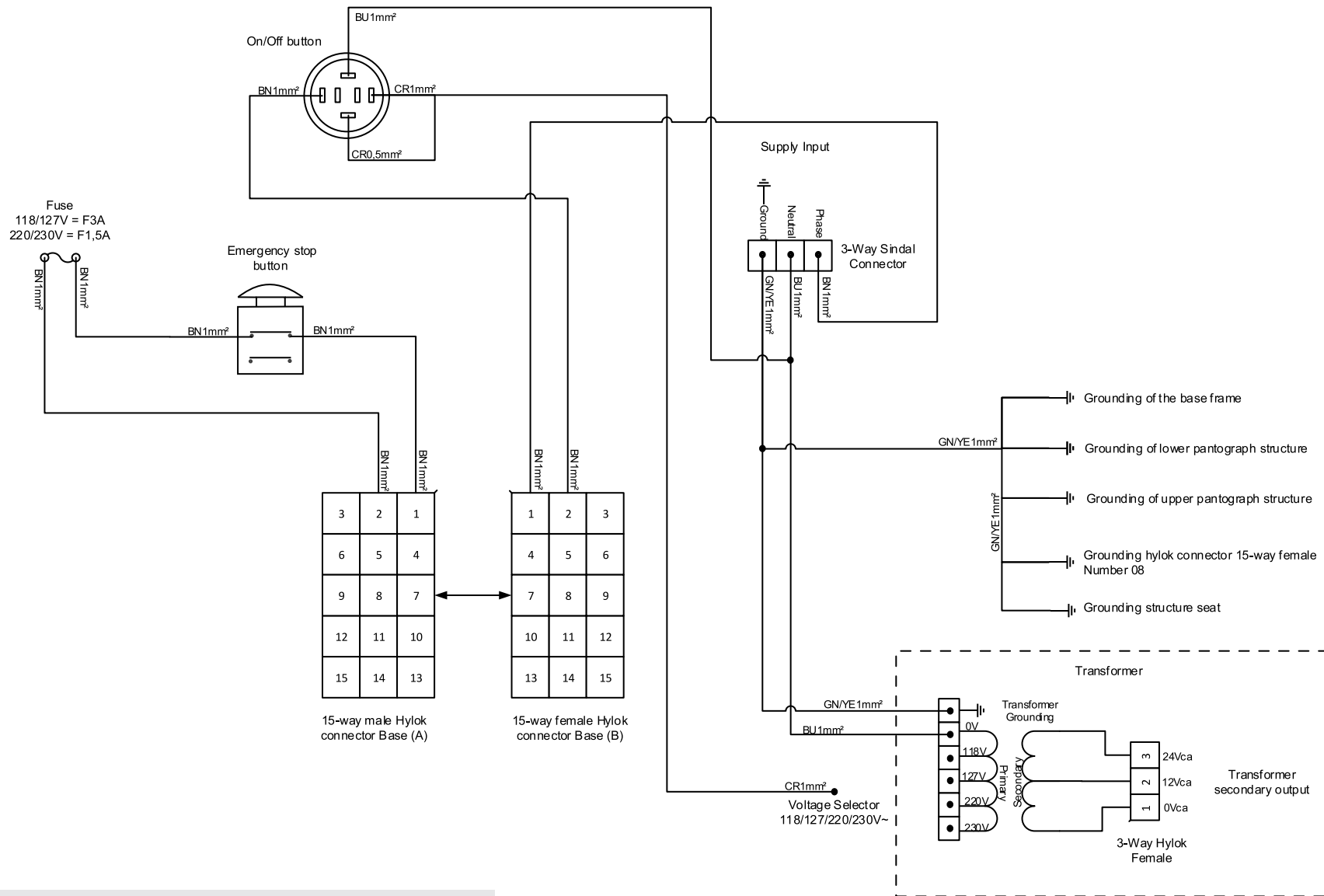

Color Legend	
Black	BK
Red	RD
Blue	BU
Green	GN
White	WH
Brown	BN
Violet	VT
Crystal	CR
Orange	OG
Yellow	YE
Pink	PK
Grey	GY
Green/Yellow	GN/YE
Blue/White	BU/WH
Red/White	RD/WH

Chair
 -Electrical part + Grounding + Emergency stop button
 -Optional items according to the equipment configuration grid

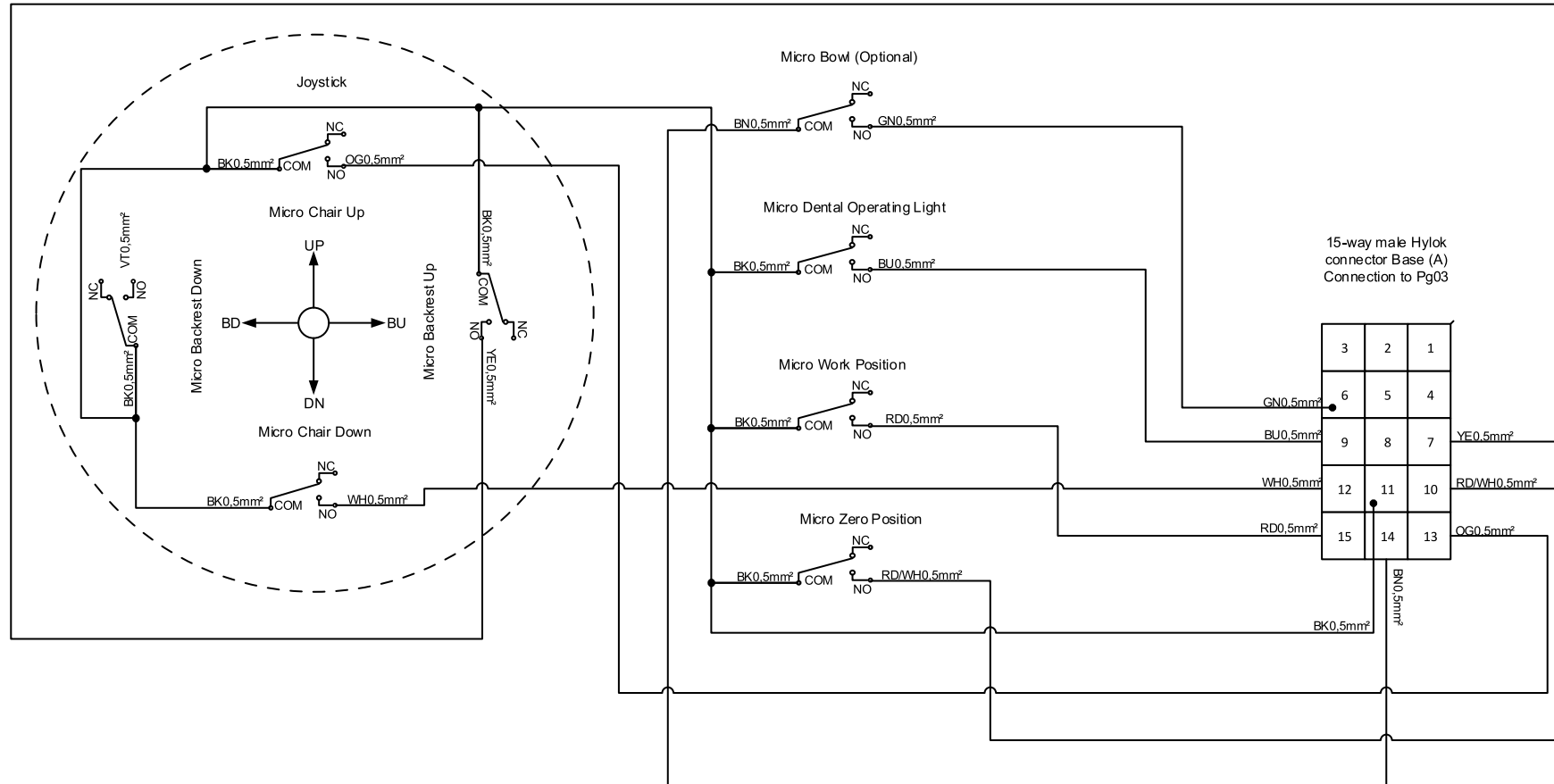

Color Legend	
Black	BK
Red	RD
Blue	BU
Green	GN
White	WH
Brown	BN
Violet	VT
Crystal	CR
Orange	OG
Yellow	YE
Pink	PK
Grey	GY
Green/Yellow	GN/YE
Blue/White	BU/WH
Red/White	RD/WH

Connection of «Base» chair controls
 -Optional items according to the equipment configuration grid

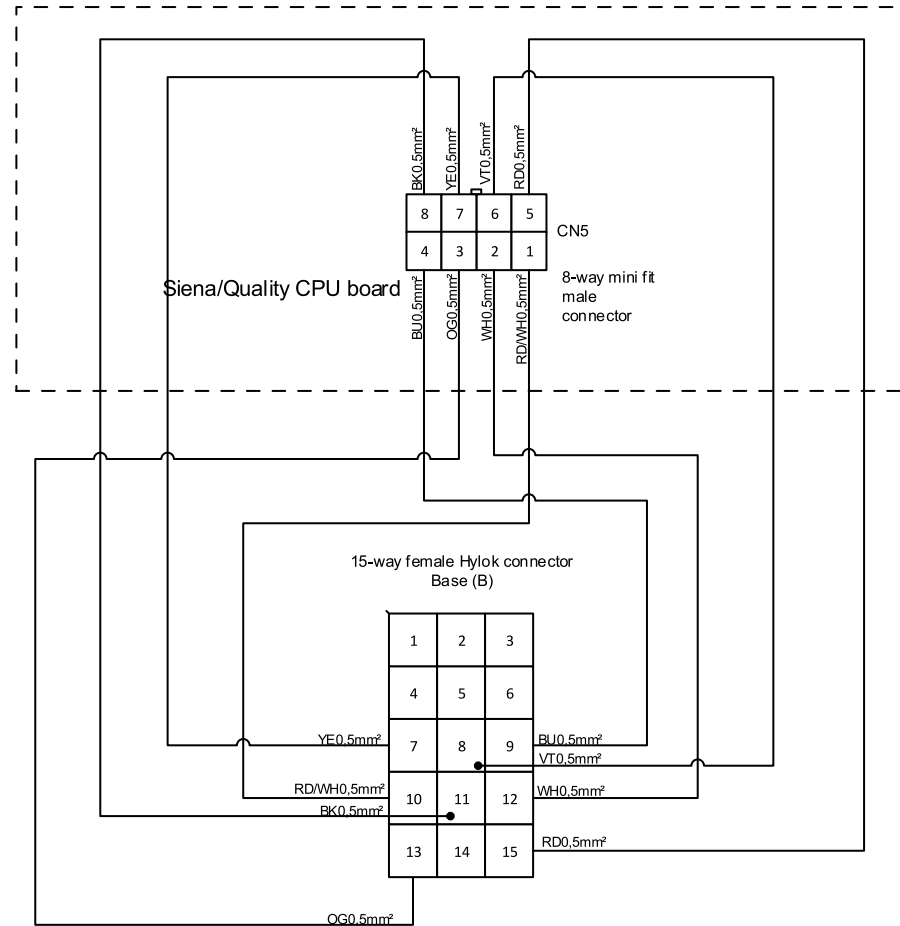

Color Legend	
Black	BK
Red	RD
Blue	BU
Green	GN
White	WH
Brown	BN
Violet	VT
Crystal	CR
Orange	OG
Yellow	YE
Pink	PK
Grey	GY
Green/Yellow	GN/YE
Blue/White	BU/WH
Red/White	RD/WH

Connection of "Base" chair commands on the PC board
 -Optional items according to the equipment configuration grid
 -When using Vortex the Bowl command stops for the water unit

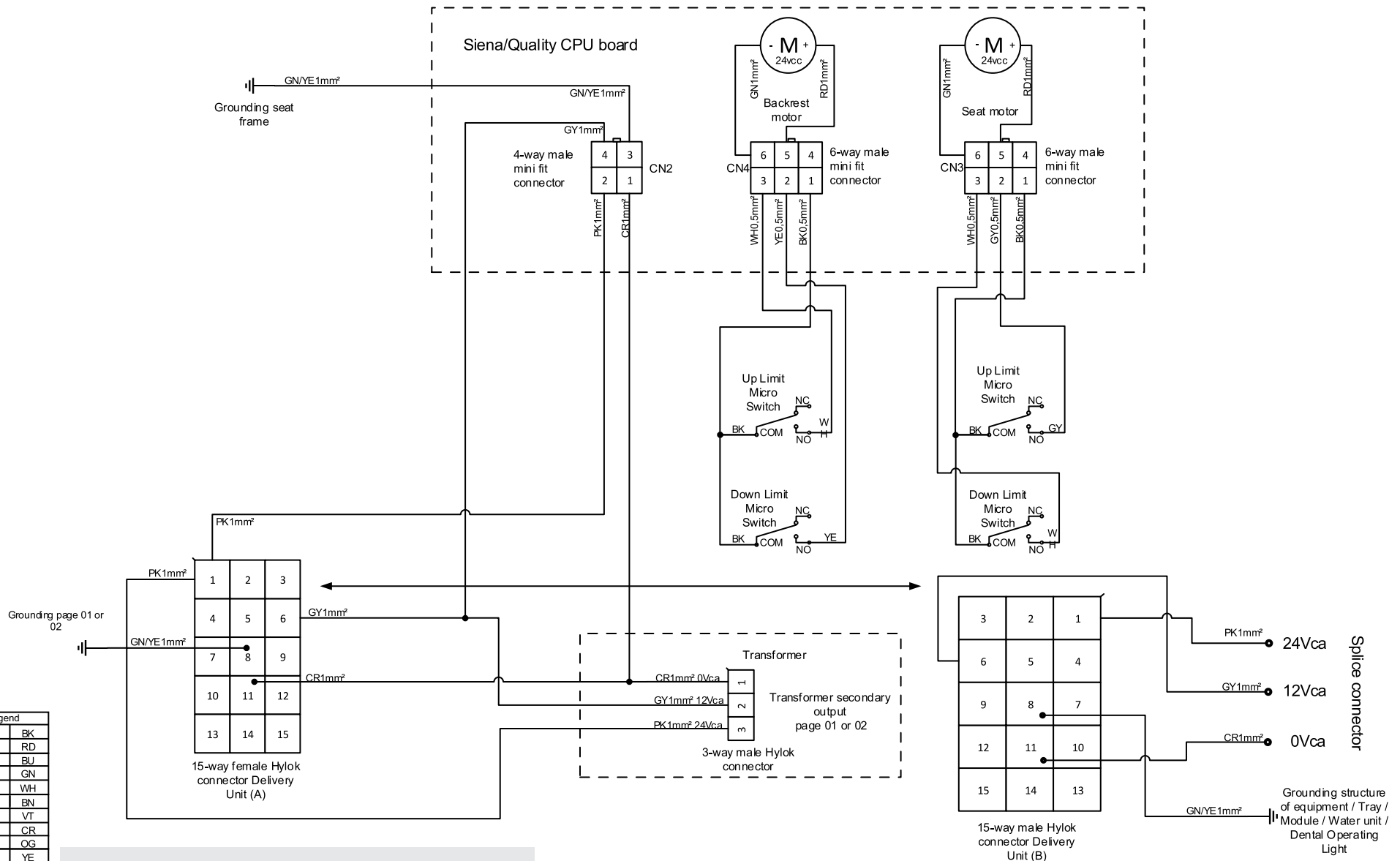

Color Legend	
Black	BK
Red	RD
Blue	BU
Green	GN
White	WH
Brown	BN
Violet	VT
Crystal	CR
Orange	OG
Yellow	YE
Pink	PK
Grey	GY
Green/Yellow	GN/YE
Blue/White	BU/WH
Red/White	RD/WH

Connection CPU PC board and Motors
-Optional items according to the equipment configuration grid

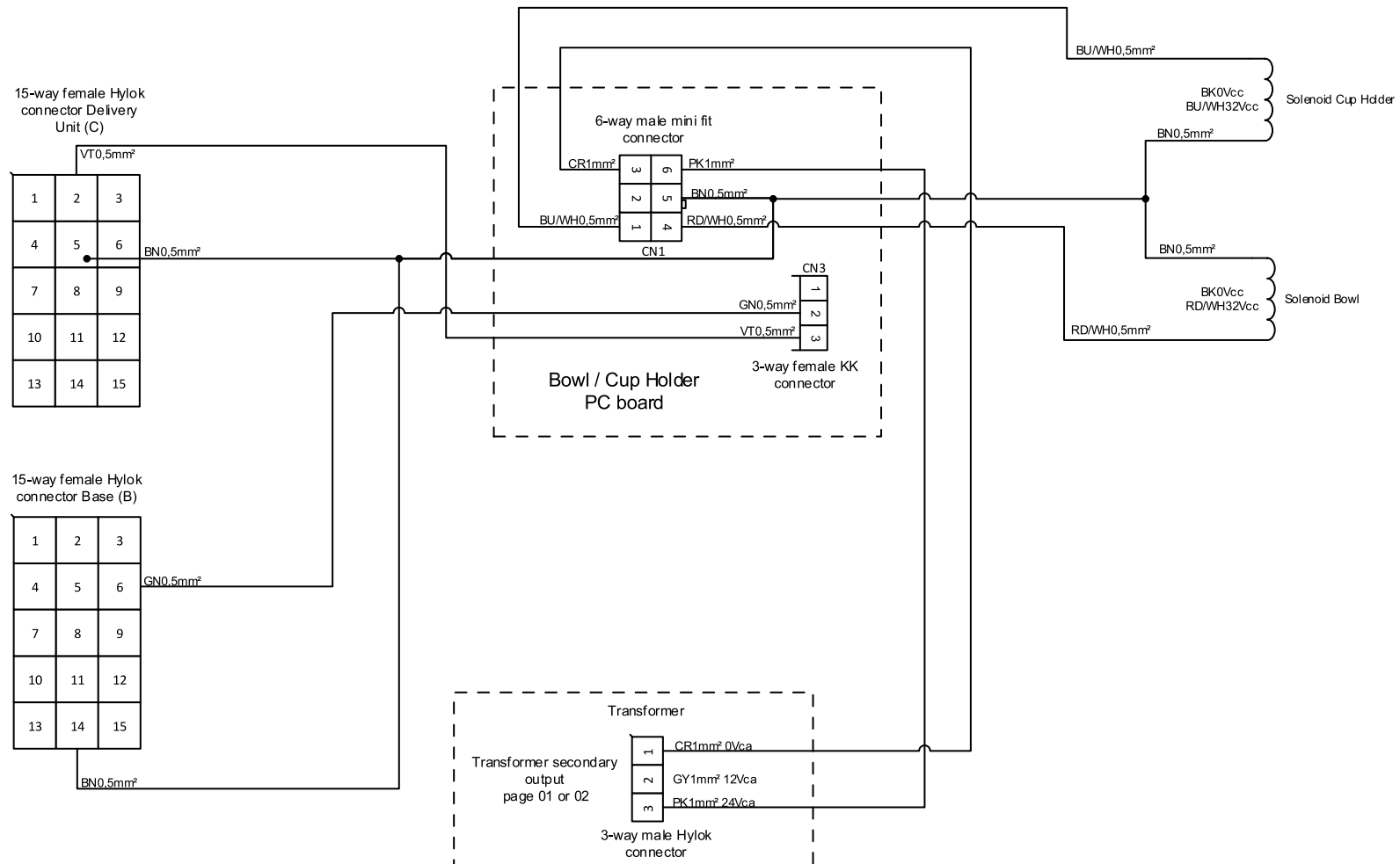

Color Legend	
Black	BK
Red	RD
Blue	BU
Green	GN
White	WH
Brown	BN
Violet	VT
Crystal	CR
Orange	OG
Yellow	YE
Pink	PK
Grey	GY
Green/Yellow	GN/YE
Blue/White	BU/WH
Red/White	RD/WH

Connection Bowl PC board, Cup Holder
 -Optional items according to the equipment configuration grid

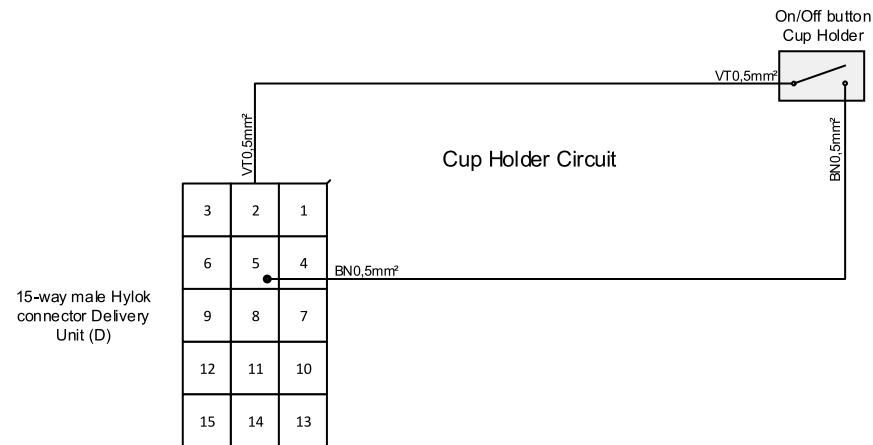

Color Legend	
Black	BK
Red	RD
Blue	BU
Green	GN
White	WH
Brown	BN
Violet	VT
Crystal	CR
Orange	OG
Yellow	YE
Pink	PK
Grey	GY
Green/Yellow	GN/YE
Blue/White	BU/WH
Red/White	RD/WH

Solenoid Bowl and Cup Holder connection on the equipment
 -Optional items according to the equipment configuration grid

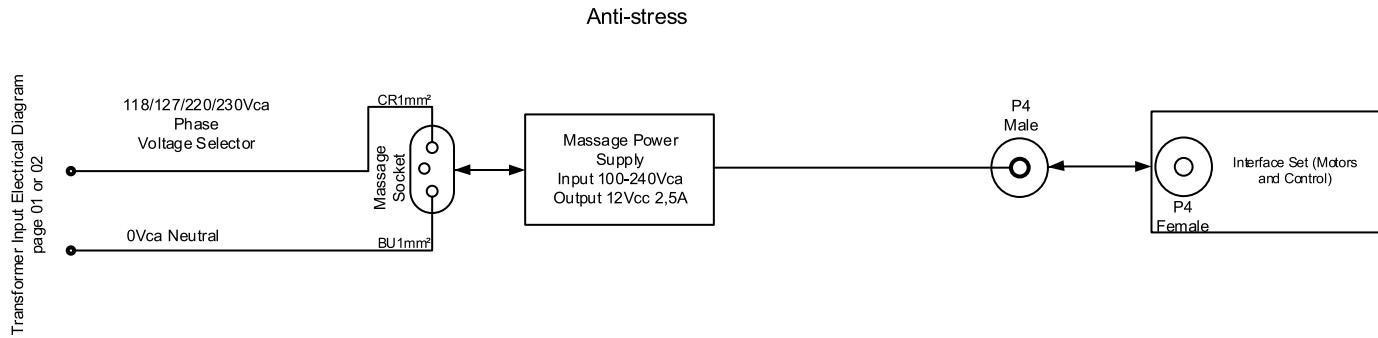

Transformer Input Electrical Diagram page 01 or 02

Color Legend	
Black	BK
Red	RD
Blue	BU
Green	GN
White	WH
Brown	BN
Violet	VT
Crystal	CR
Orange	OG
Yellow	YE
Pink	PK
Grey	GY
Green/Yellow	GN/YE
Blue/White	BU/WH
Red/White	RD/WH

Anti-stress connection
 -Optional items according to the equipment configuration grid

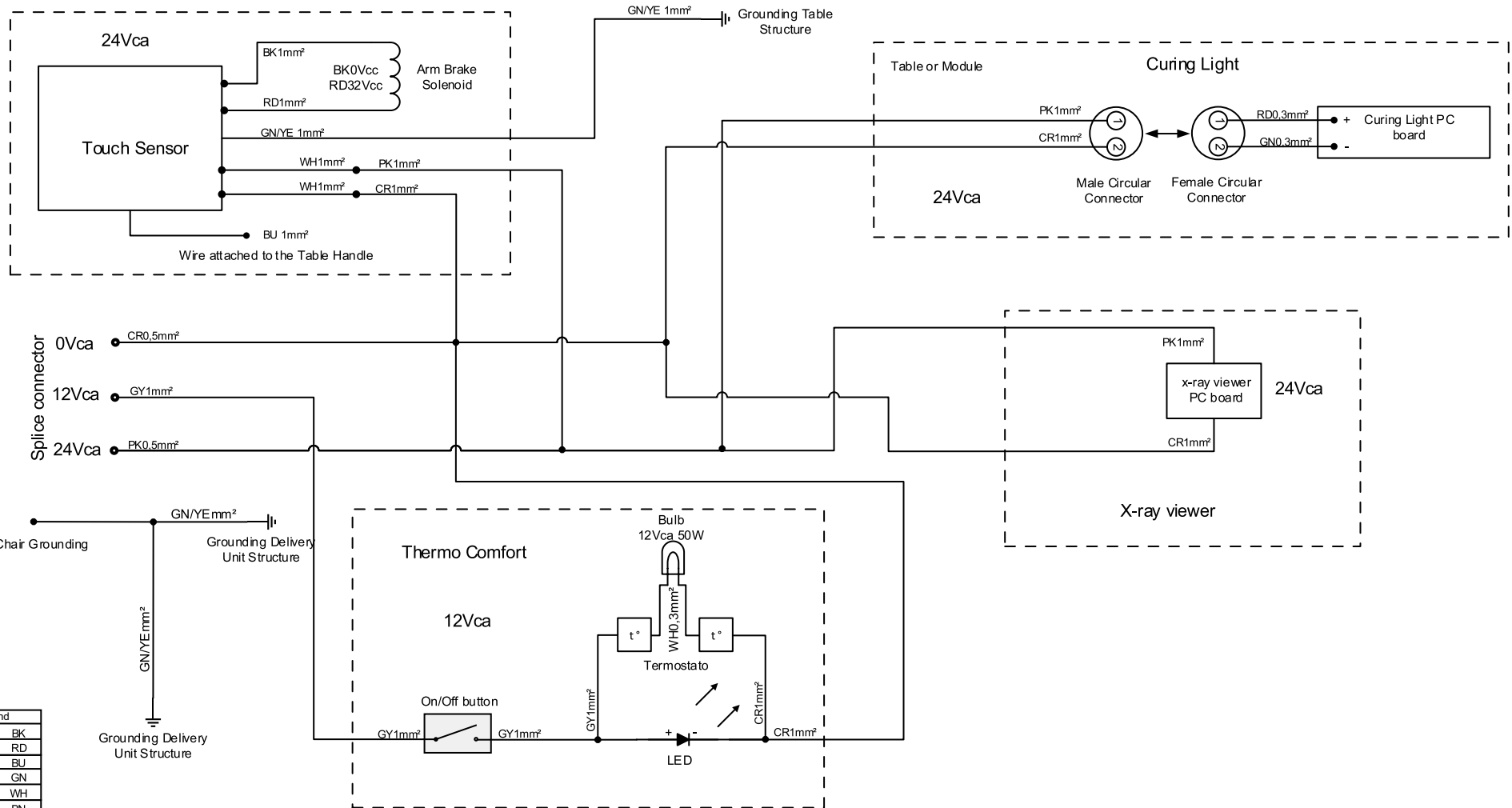

Color Legend	
Black	BK
Red	RD
Blue	BU
Green	GN
White	WH
Brown	BN
Violet	VT
Crystal	CR
Orange	OG
Yellow	YE
Pink	PK
Grey	GY
Green/Yellow	GN/YE
Blue/White	BU/WH
Red/White	RD/WH

Touch sensor connection, Photopolymerizer, X-Ray Viewer and Thermo Comfort -Optional items according to the equipment configuration grid

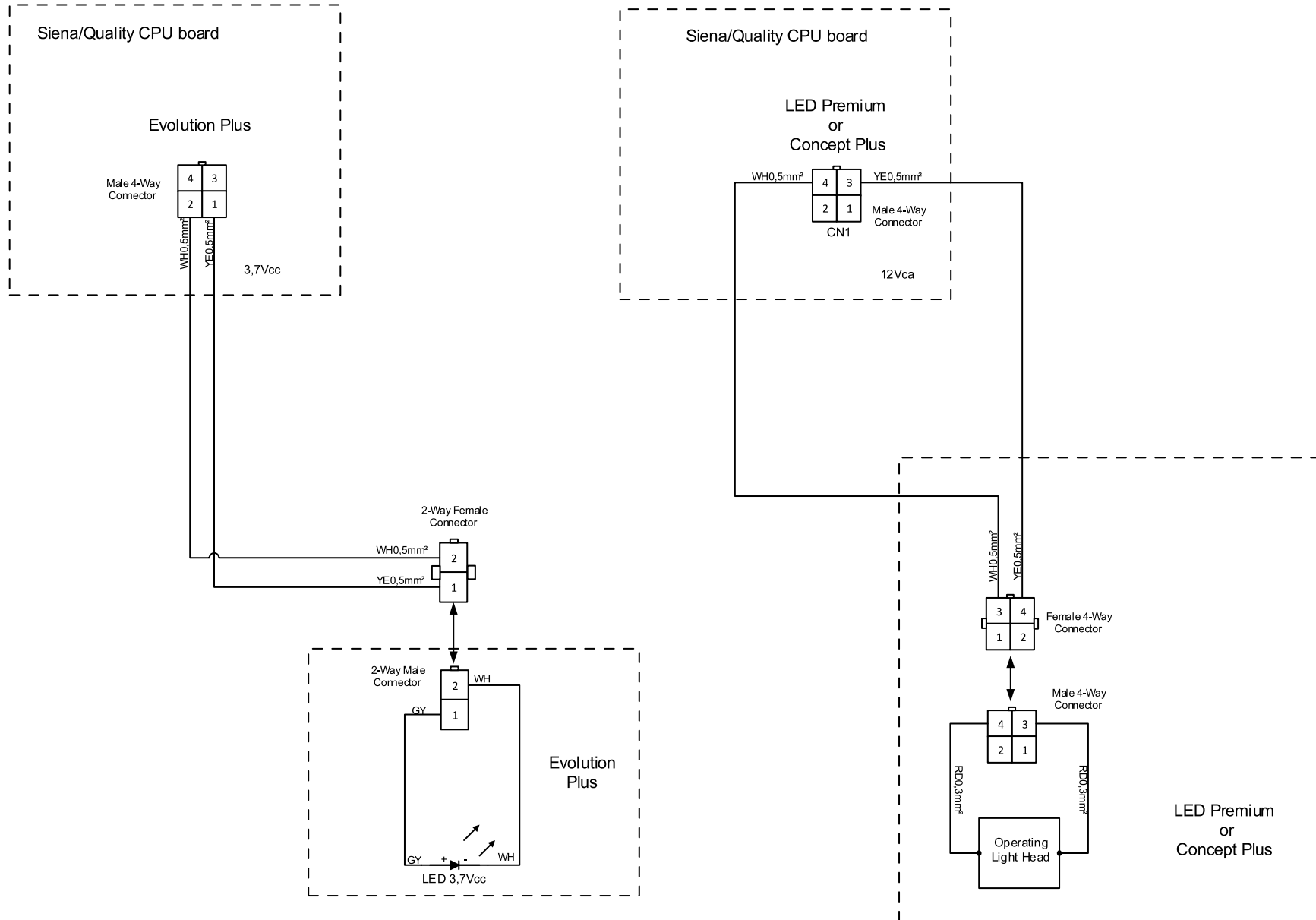

Color Legend	
Black	BK
Red	RD
Blue	BU
Green	GN
White	WH
Brown	BN
Violet	VT
Crystal	CR
Orange	OG
Yellow	YE
Pink	PK
Grey	GY
Green/Yellow	GN/YE
Blue/White	BU/WH
Red/White	RD/WH

Connection Operating Light
 -Optional items according to the equipment configuration grid

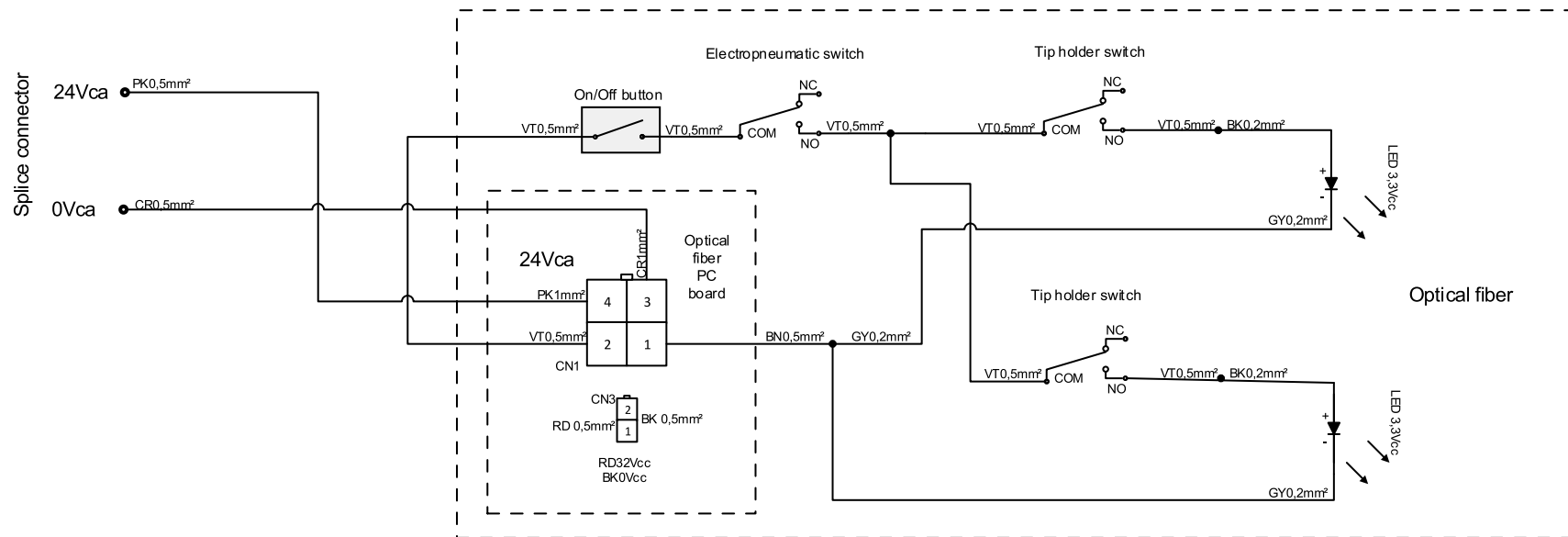

Color Legend	
Black	BK
Red	RD
Blue	BU
Green	GN
White	WH
Brown	BN
Violet	VT
Crystal	CR
Orange	OG
Yellow	YE
Pink	PK
Grey	GY
Green/Yellow	GN/YE
Blue/White	BU/WH
Red/White	RD/WH

Connection with Two Optical Fiber-Optional items according to the equipment configuration grid
 -With Air-Jet only, use a CN3 PC Fiber Optic output board
 -If Optical fiber and Air-Jet requested, do not use the Optical fiber On/Off button

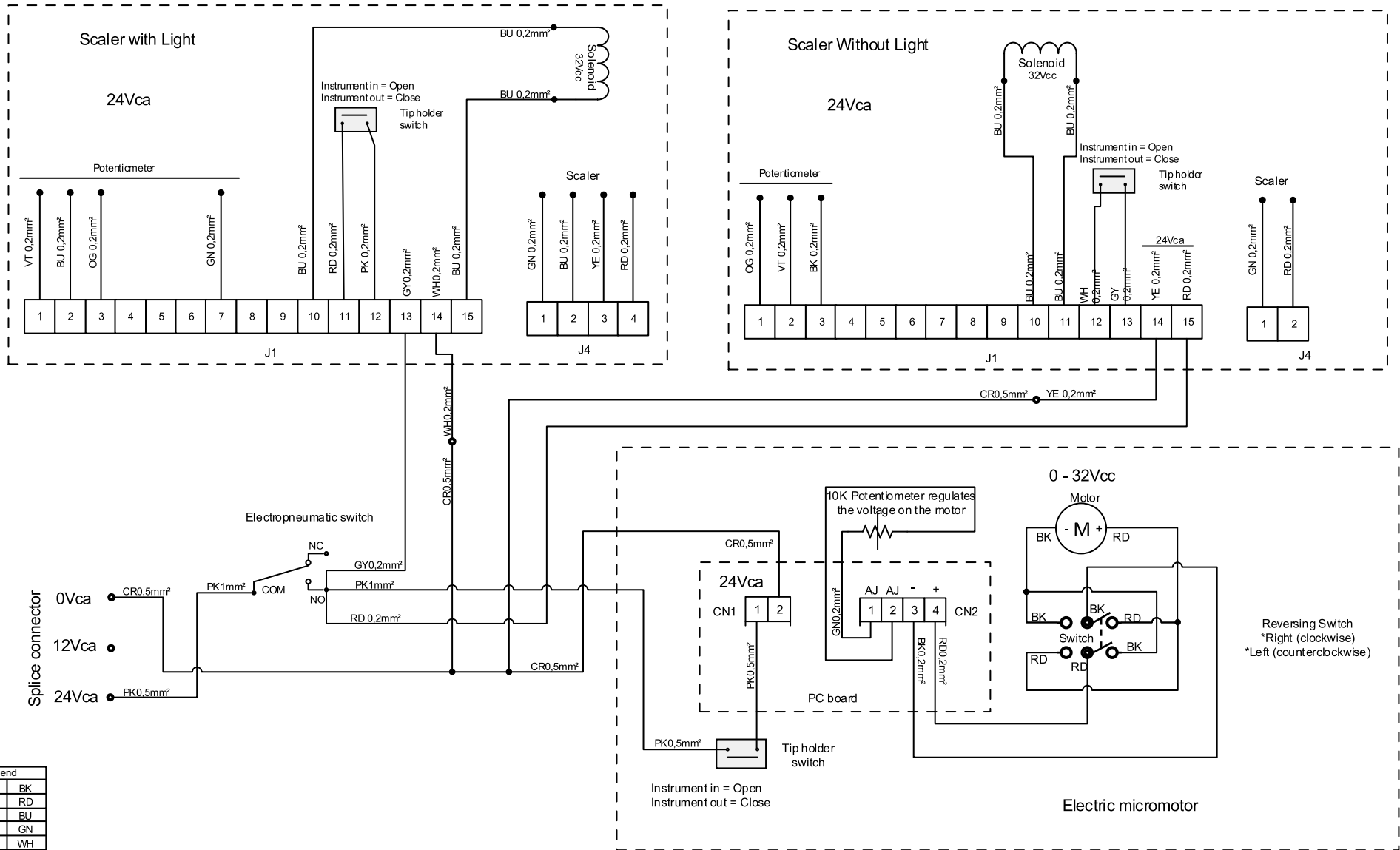

Color Legend	
Black	BK
Red	RD
Blue	BU
Green	GN
White	WH
Brown	BN
Violet	VT
Crystal	CR
Orange	OG
Yellow	YE
Pink	PK
Grey	GY
Green/Yellow	GN/YE
Blue/White	BU/WH
Red/White	RD/WH

Scaler and Electrical Micromotor Connection
 -Optional items according to the equipment configuration grid

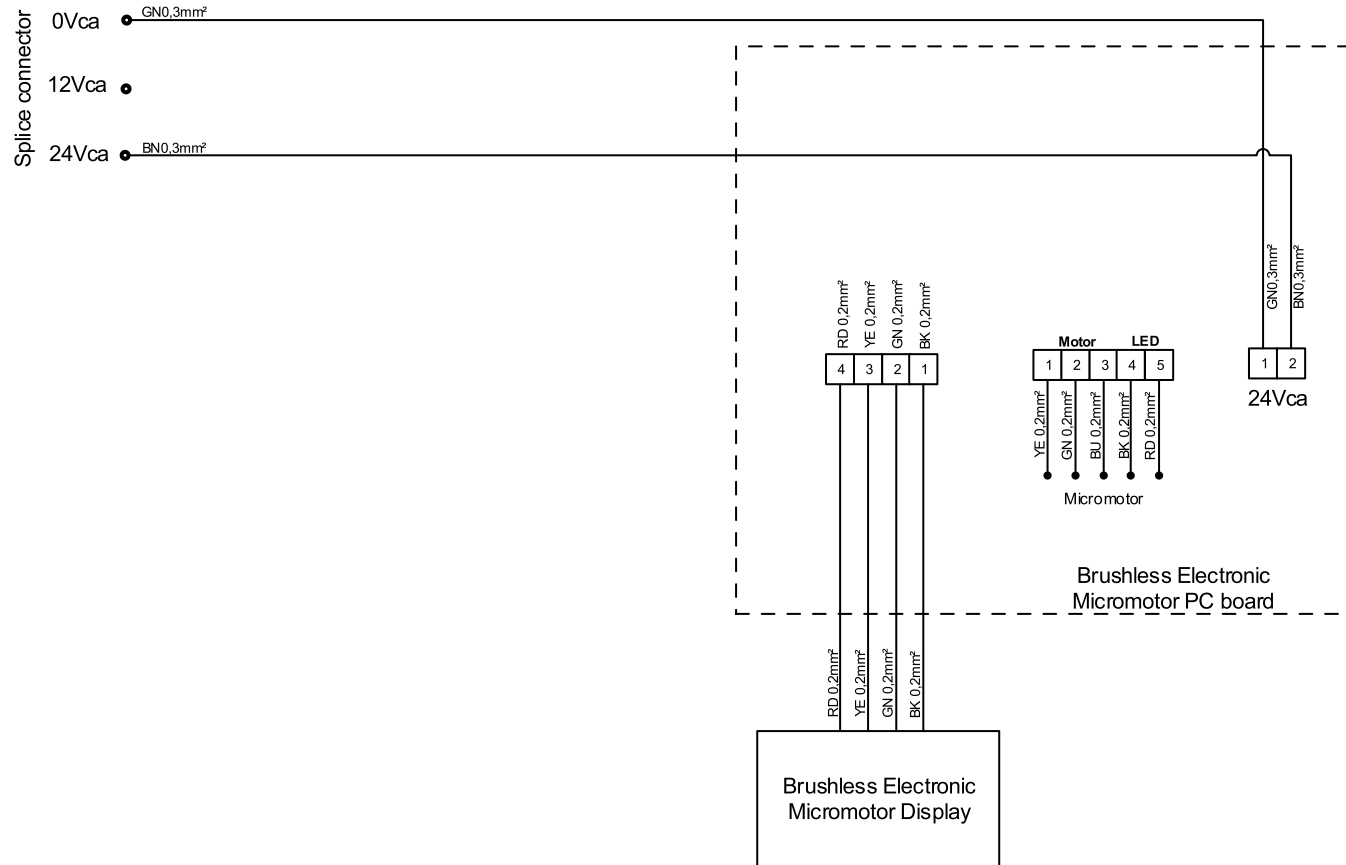

Color Legend	
Black	BK
Red	RD
Blue	BU
Green	GN
White	WH
Brown	BN
Violet	VT
Crystal	CR
Orange	OG
Yellow	YE
Pink	PK
Grey	GY
Green/Yellow	GN/YE
Blue/White	BU/WH
Red/White	RD/WH

Brushless electronic micromotor connection
 -Optional items according to the equipment configuration grid

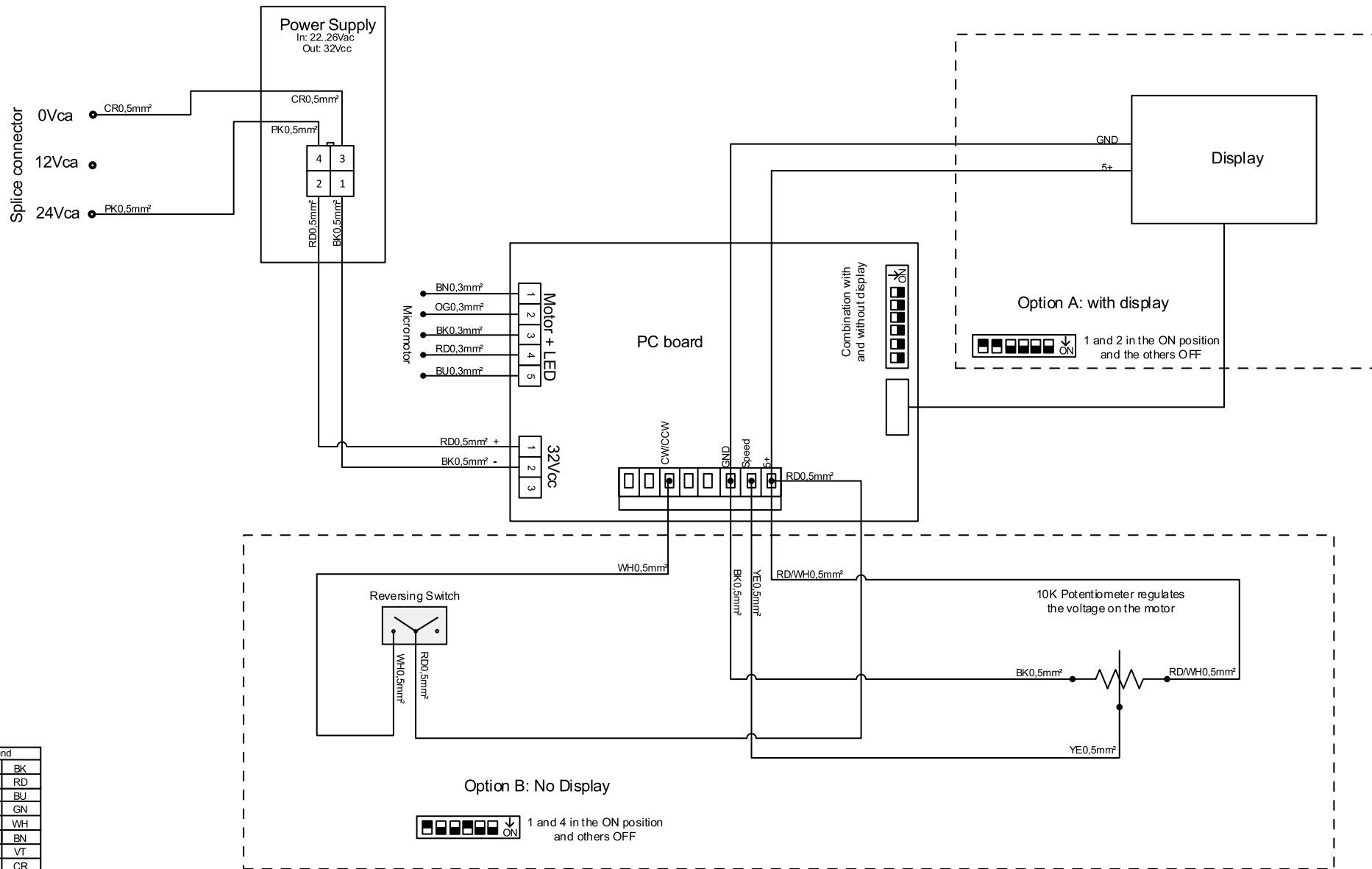

Color Legend	
Black	BK
Red	RD
Blue	BU
Green	GN
White	WH
Brown	BN
Violet	VT
Crystal	CR
Orange	OG
Yellow	YE
Pink	PK
Grey	GY
Green/Yellow	GN/YE
Blue/White	BU/WH
Red/White	RD/WH

Micromotor Bien Air connection
 -Optional items according to the equipment configuration grid

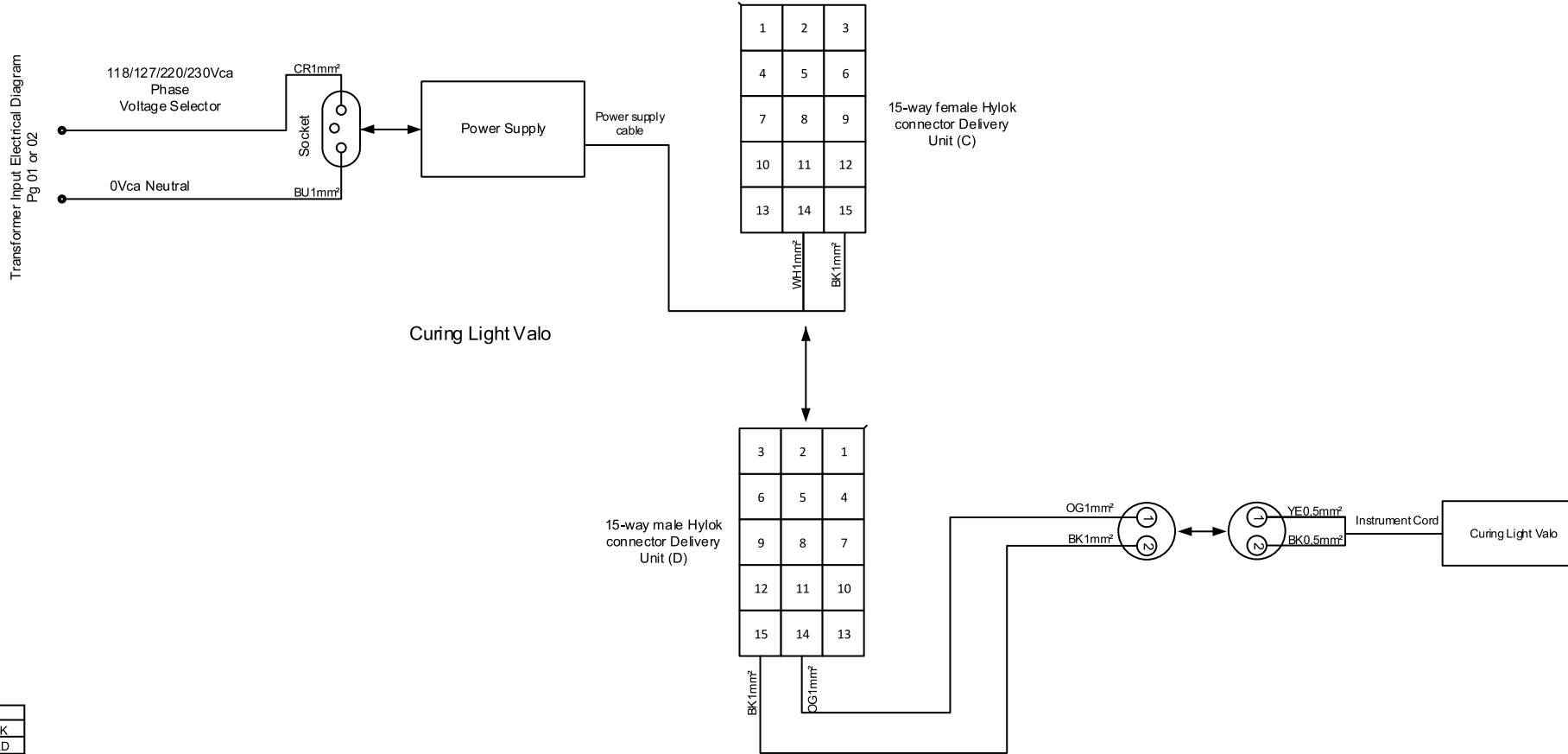

Transformer Input Electrical Diagram
Pg 01 or 02

Curing Light Valo

15-way female Hylok
connector Delivery
Unit (C)

15-way male Hylok
connector Delivery
Unit (D)

Curing Light Valo

Color Legend	
Black	BK
Red	RD
Blue	BU
Green	GN
White	WH
Brown	BN
Violet	VT
Crystal	CR
Orange	OG
Yellow	YE
Pink	PK
Grey	GY
Green/Yellow	GN/YE
Blue/White	BU/WH
Red/White	RD/WH

Curing Light Valo Connection
-Optional items according to the equipment configuration grid

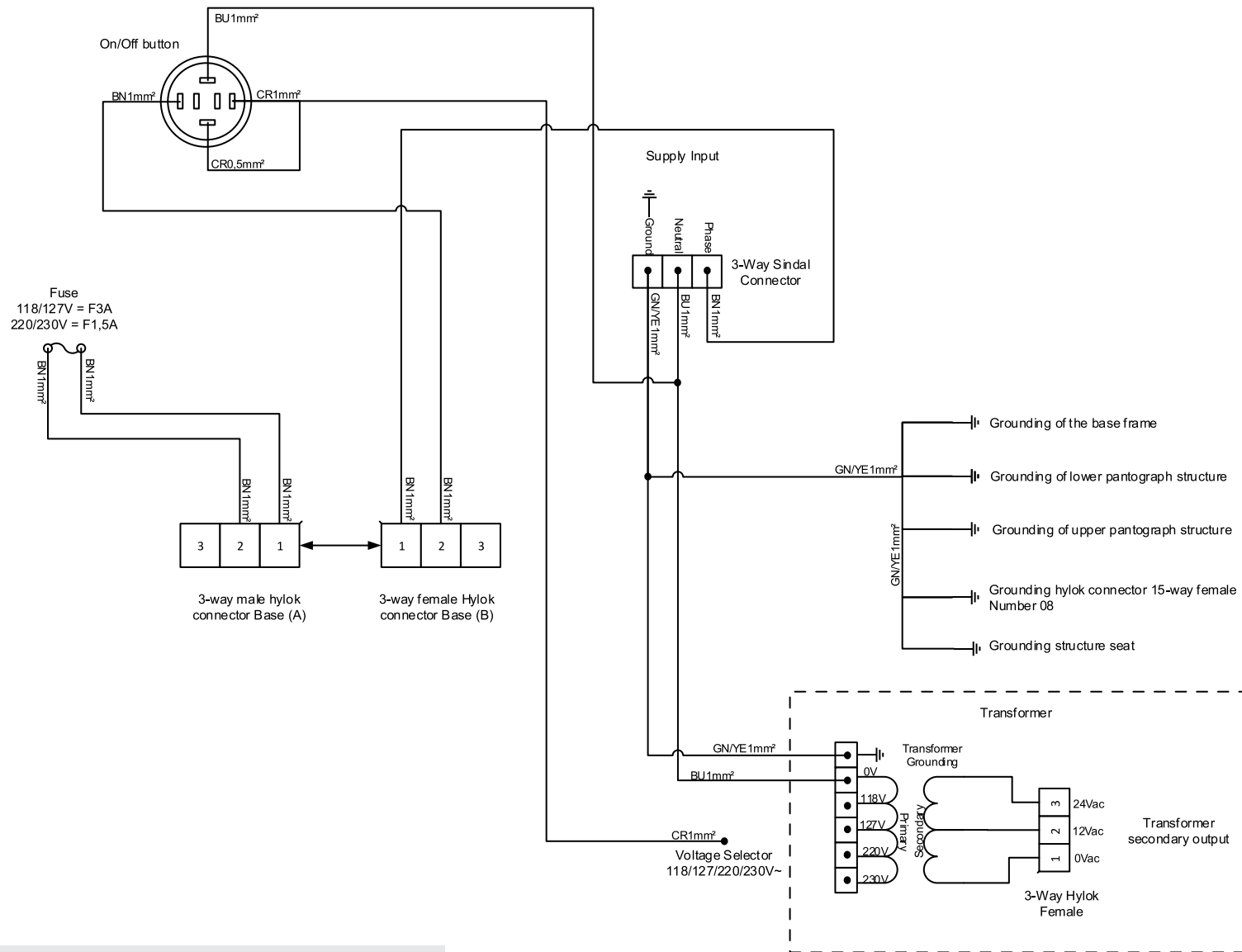

Color Legend	
Black	BK
Red	RD
Blue	BU
Green	GN
White	WH
Brown	BN
Violet	VT
Crystal	CR
Orange	OG
Yellow	YE
Pink	PK
Grey	GY
Green/Yellow	GN/YE
Blue/White	BU/WH
Red/White	RD/WH

Chair
 -Electrical part + Grounding
 -Optional items according to the equipment configuration grid

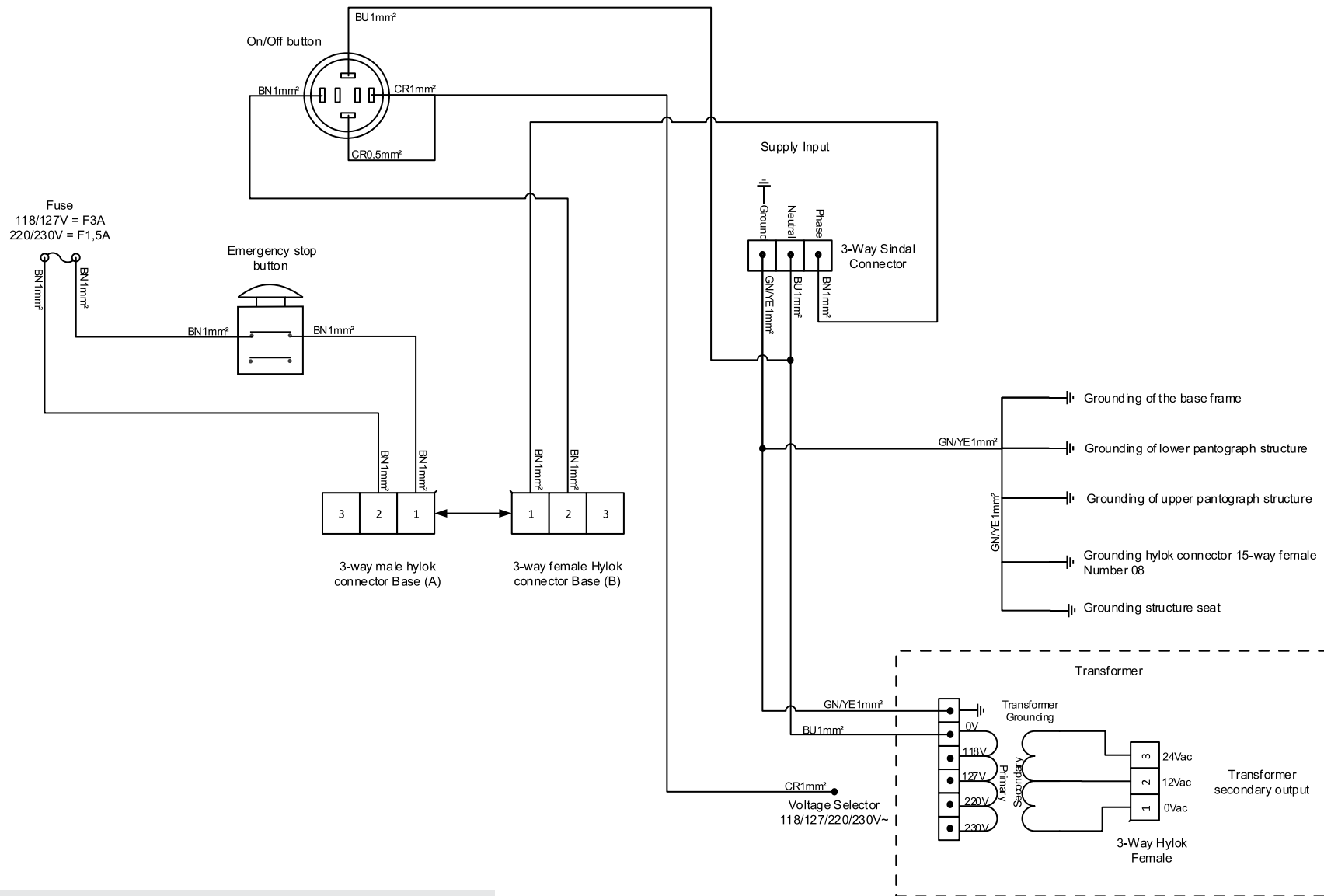

Color Legend	
Black	BK
Red	RD
Blue	BU
Green	GN
White	WH
Brown	BN
Violet	VT
Crystal	CR
Orange	OG
Yellow	YE
Pink	PK
Grey	GY
Green/Yellow	GN/YE
Blue/White	BU/WH
Red/White	RD/WH

Chair
 -Electric part + Grounding + Emergency stop button
 -Optional items according to the equipment configuration grid

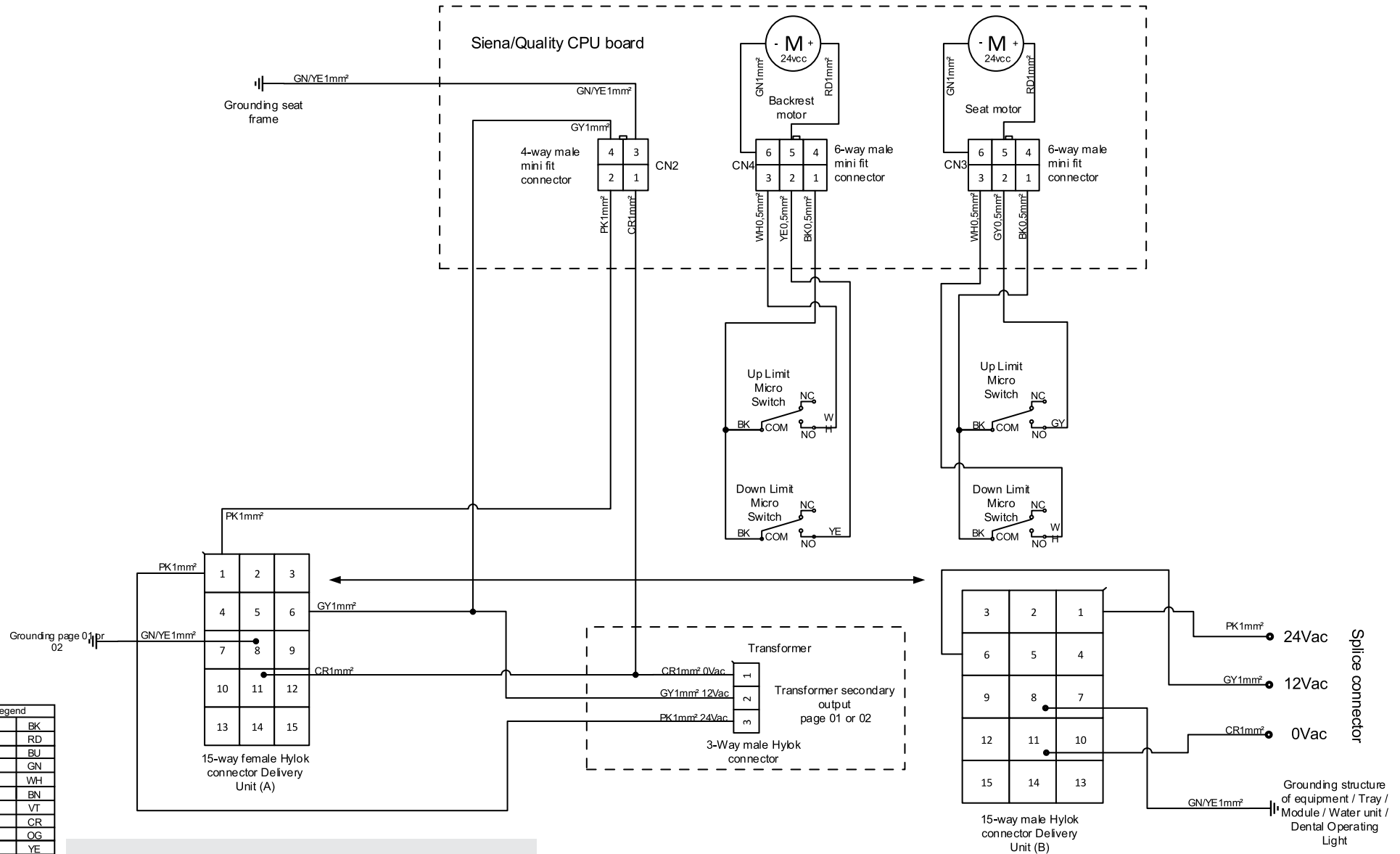

Color Legend	
Black	BK
Red	RD
Blue	BU
Green	GN
White	WH
Brown	BN
Violet	VT
Crystal	CR
Orange	OG
Yellow	YE
Pink	PK
Grey	GY
Green/Yellow	GN/YE
Blue/White	BU/WH
Red/White	RD/WH

CPU PC board and motors connection
-Optional items according to the equipment configuration grid

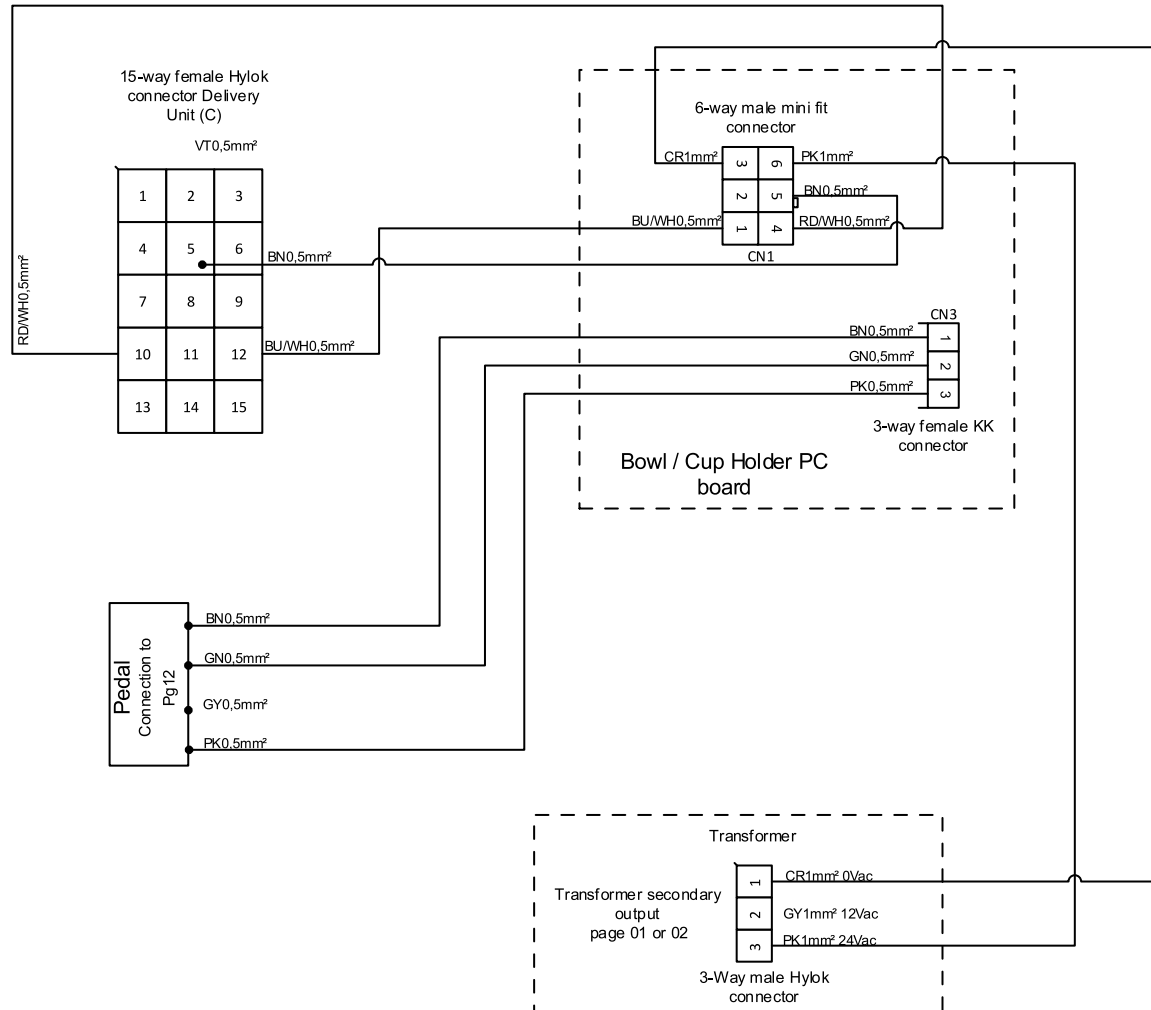

Color Legend	
Black	BK
Red	RD
Blue	BU
Green	GN
White	WH
Brown	BN
Violet	VT
Crystal	CR
Orange	OG
Yellow	YE
Pink	PK
Grey	GY
Green/Yellow	GN/YE
Blue/White	BU/WH
Red/White	RD/WH

Connection Bowl PC board and Cup Holder
-Optional items according to the equipment configuration grid

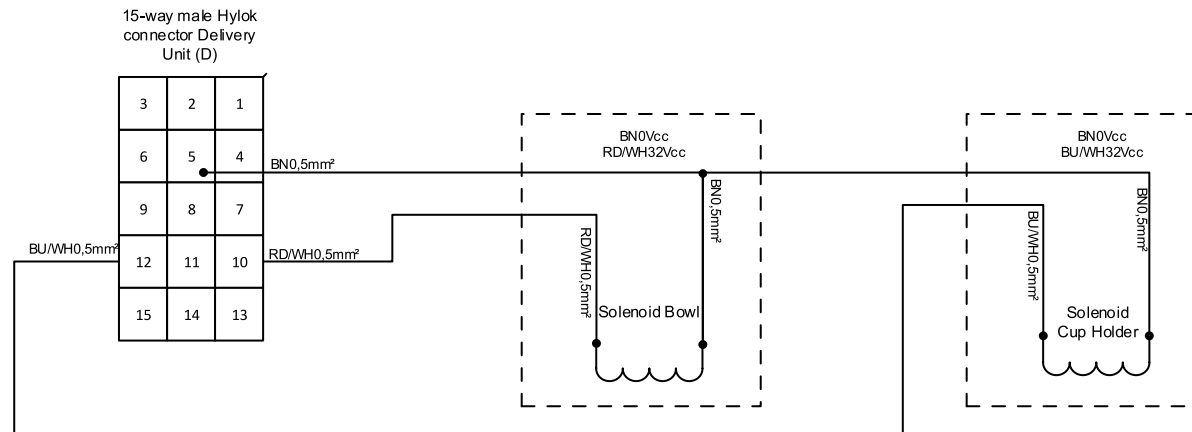

Color Legend	
Black	BK
Red	RD
Blue	BU
Green	GN
White	WH
Brown	BN
Violet	VT
Crystal	CR
Orange	OG
Yellow	YE
Pink	PK
Grey	GY
Green/Yellow	GN/YE
Blue/White	BU/WH
Red/White	RD/WH

Connection Solenoids Bowl and Cup Holder in the Delivery Unit
-Optional items according to the equipment configuration grid

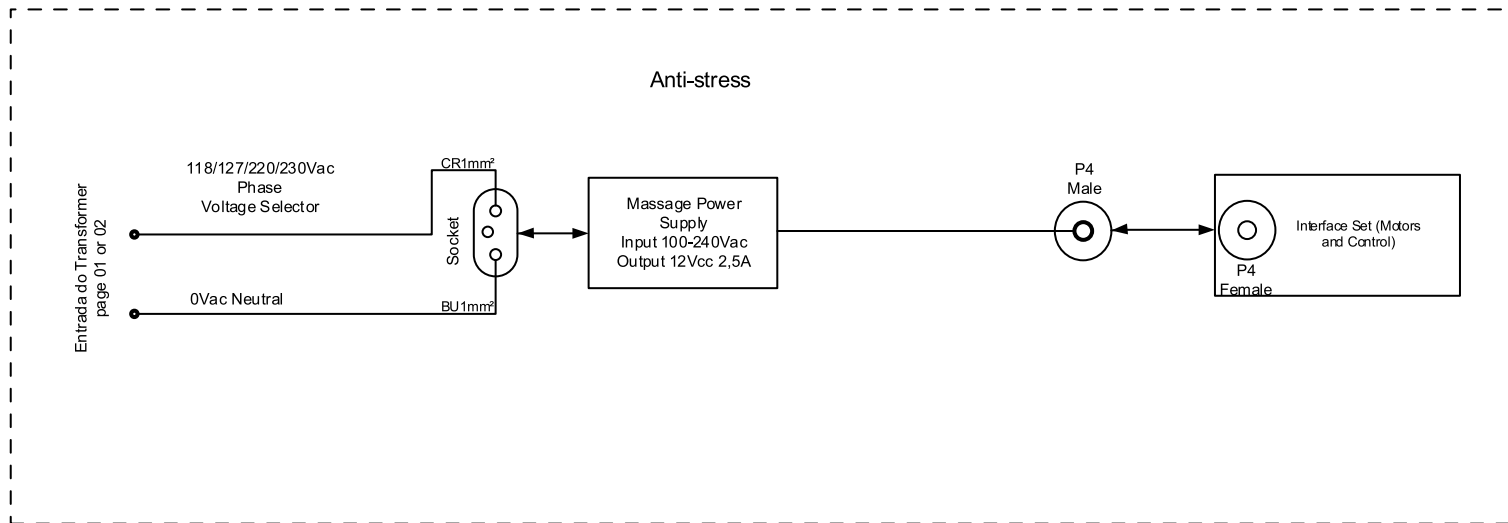

Color Legend	
Black	BK
Red	RD
Blue	BU
Green	GN
White	WH
Brown	BN
Violet	VT
Crystal	CR
Orange	OG
Yellow	YE
Pink	PK
Grey	GY
Green/Yellow	GN/YE
Blue/White	BU/WH
Red/White	RD/WH

Anti-Stress Connection
 -Optional items according to the equipment configuration grid

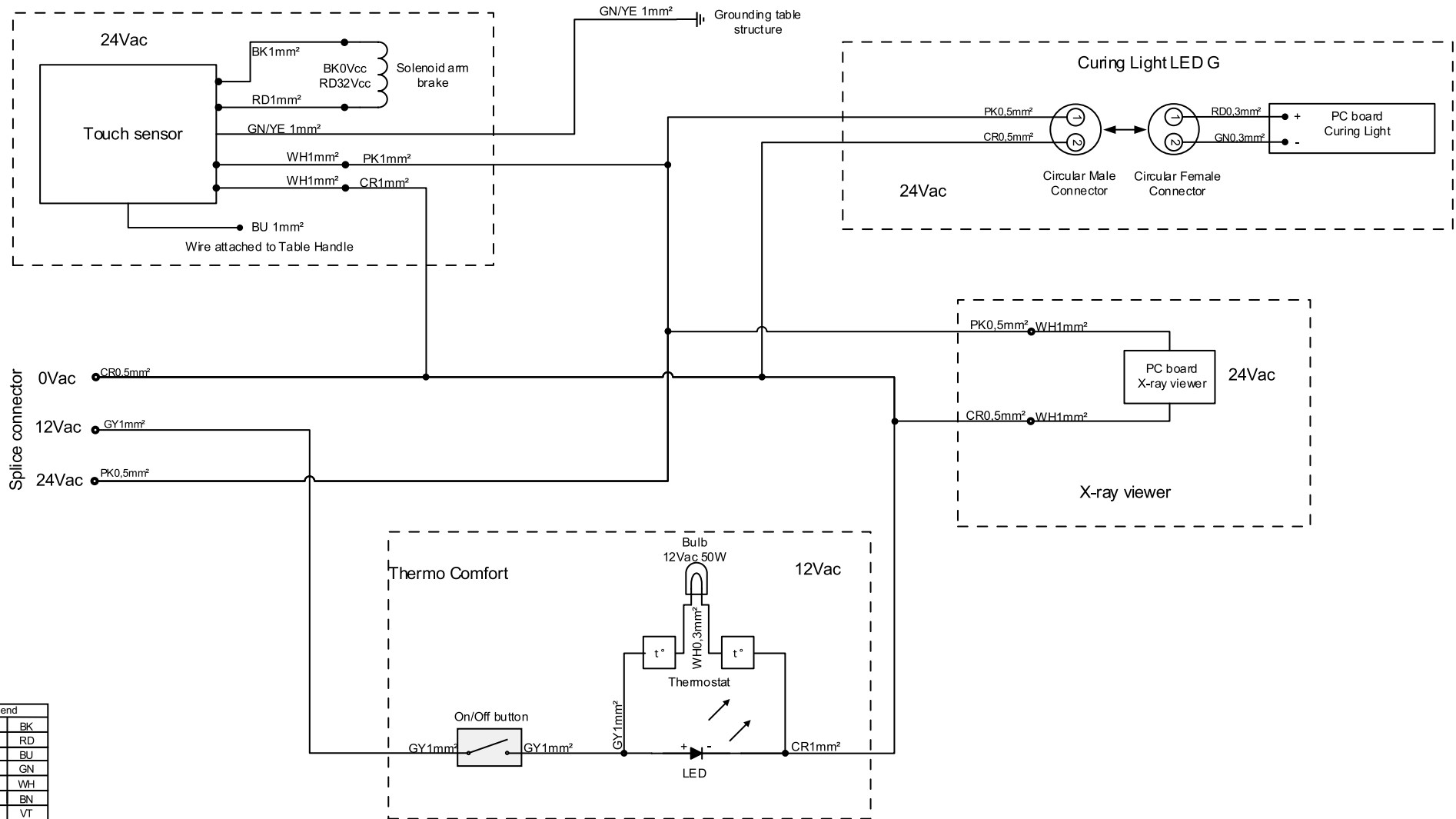

Color Legend	
Black	BK
Red	RD
Blue	BU
Green	GN
White	WH
Brown	BN
Violet	VT
Crystal	CR
Orange	OG
Yellow	YE
Pink	PK
Grey	GY
Green/Yellow	GN/YE
Blue/White	BU/WH
Red/White	RD/WH

Touch switch-on sensor, curing light, X-ray viewer and Thermo Comfort
 -Optional items according to the equipment configuration grid

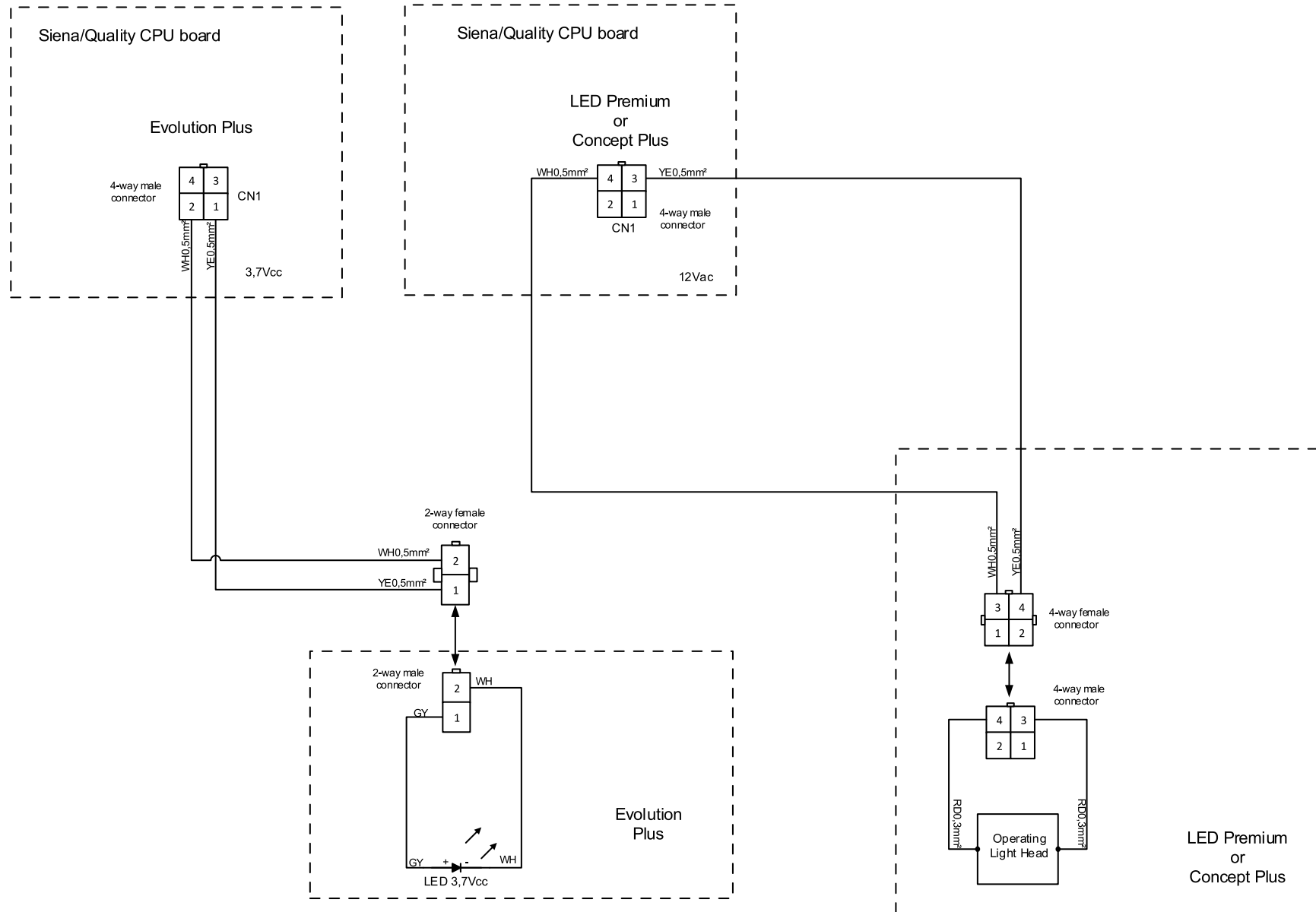

Color Legend	
Black	BK
Red	RD
Blue	BU
Green	GN
White	WH
Brown	BN
Violet	VT
Crystal	CR
Orange	OG
Yellow	YE
Pink	PK
Grey	GY
Green/Yellow	GN/YE
Blue/White	BU/WH
Red/White	RD/WH

Operating Light
 -Optional items according to the equipment configuration grid

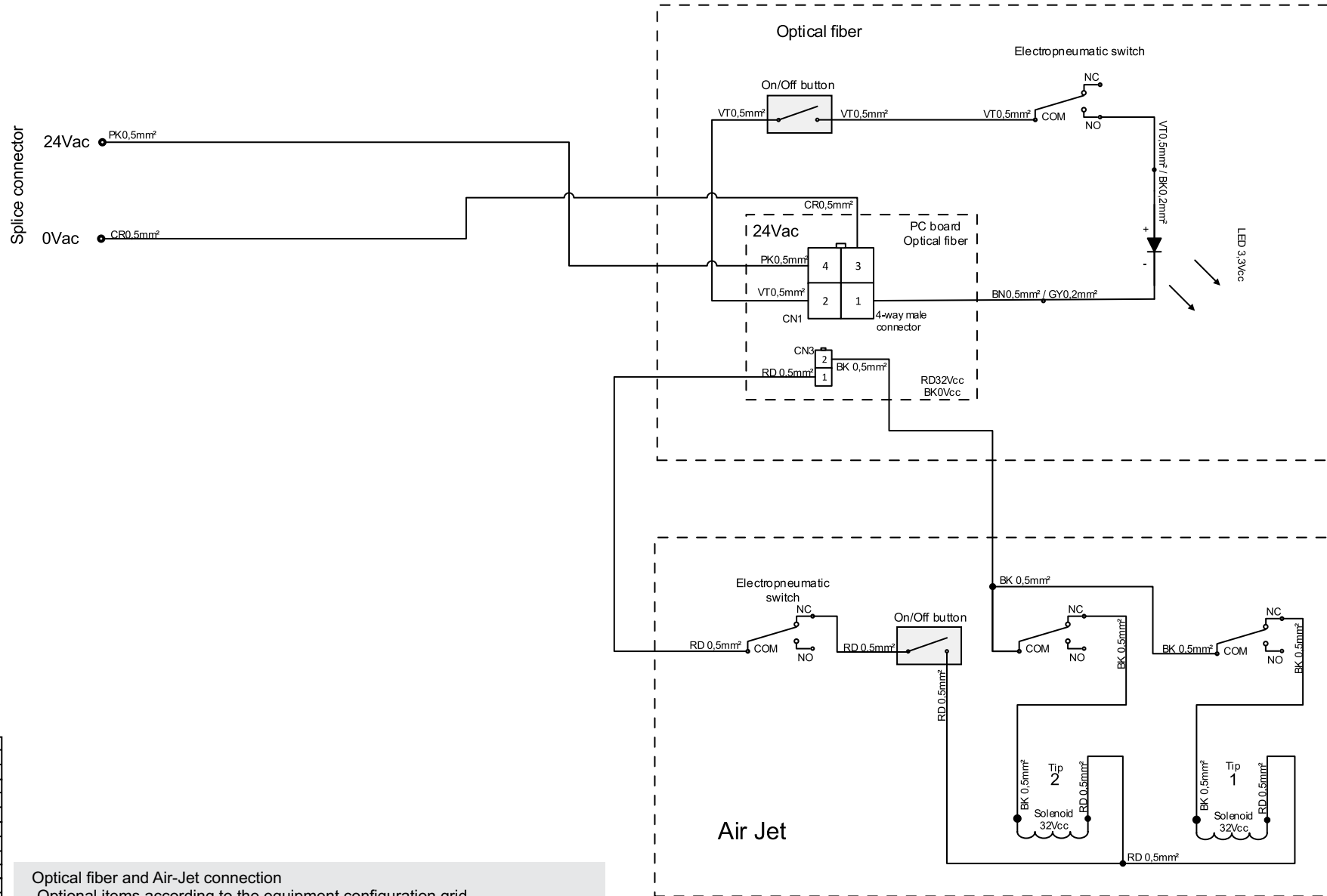

Color Legend	
Black	BK
Red	RD
Blue	BU
Green	GN
White	WH
Brown	BN
Violet	VT
Crystal	CR
Orange	OG
Yellow	YE
Pink	PK
Grey	GY
Green/Yellow	GN/YE
Blue/White	BU/WH
Red/White	RD/WH

Optical fiber and Air-Jet connection
 -Optional items according to the equipment configuration grid
 -Only with Air-Jet, use a PC Optical fiber CN3 output board.
 -If Optical fiber and Air-Jet are requested, do not use the On/Off button of Optical fiber

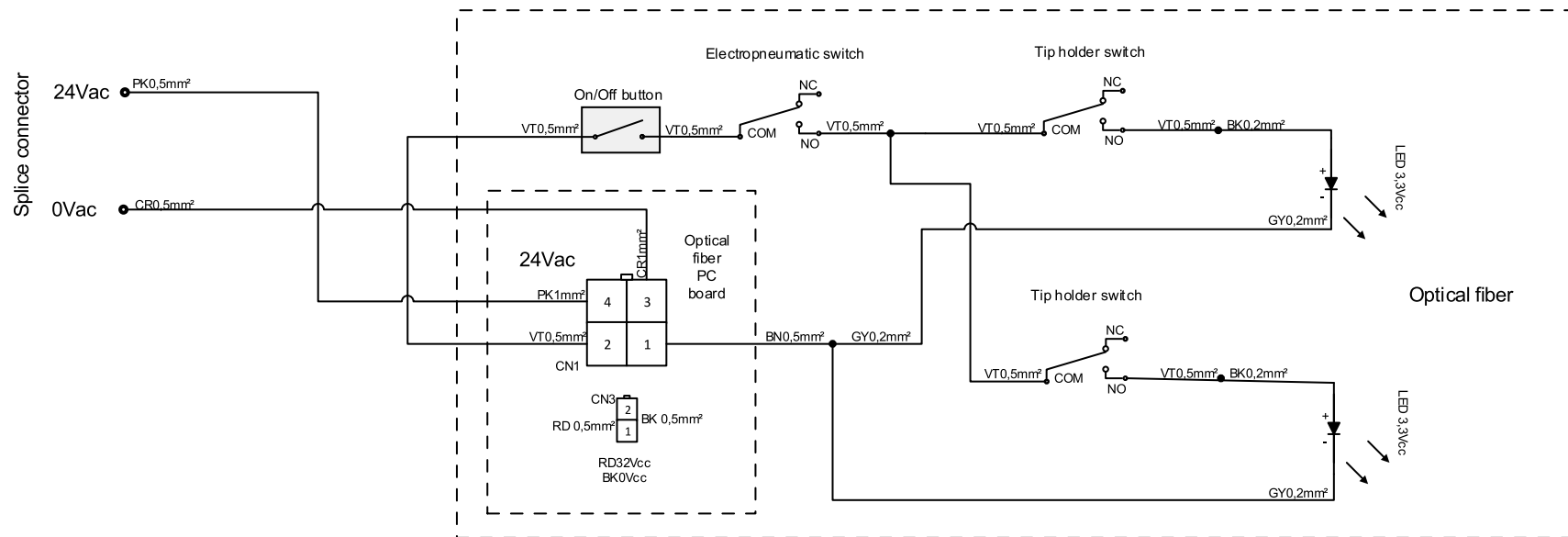

Color Legend	
Black	BK
Red	RD
Blue	BU
Green	GN
White	WH
Brown	BN
Violet	VT
Crystal	CR
Orange	OG
Yellow	YE
Pink	PK
Grey	GY
Green/Yellow	GN/YE
Blue/White	BU/WH
Red/White	RD/WH

Connection with Two Optical Fiber
 -Optional items according to the equipment configuration grid
 -With Air-Jet only, use a CN3 PC Fiber Optic output board.
 -If Optical fiber and Air-Jet requested, do not use the Optical fiber On/Off button

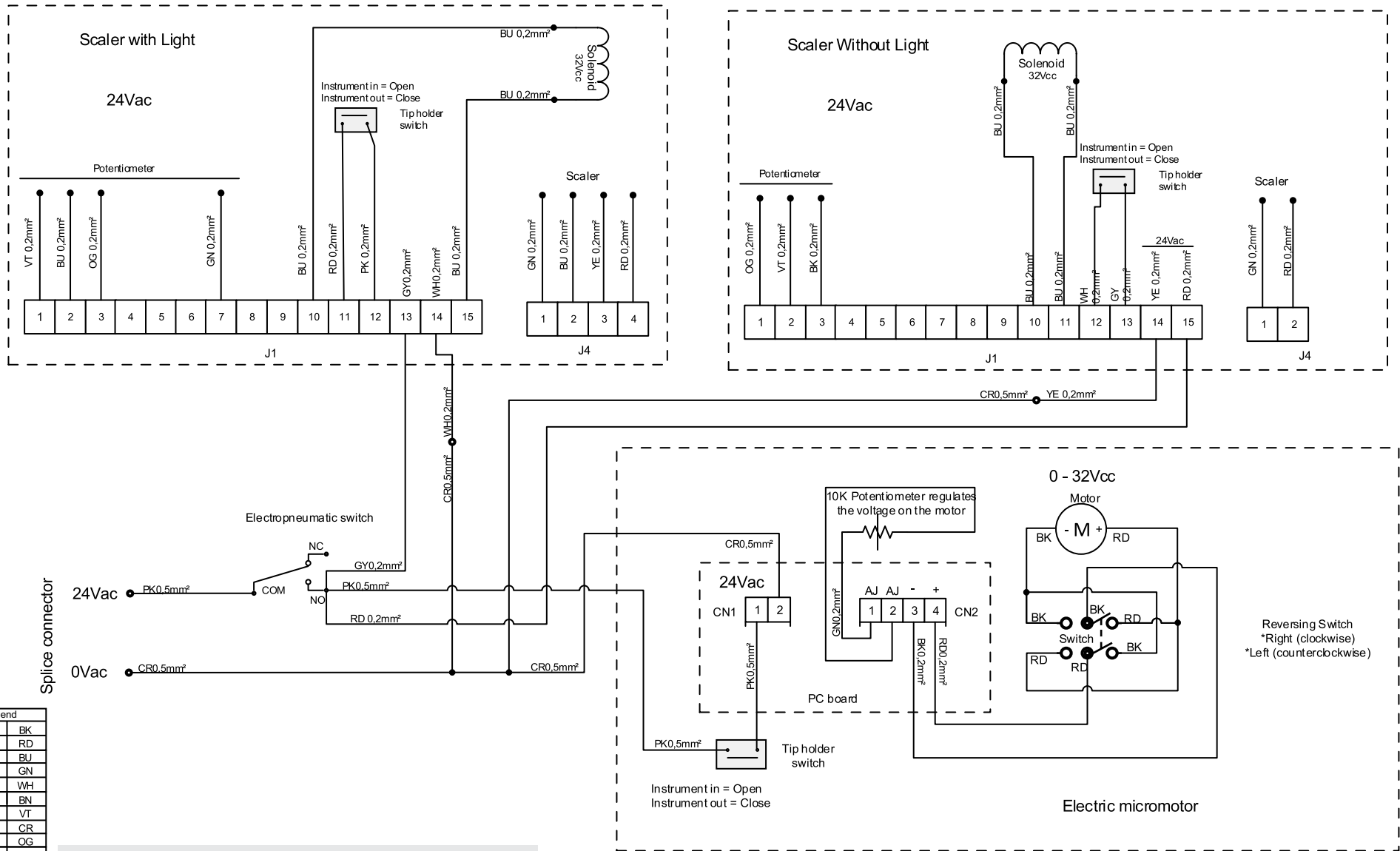

Color Legend	
Black	BK
Red	RD
Blue	BU
Green	GN
White	WH
Brown	BN
Violet	VT
Crystal	CR
Orange	OG
Yellow	YE
Pink	PK
Grey	GY
Green/Yellow	GN/YE
Blue/White	BU/WH
Red/White	RD/WH

Scaler and Electrical Micromotor Connection
-Optional items according to the equipment configuration grid

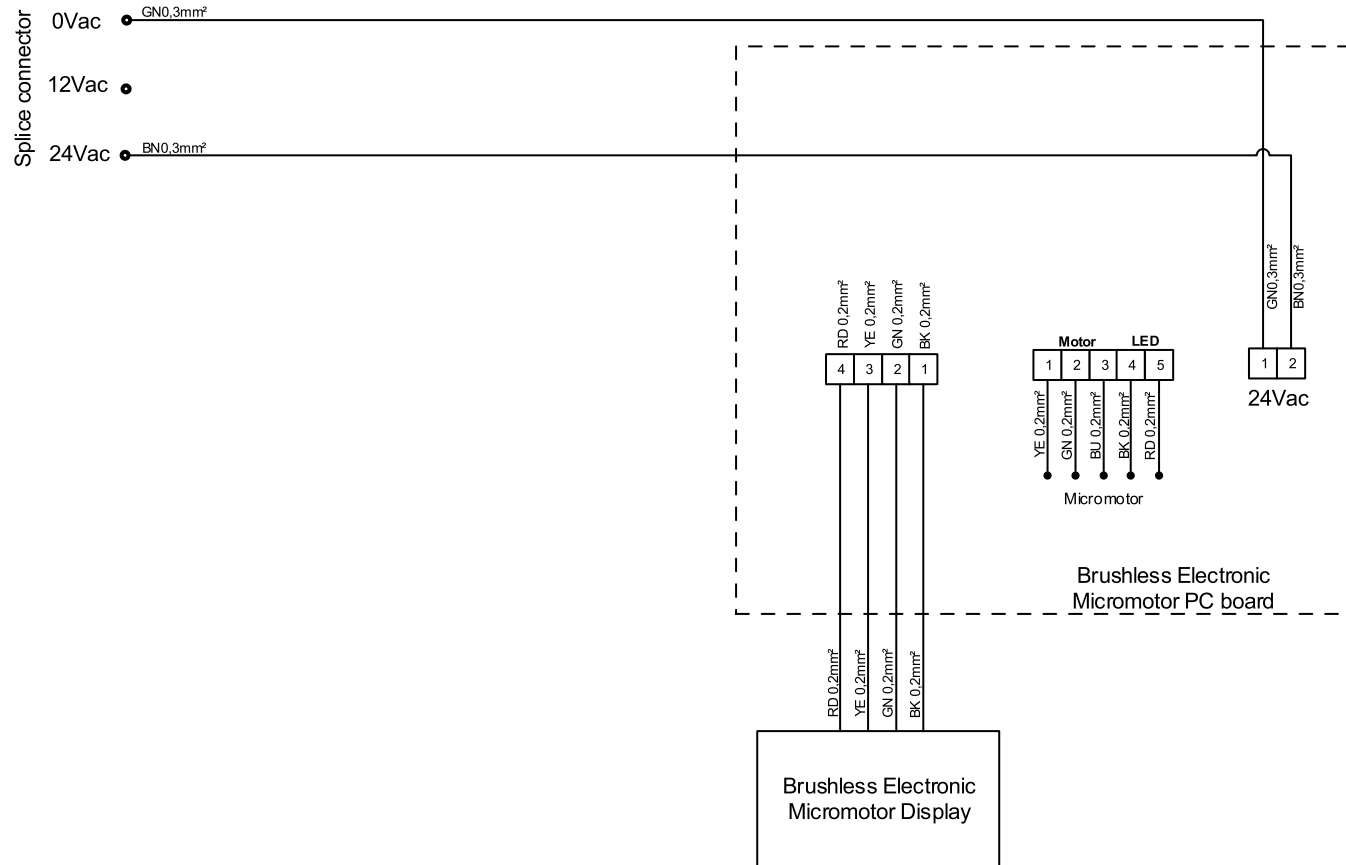

Color Legend	
Black	BK
Red	RD
Blue	BU
Green	GN
White	WH
Brown	BN
Violet	VT
Crystal	CR
Orange	OG
Yellow	YE
Pink	PK
Grey	GY
Green/Yellow	GN/YE
Blue/White	BU/WH
Red/White	RD/WH

Brushless electronic micromotor connection
 -Optional items according to the equipment configuration grid

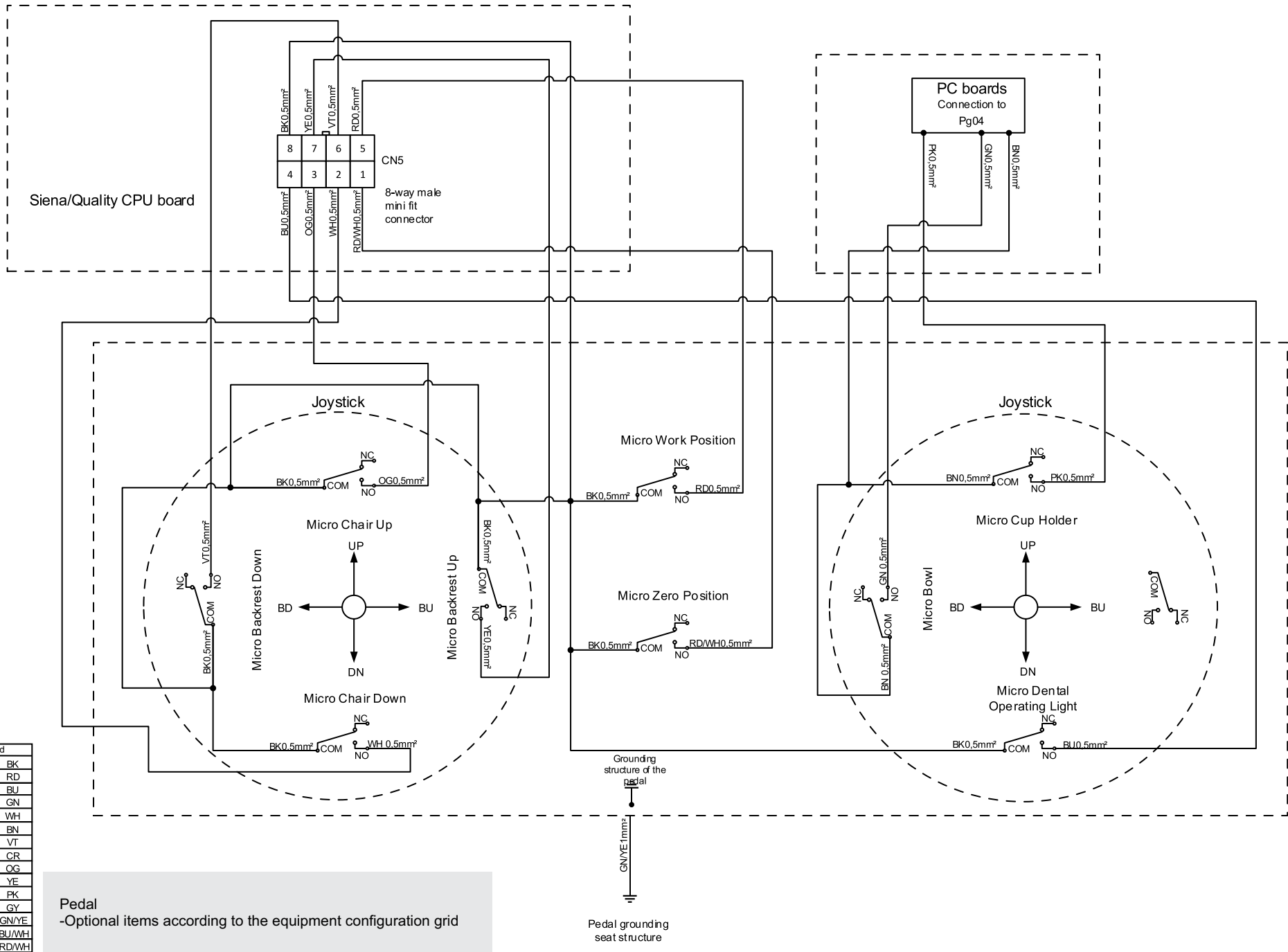

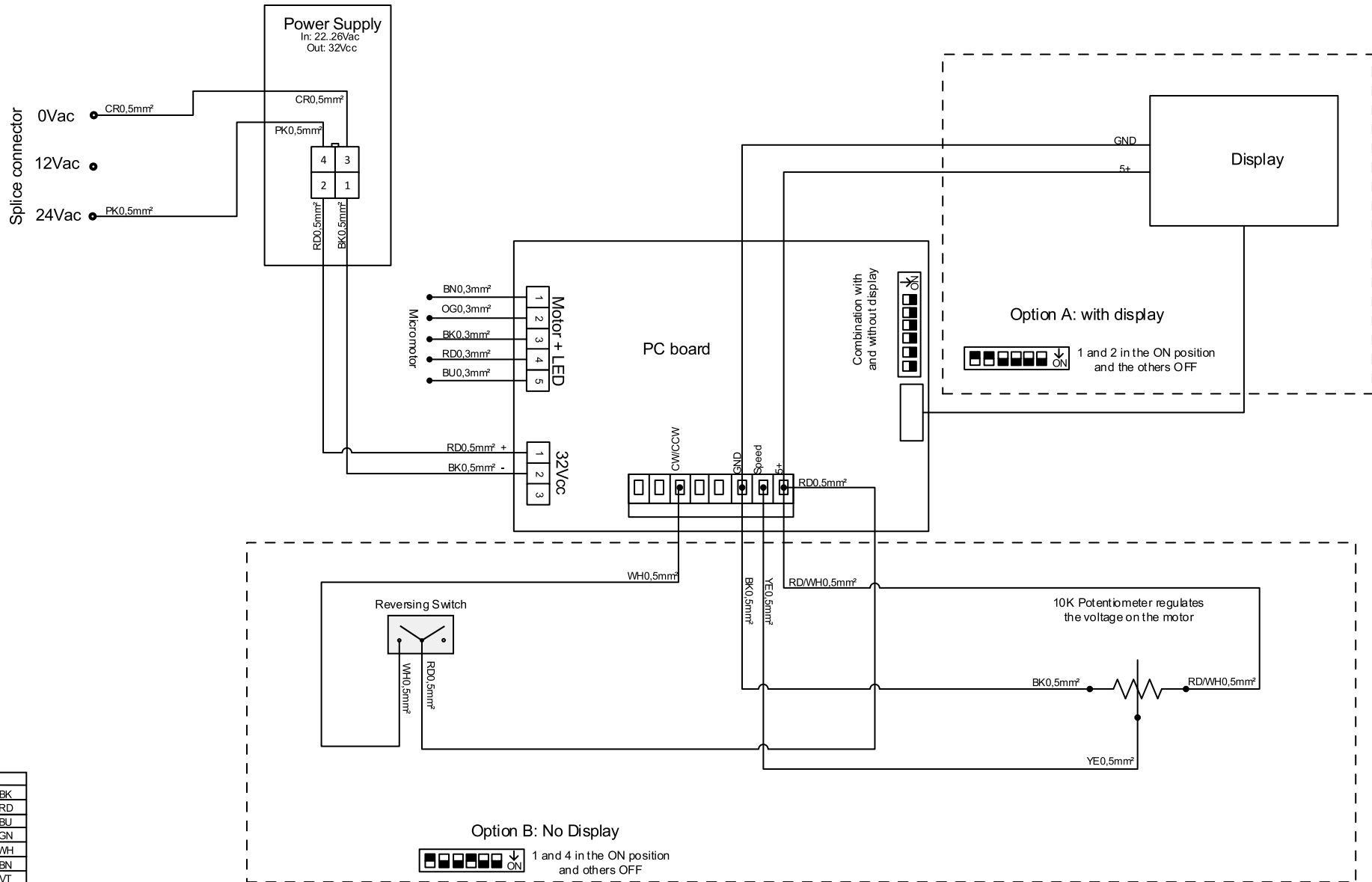

Color Legend	
Black	BK
Red	RD
Blue	BU
Green	GN
White	WH
Brown	BN
Violet	VT
Crystal	CR
Orange	OG
Yellow	YE
Pink	PK
Grey	GY
Green/Yellow	GN/YE
Blue/White	BU/WH
Red/White	RD/WH

Micromotor connection Bien Air
 -Optional items according to the equipment configuration grid

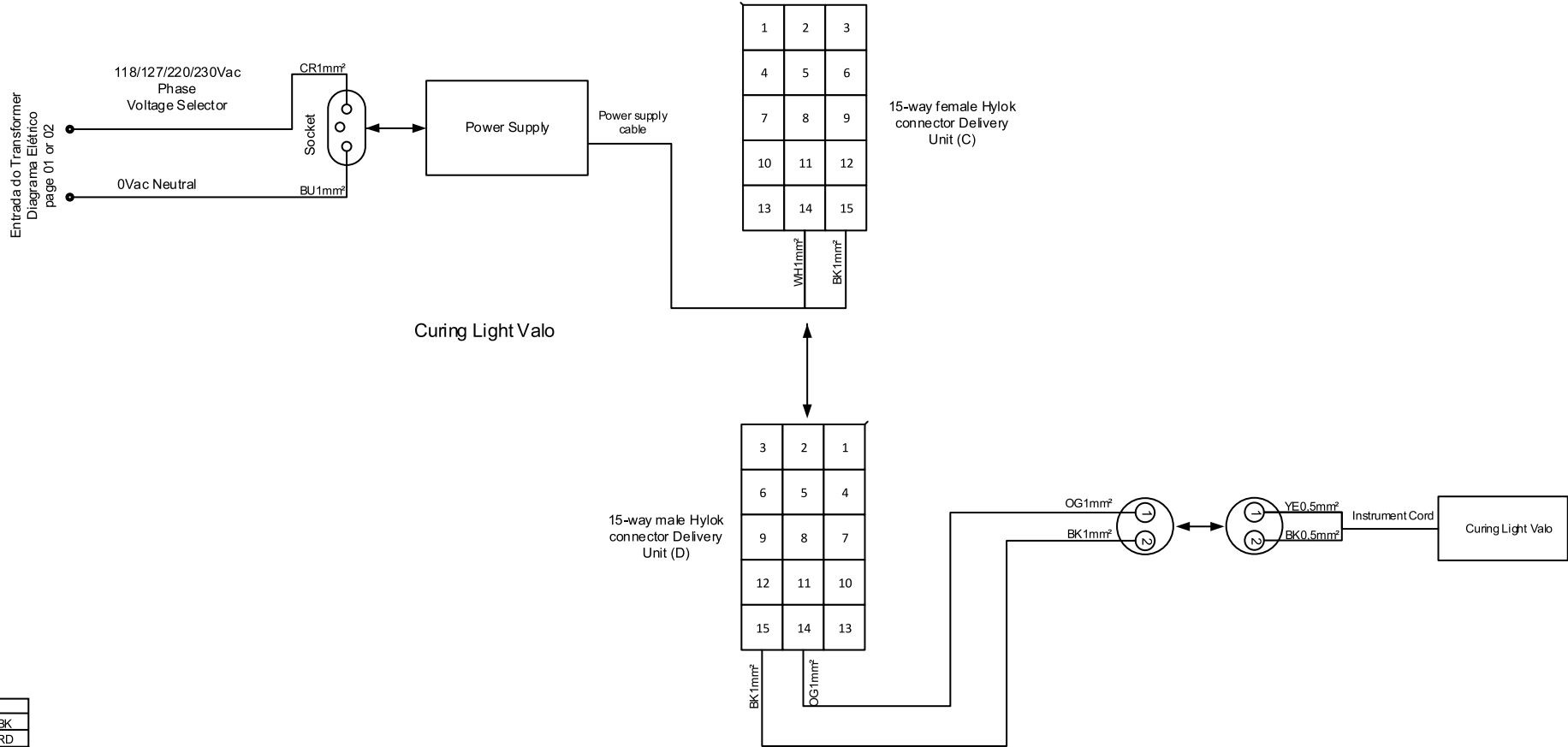

Color Legend	
Black	BK
Red	RD
Blue	BU
Green	GN
White	WH
Brown	BN
Violet	VT
Crystal	CR
Orange	OG
Yellow	YE
Pink	PK
Grey	GY
Green/Yellow	GN/YE
Blue/White	BU/WH
Red/White	RD/WH

Curing Light Valo Connection
-Optional items according to the equipment configuration grid

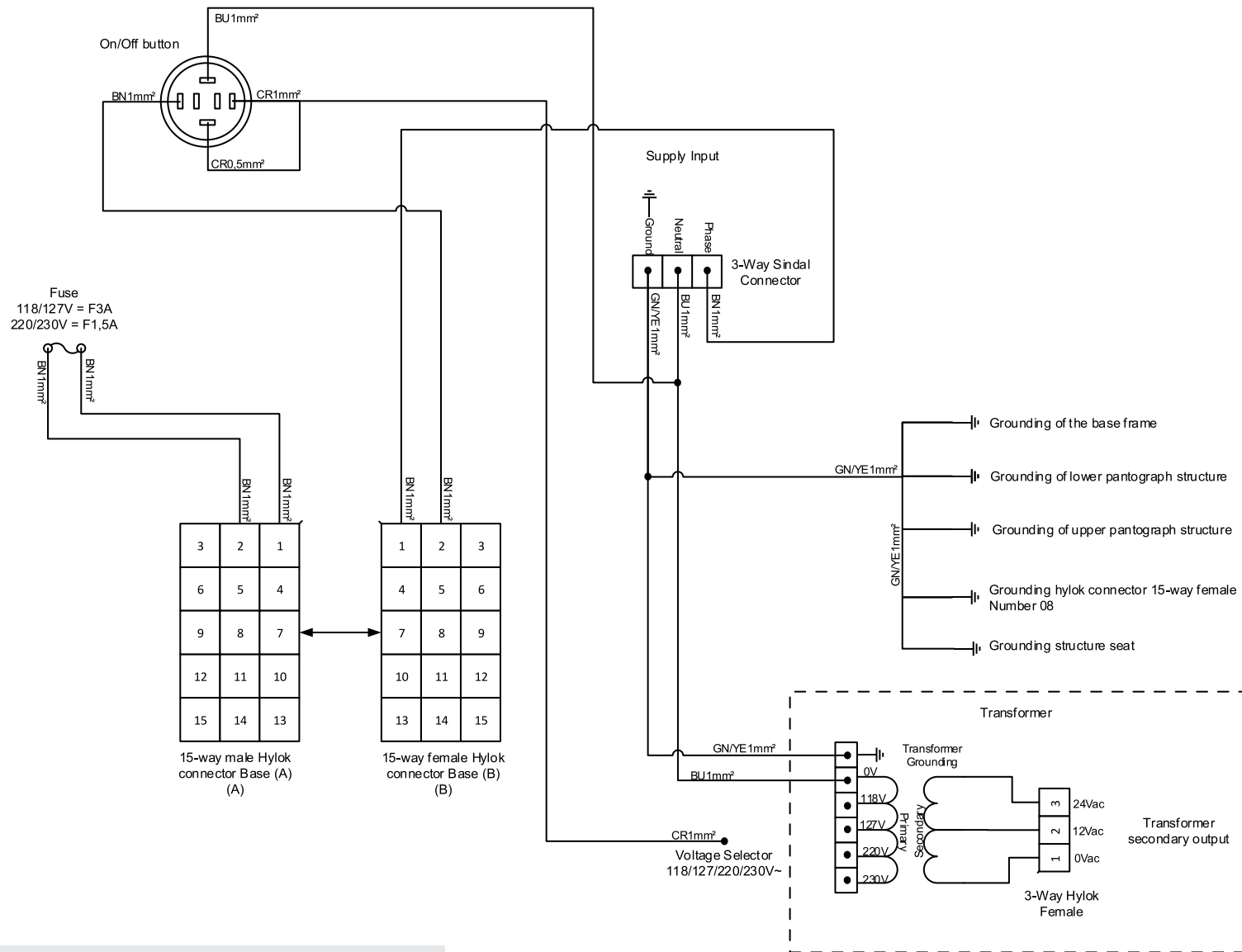

Color Legend	
Black	BK
Red	RD
Blue	BU
Green	GN
White	WH
Brown	BN
Violet	VT
Crystal	CR
Orange	OG
Yellow	YE
Pink	PK
Grey	GY
Green/Yellow	GN/YE
Blue/White	BU/WH
Red/White	RD/WH

Chair
 -Electrical part + Grounding
 -Optional items according to the equipment configuration grid

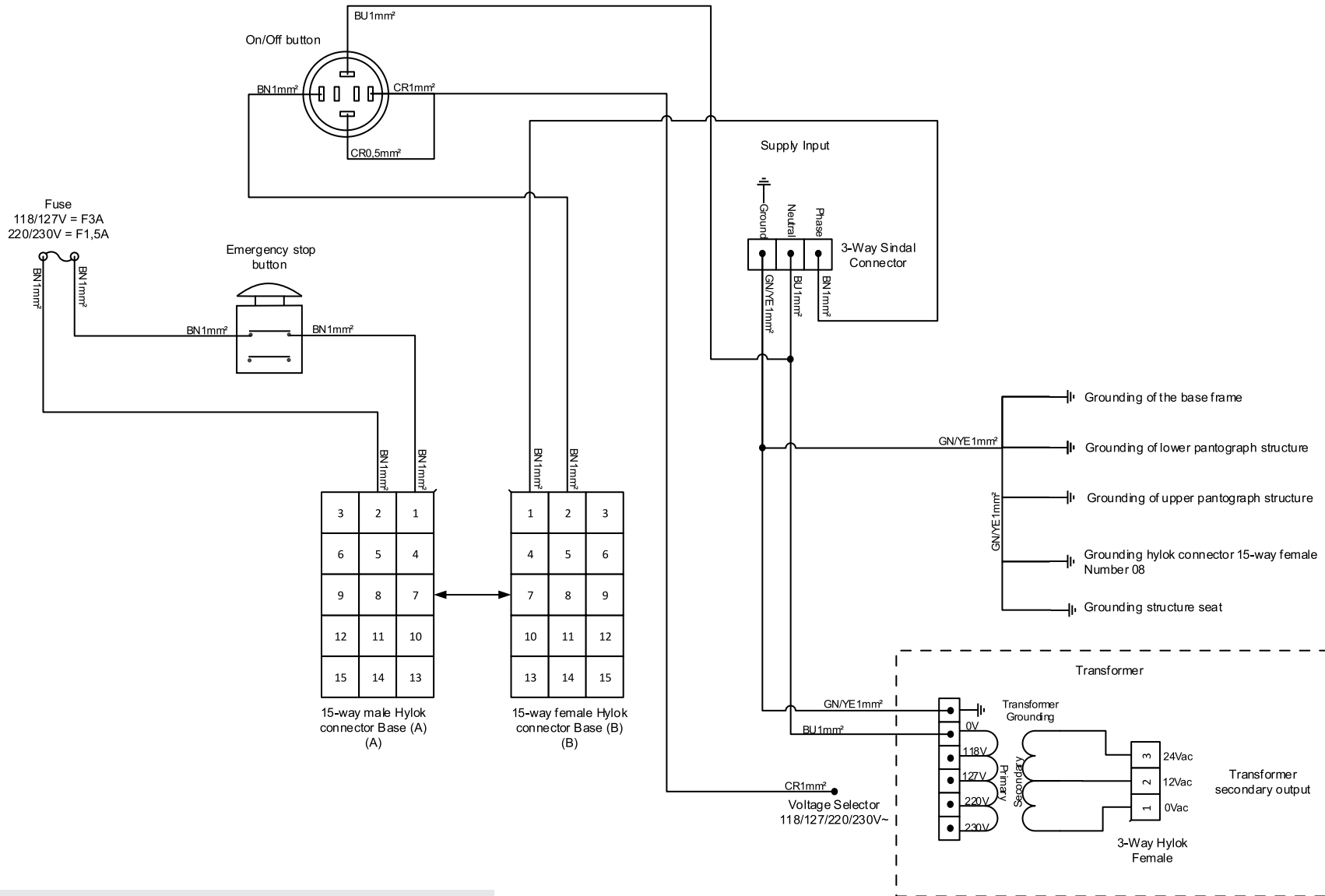

Color Legend	
Black	BK
Red	RD
Blue	BU
Green	GN
White	WH
Brown	BN
Violet	VT
Crystal	CR
Orange	OG
Yellow	YE
Pink	PK
Grey	GY
Green/Yellow	GN/YE
Blue/White	BU/WH
Red/White	RD/WH

Chair
 -Electrical part + Grounding + Emergency stop button
 -Optional items according to the equipment configuration grid

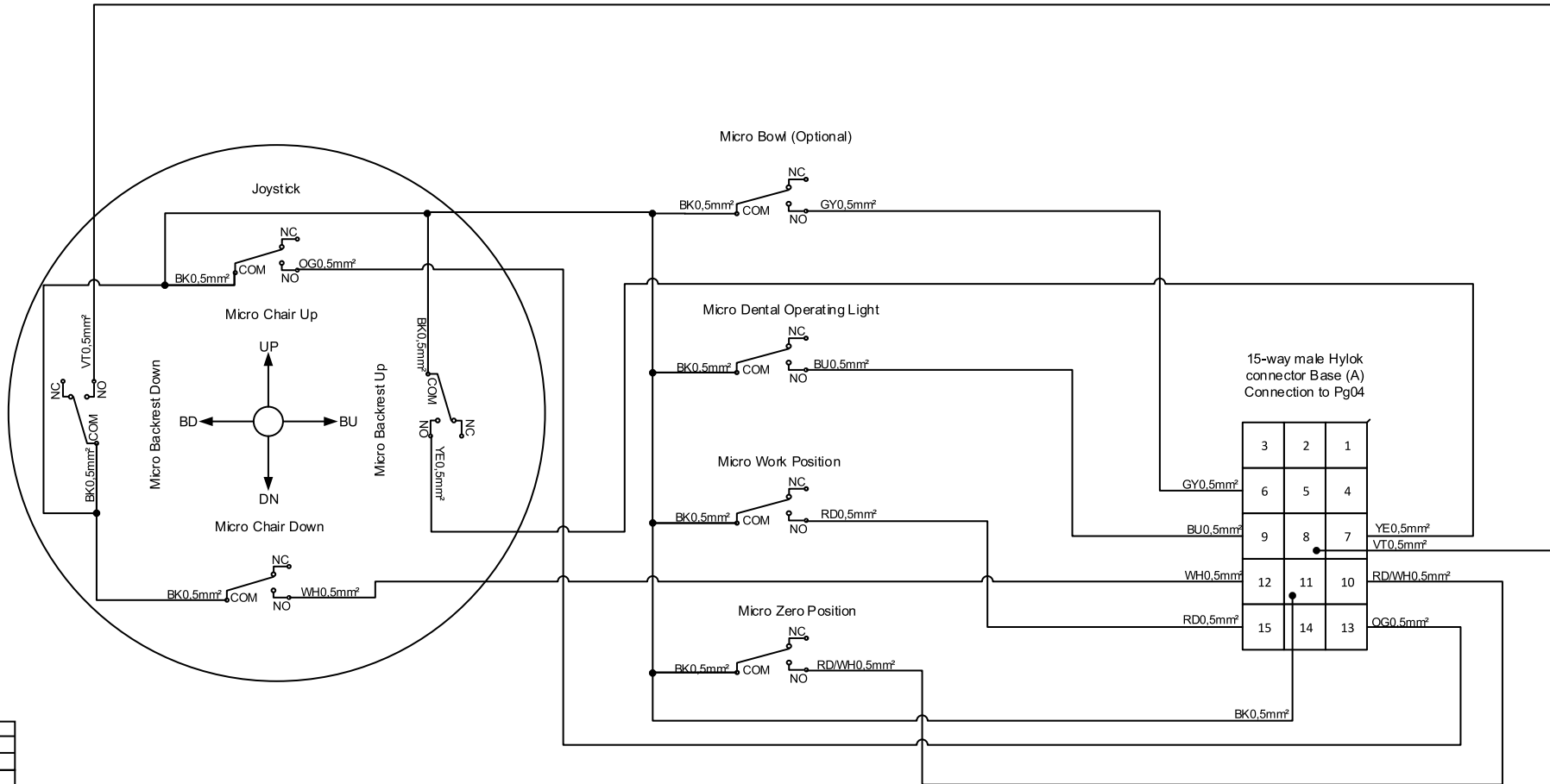

Color Legend	
Black	BK
Red	RD
Blue	BU
Green	GN
White	WH
Brown	BN
Violet	VT
Crystal	CR
Orange	OG
Yellow	YE
Pink	PK
Grey	GY
Green/Yellow	GN/YE
Blue/White	BU/WH
Red/White	RD/WH

Chair base control connection
 -Optional items according to the equipment configuration grid

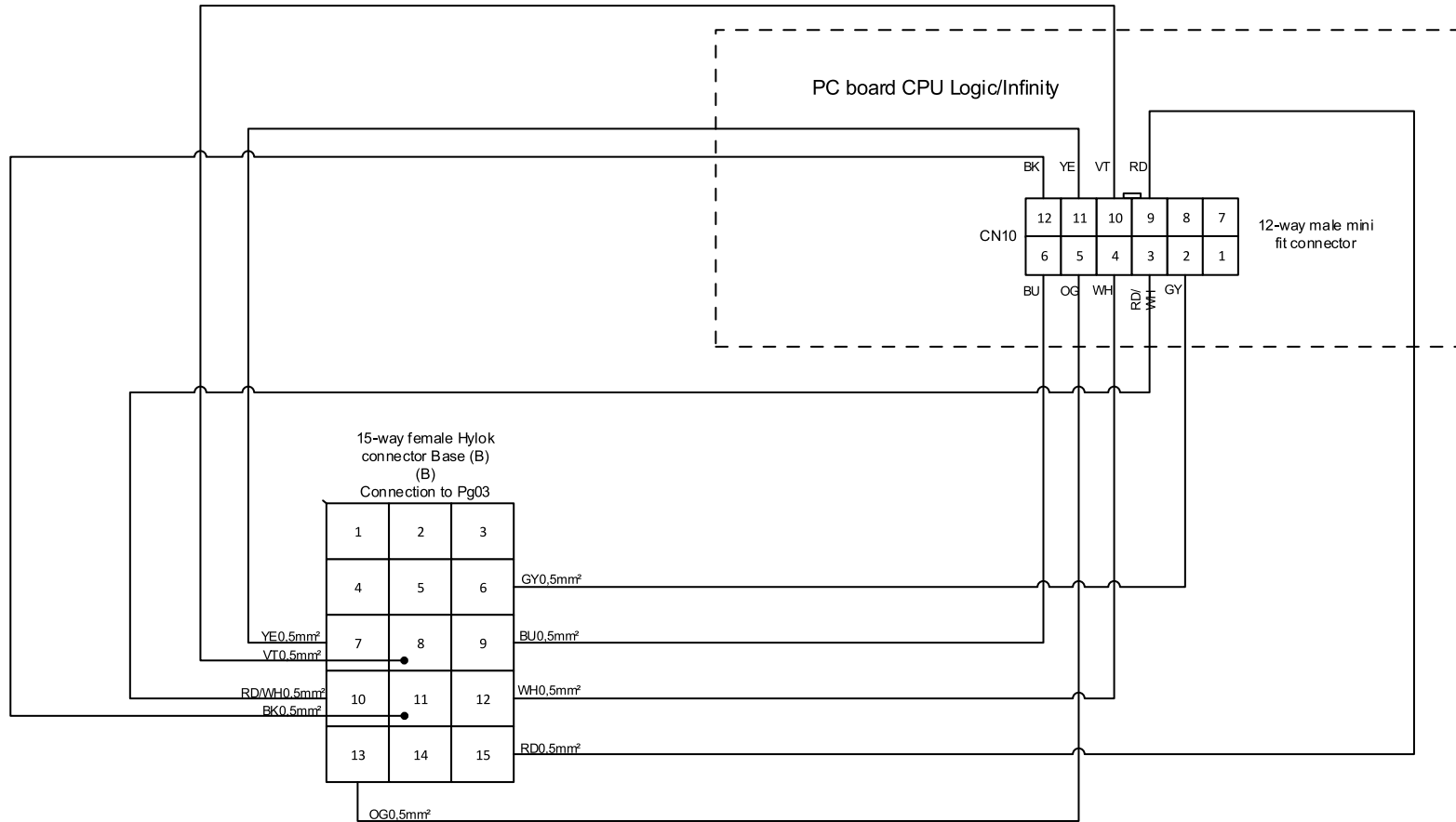

Color Legend	
Black	BK
Red	RD
Blue	BU
Green	GN
White	WH
Brown	BN
Violet	VT
Crystal	CR
Orange	OG
Yellow	YE
Pink	PK
Grey	GY
Green/Yellow	GN/YE
Blue/White	BU/WH
Red/White	RD/WH

Chair base control connection-Optional items according to the equipment configuration grid

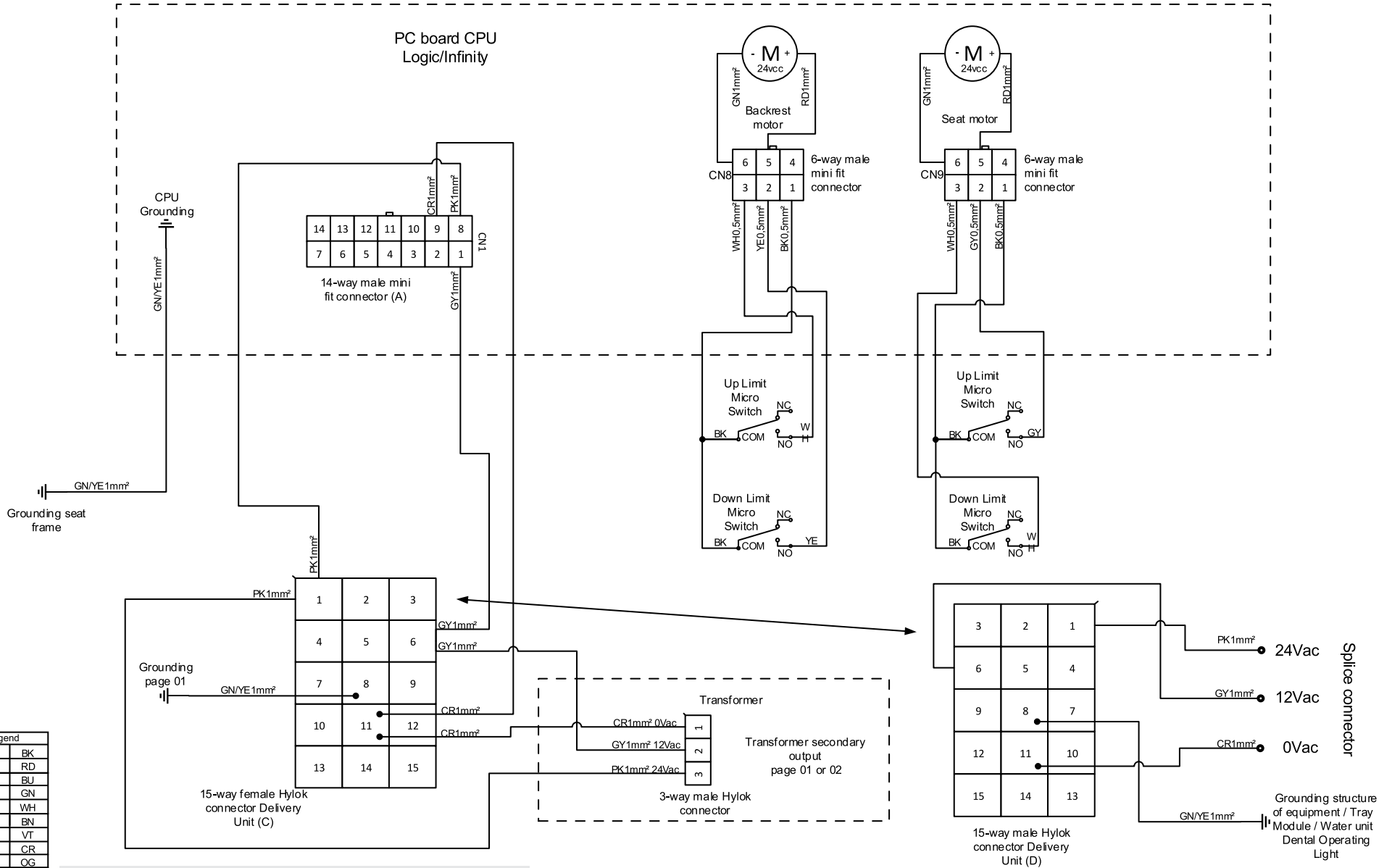

Color Legend	
Black	BK
Red	RD
Blue	BU
Green	GN
White	WH
Brown	BN
Violet	VT
Crystal	CR
Orange	OG
Yellow	YE
Pink	PK
Grey	GY
Green/Yellow	GN/YE
Blue/White	BU/WH
Red/White	RD/WH

Connection CPU PC board and Motors
-Optional items according to the equipment configuration grid

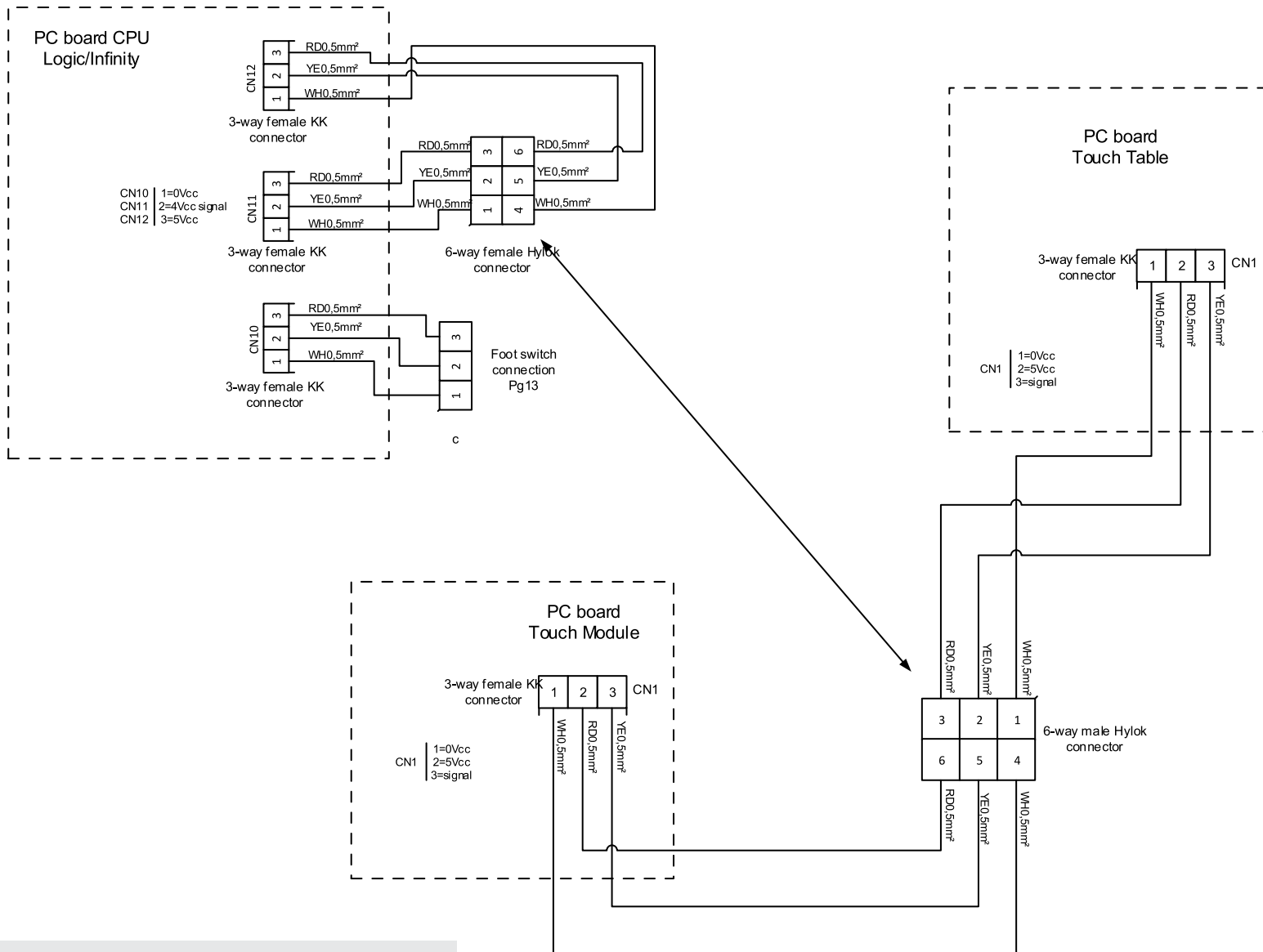

Color Legend	
Black	BK
Red	RD
Blue	BU
Green	GN
White	WH
Brown	BN
Violet	VT
Crystal	CR
Orange	OG
Yellow	YE
Pink	PK
Grey	GY
Green/Yellow	GN/YE
Blue/White	BU/WH
Red/White	RD/WH

Touch connection
-Optional items according to the equipment configuration grid

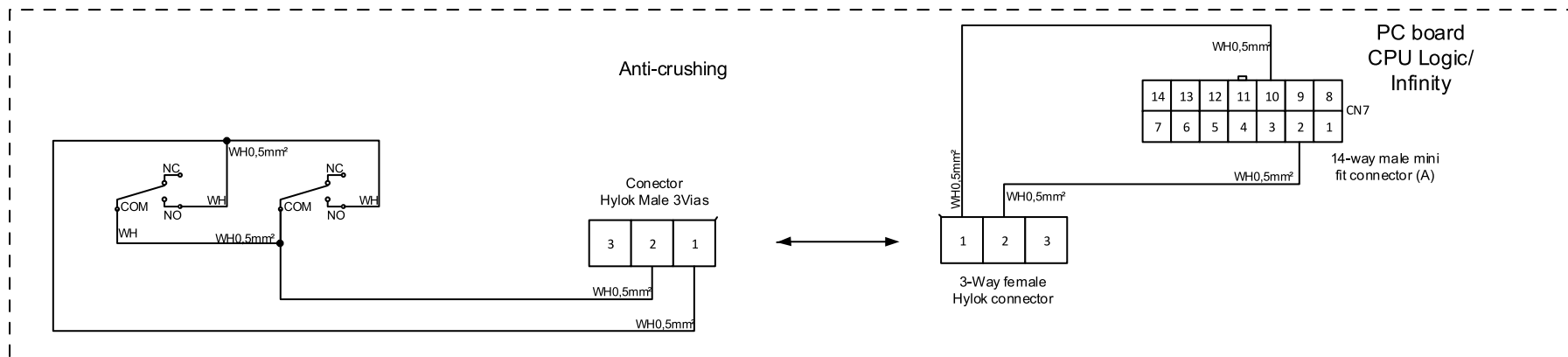
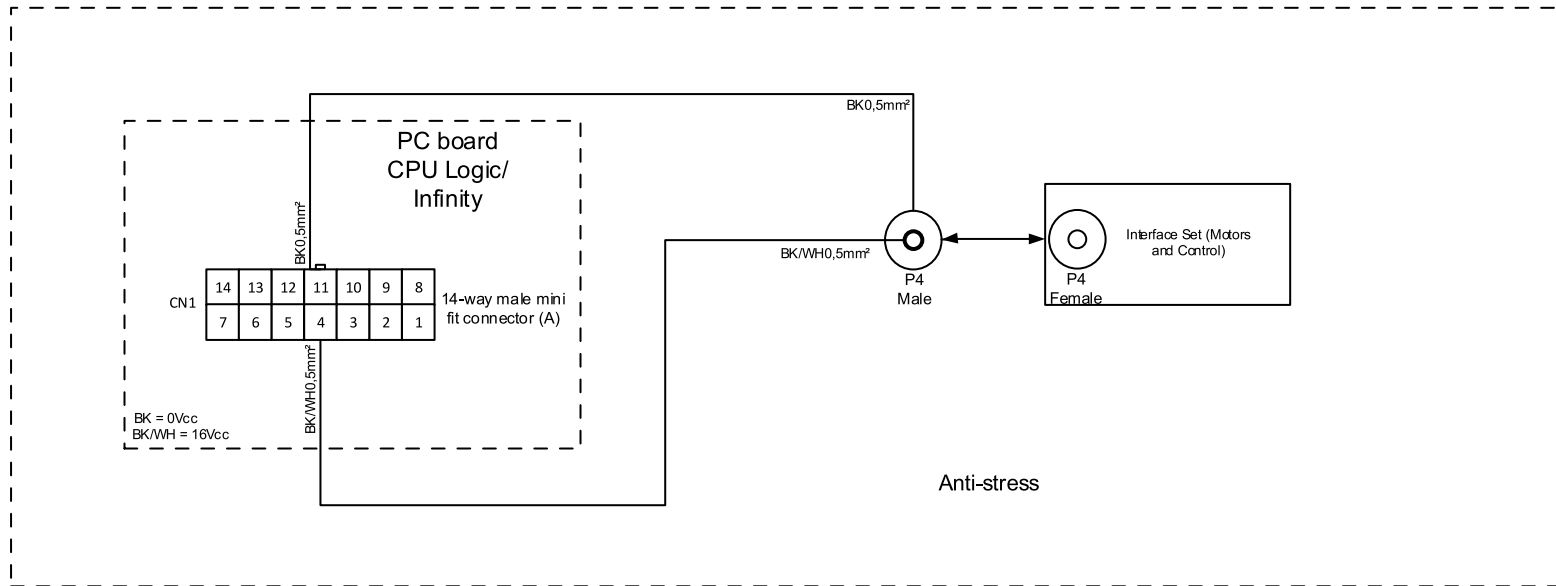

Color Legend	
Black	BK
Red	RD
Blue	BU
Green	GN
White	WH
Brown	BN
Violet	VT
Crystal	CR
Orange	OG
Yellow	YE
Pink	PK
Grey	GY
Green/Yellow	GN/YE
Blue/White	BU/WH
Red/White	RD/WH

Anti-stress and Anti-crushing connection
-Optional items according to the equipment configuration grid

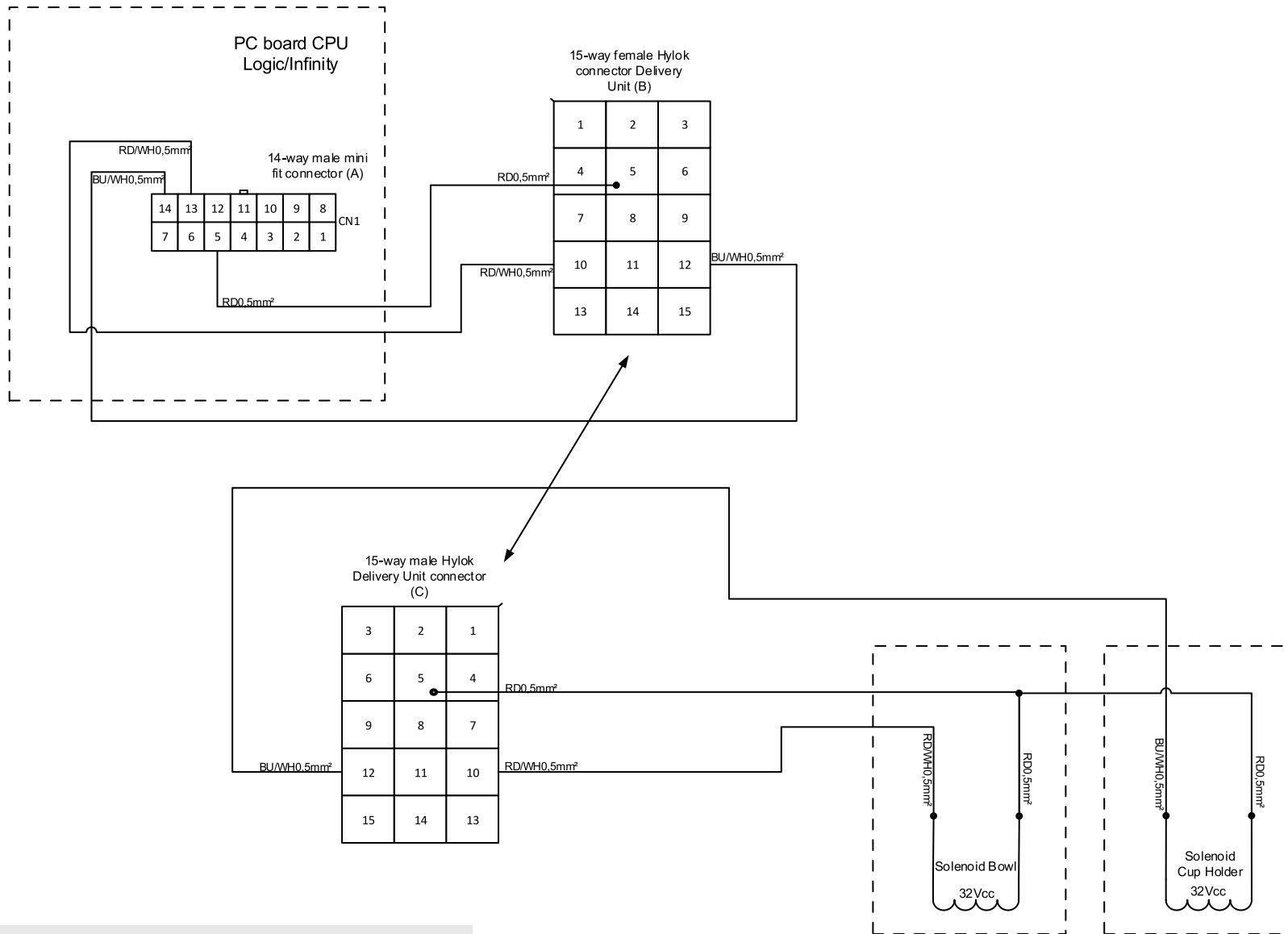

Color Legend	
Black	BK
Red	RD
Blue	BU
Green	GN
White	WH
Brown	BN
Violet	VT
Crystal	CR
Orange	OG
Yellow	YE
Pink	PK
Grey	GY
Green/Yellow	GN/YE
Blue/White	BU/WH
Red/White	RD/WH

Solenoid Bowl and Cup Holder connection on the equipment
 -Optional items according to the equipment configuration grid

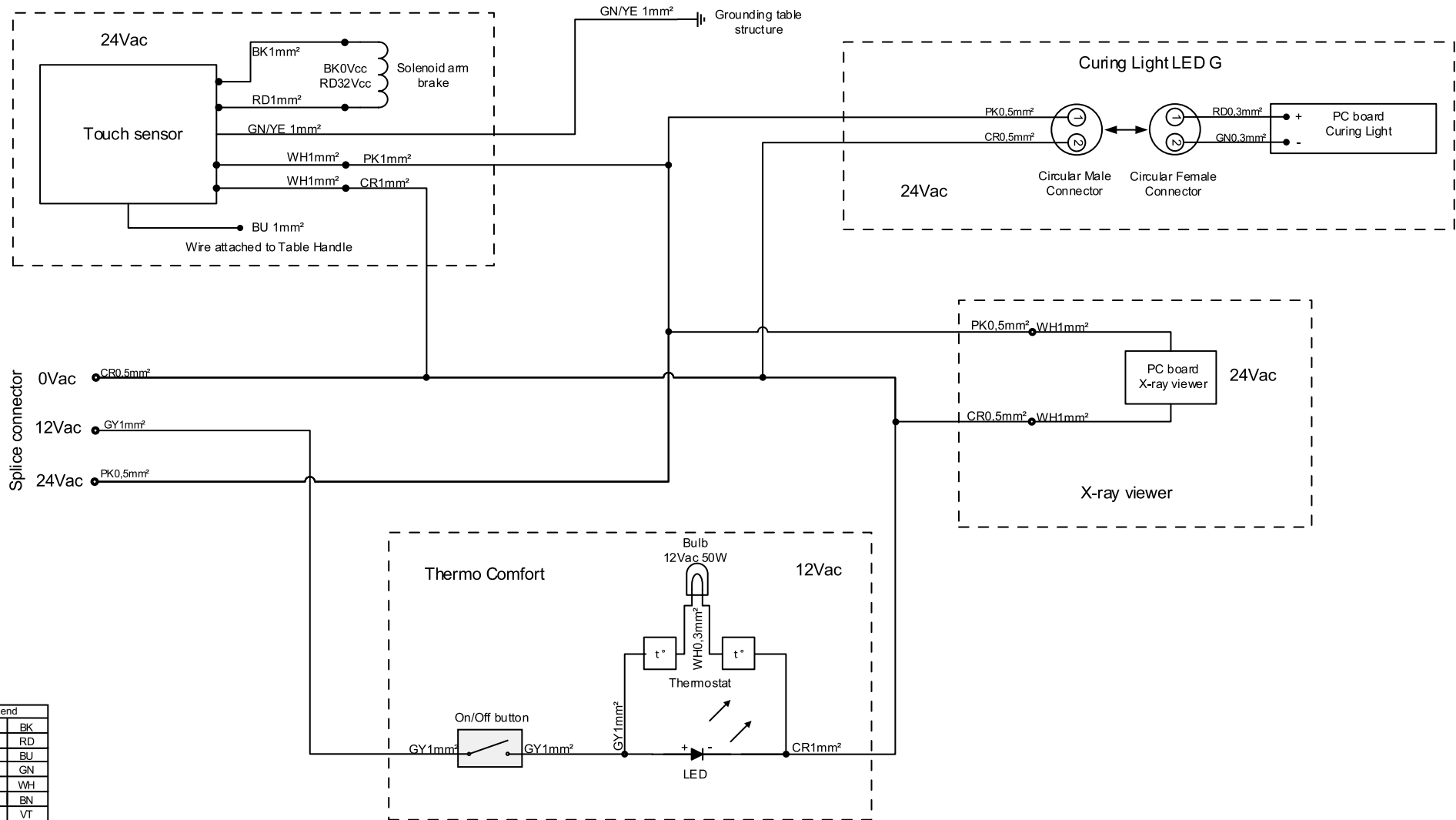

Color Legend	
Black	BK
Red	RD
Blue	BU
Green	GN
White	WH
Brown	BN
Violet	VT
Crystal	CR
Orange	OG
Yellow	YE
Pink	PK
Grey	GY
Green/Yellow	GN/YE
Blue/White	BU/WH
Red/White	RD/WH

Touch sensor connection, Photopolymerizer, X-Ray Viewer and Thermo Comfort
 -Optional items according to the equipment configuration grid

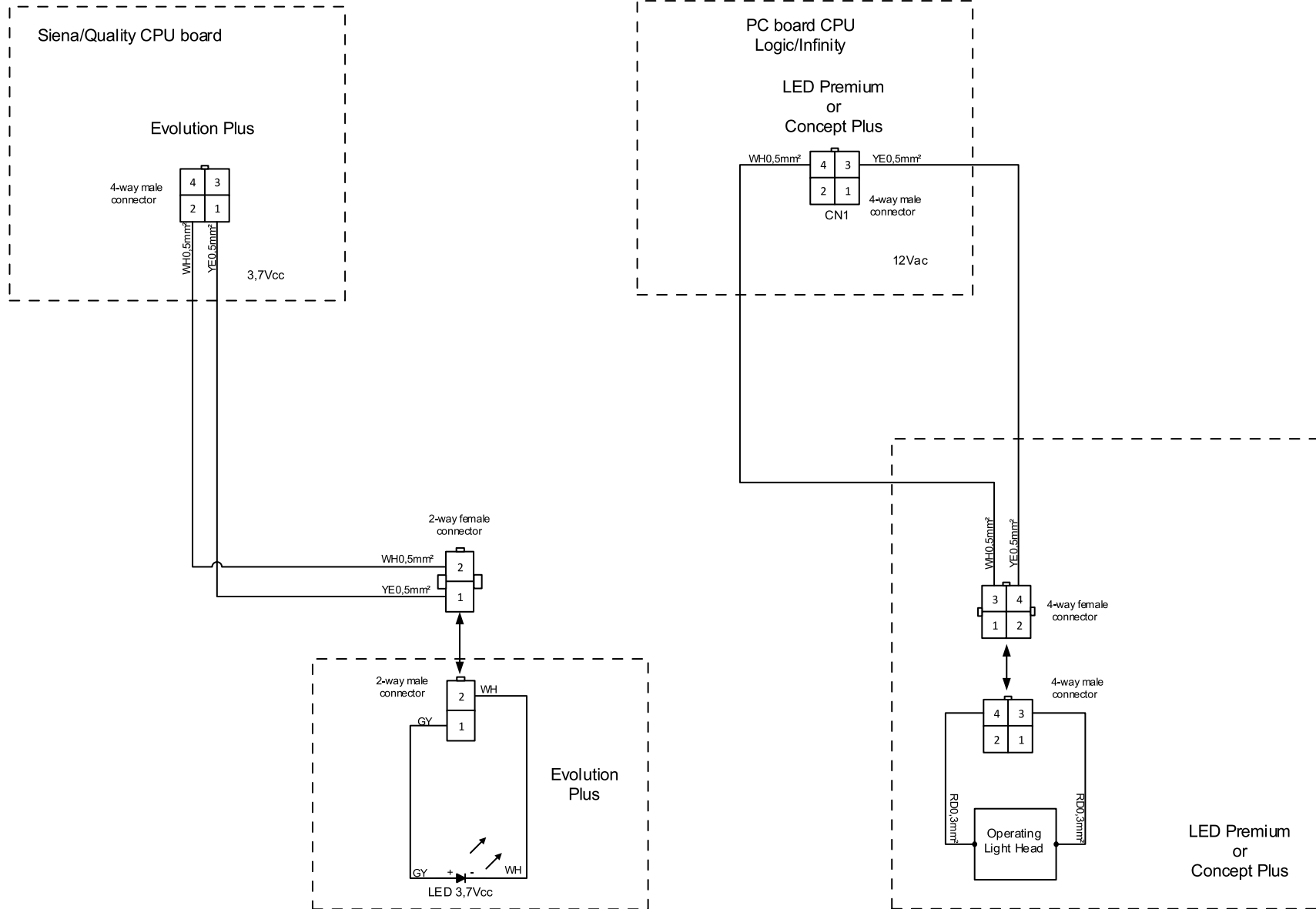

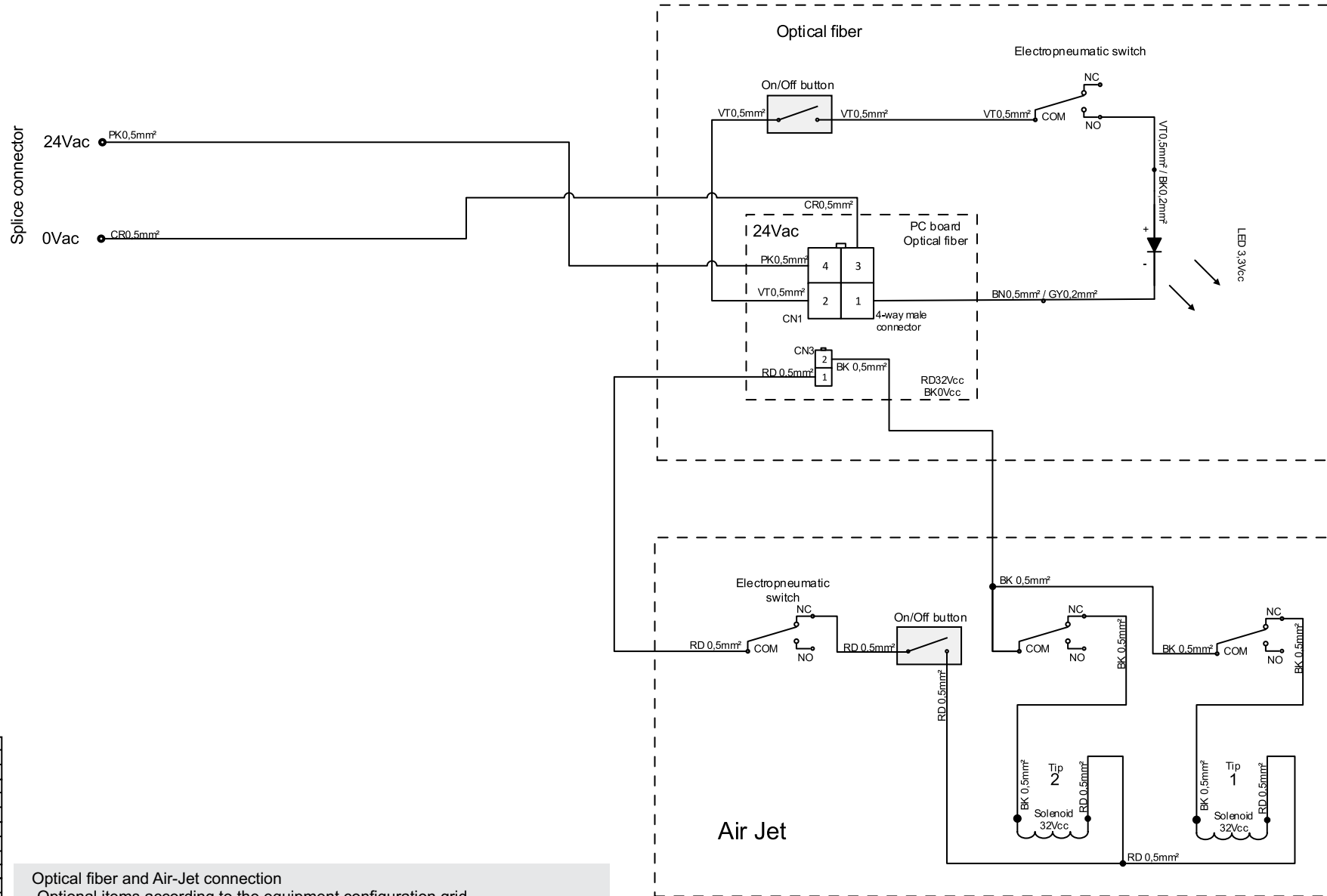

Color Legend	
Black	BK
Red	RD
Blue	BU
Green	GN
White	WH
Brown	BN
Violet	VT
Crystal	CR
Orange	OG
Yellow	YE
Pink	PK
Grey	GY
Green/Yellow	GN/YE
Blue/White	BU/WH
Red/White	RD/WH

Optical fiber and Air-Jet connection
 -Optional items according to the equipment configuration grid
 -Only with Air-Jet, use a PC Optical fiber CN3 output board
 -If Optical fiber and Air-Jet are requested, do not use the On/Off button of Optical fiber

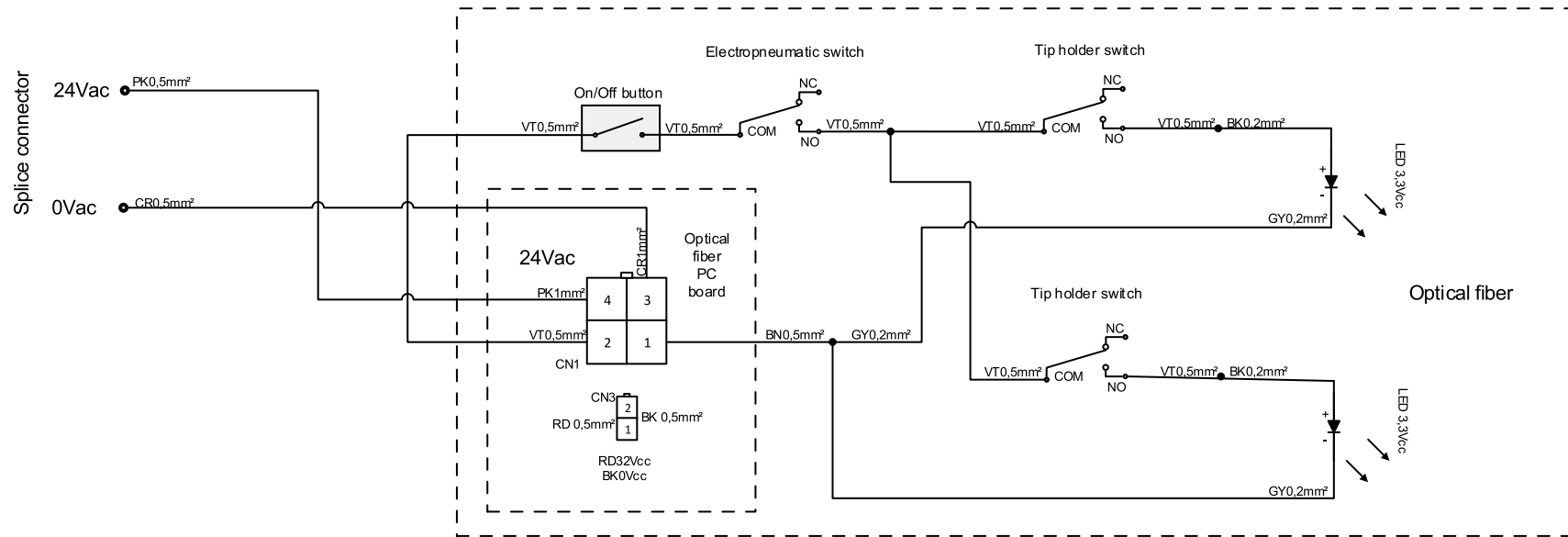

Color Legend	
Black	BK
Red	RD
Blue	BU
Green	GN
White	WH
Brown	BN
Violet	VT
Crystal	CR
Orange	OG
Yellow	YE
Pink	PK
Grey	GY
Green/Yellow	GN/YE
Blue/White	BU/WH
Red/White	RD/WH

Connection with Two Optical Fiber
 -Optional items according to the equipment configuration grid
 -With Air-Jet only, use a CN3 PC Fiber Optic output board
 -If Optical fiber and Air-Jet requested, do not use the Optical fiber On/Off button

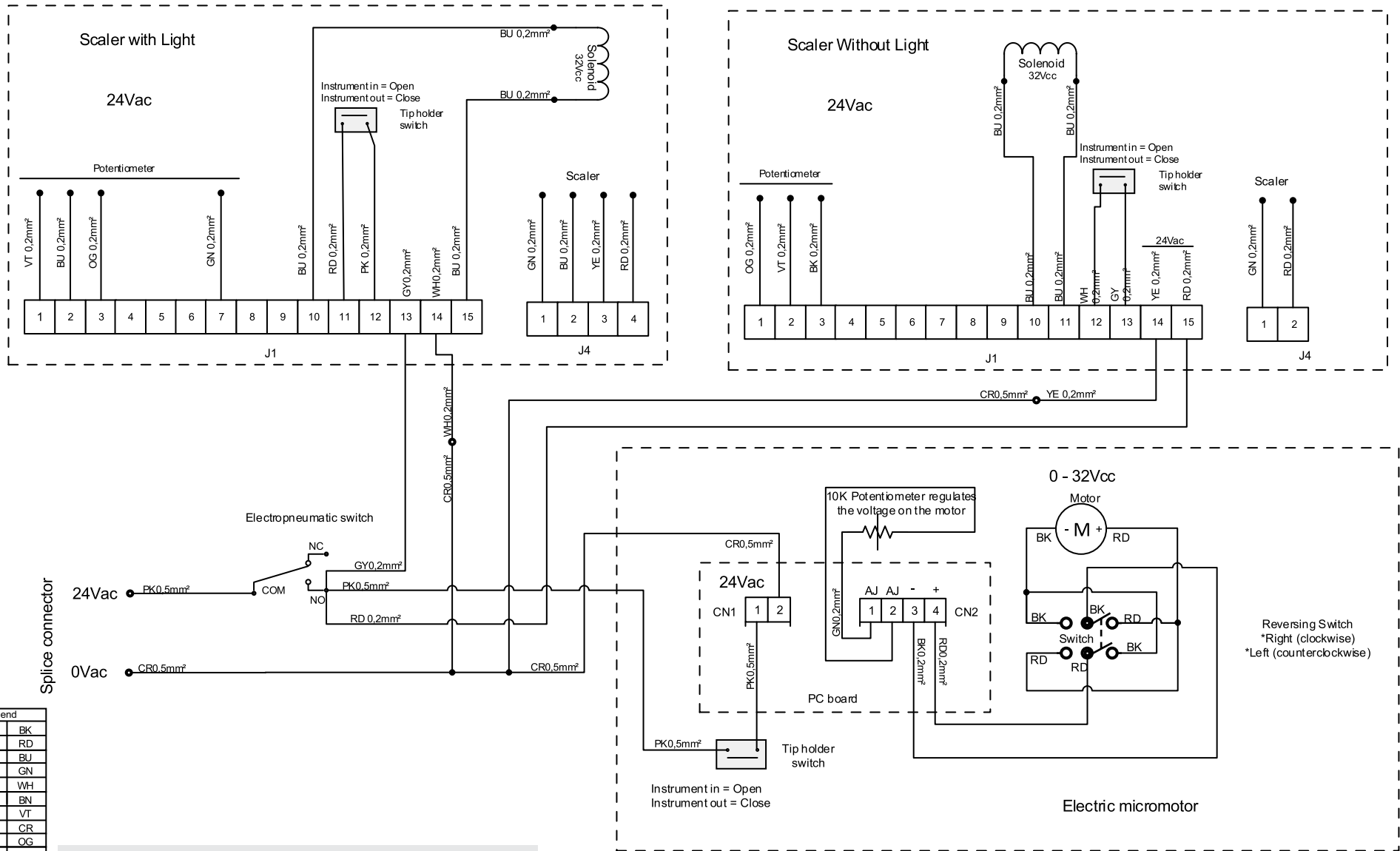

Color Legend	
Black	BK
Red	RD
Blue	BU
Green	GN
White	WH
Brown	BN
Violet	VT
Crystal	CR
Orange	OG
Yellow	YE
Pink	PK
Grey	GY
Green/Yellow	GN/YE
Blue/White	BU/WH
Red/White	RD/WH

Scaler and Electrical Micromotor Connection
-Optional items according to the equipment configuration grid

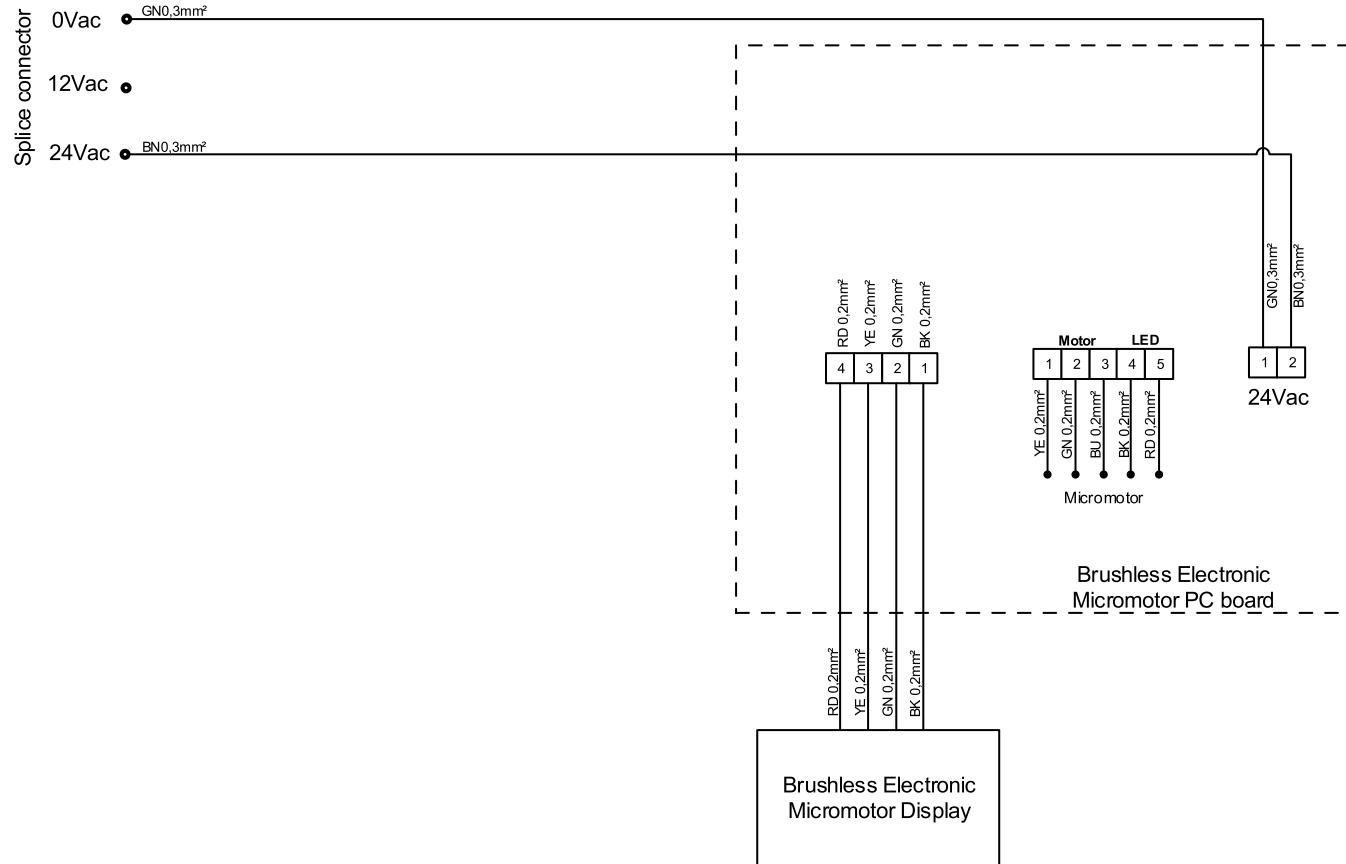

Color Legend	
Black	BK
Red	RD
Blue	BU
Green	GN
White	WH
Brown	BN
Violet	VT
Crystal	CR
Orange	OG
Yellow	YE
Pink	PK
Grey	GY
Green/Yellow	GN/YE
Blue/White	BU/WH
Red/White	RD/WH

Brushless electronic micromotor connection
 -Optional items according to the equipment configuration grid

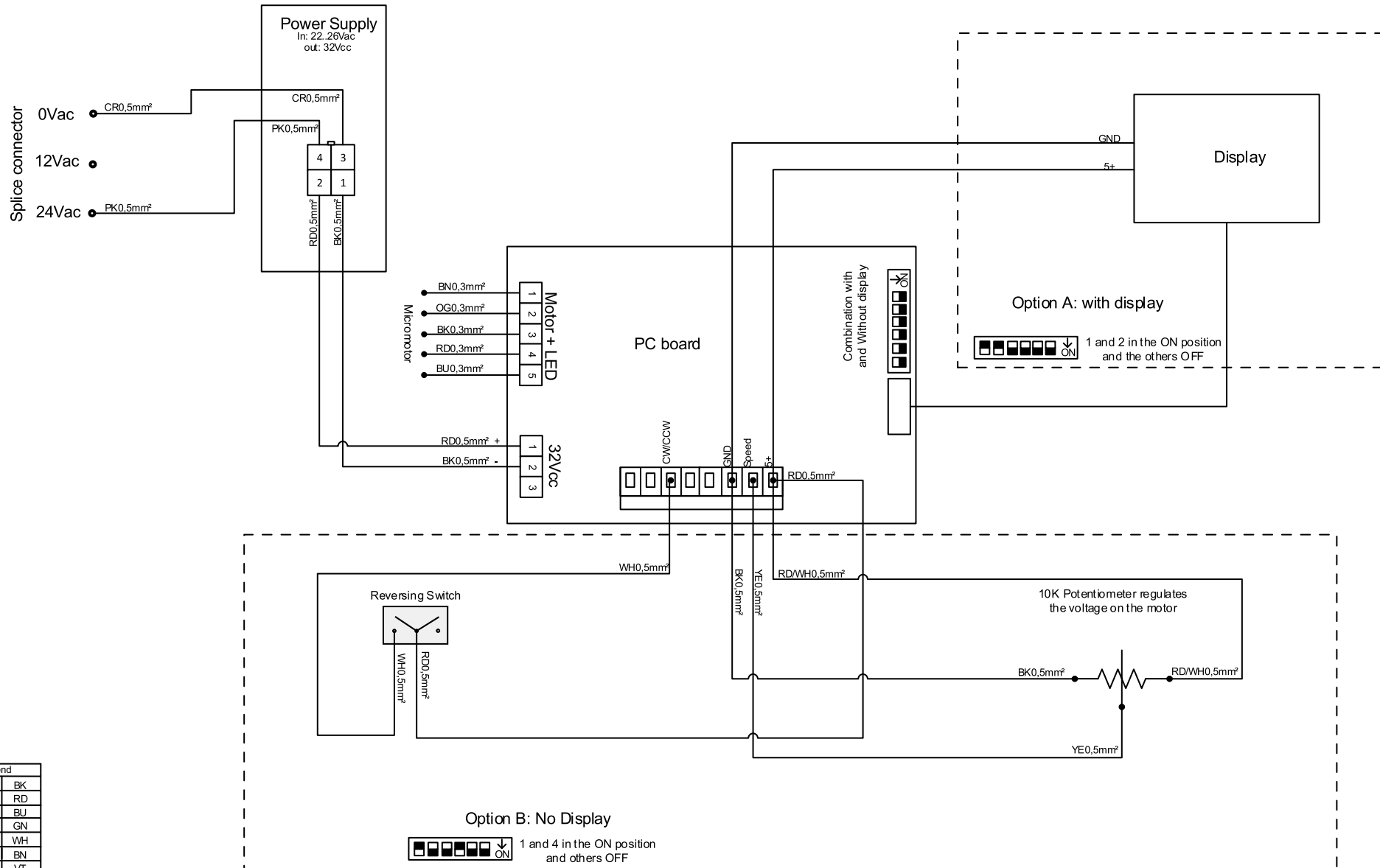

Color Legend	
Black	BK
Red	RD
Blue	BU
Green	GN
White	WH
Brown	BN
Violet	VT
Crystal	CR
Orange	OG
Yellow	YE
Pink	PK
Grey	GY
Green/Yellow	GN/YE
Blue/White	BU/WH
Red/White	RD/WH

Micromotor Bien Air connection
 -Optional items according to the equipment configuration grid

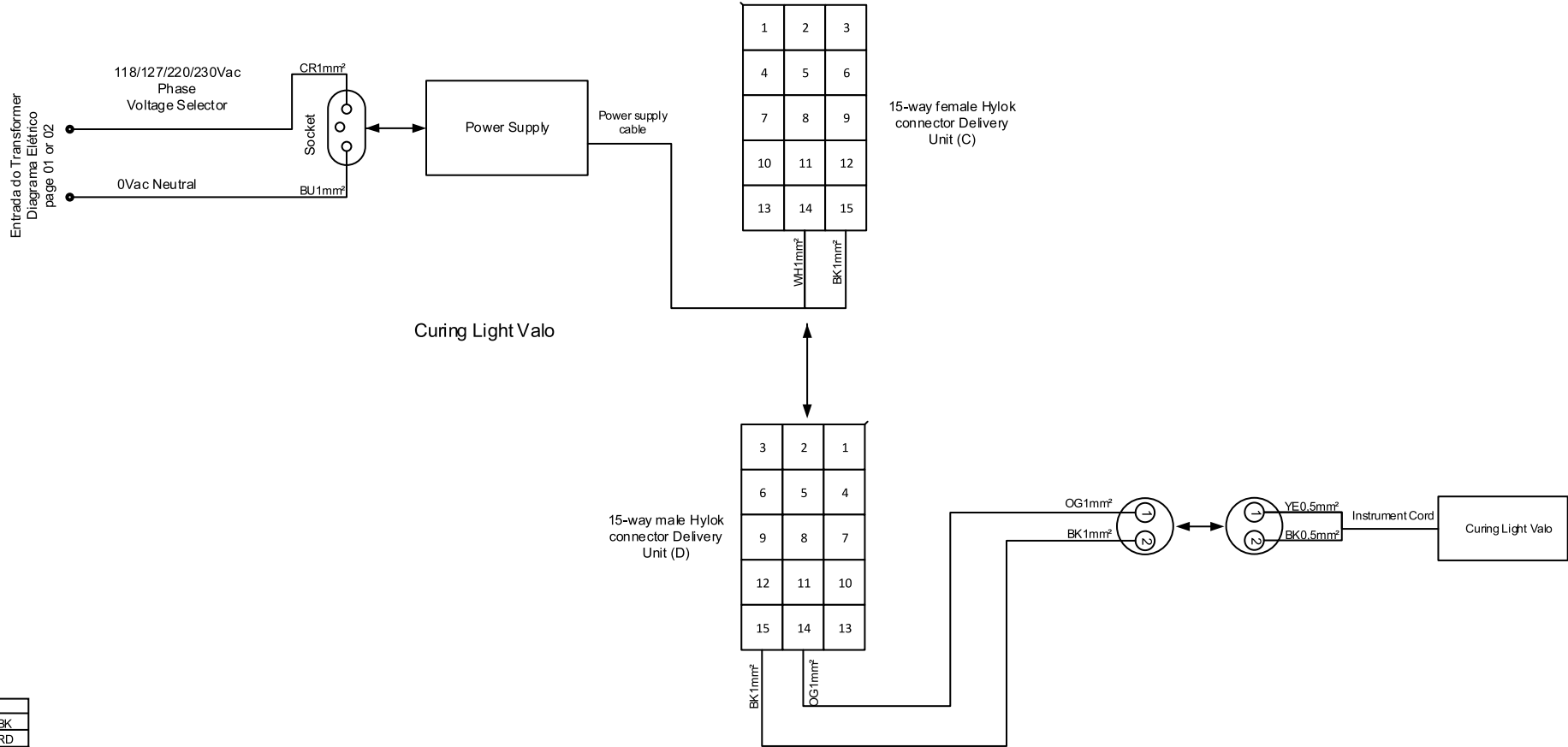

Color Legend	
Black	BK
Red	RD
Blue	BU
Green	GN
White	WH
Brown	BN
Violet	VT
Crystal	CR
Orange	OG
Yellow	YE
Pink	PK
Grey	GY
Green/Yellow	GN/YE
Blue/White	BU/WH
Red/White	RD/WH

Curing Light Valo Connection
-Optional items according to the equipment configuration grid

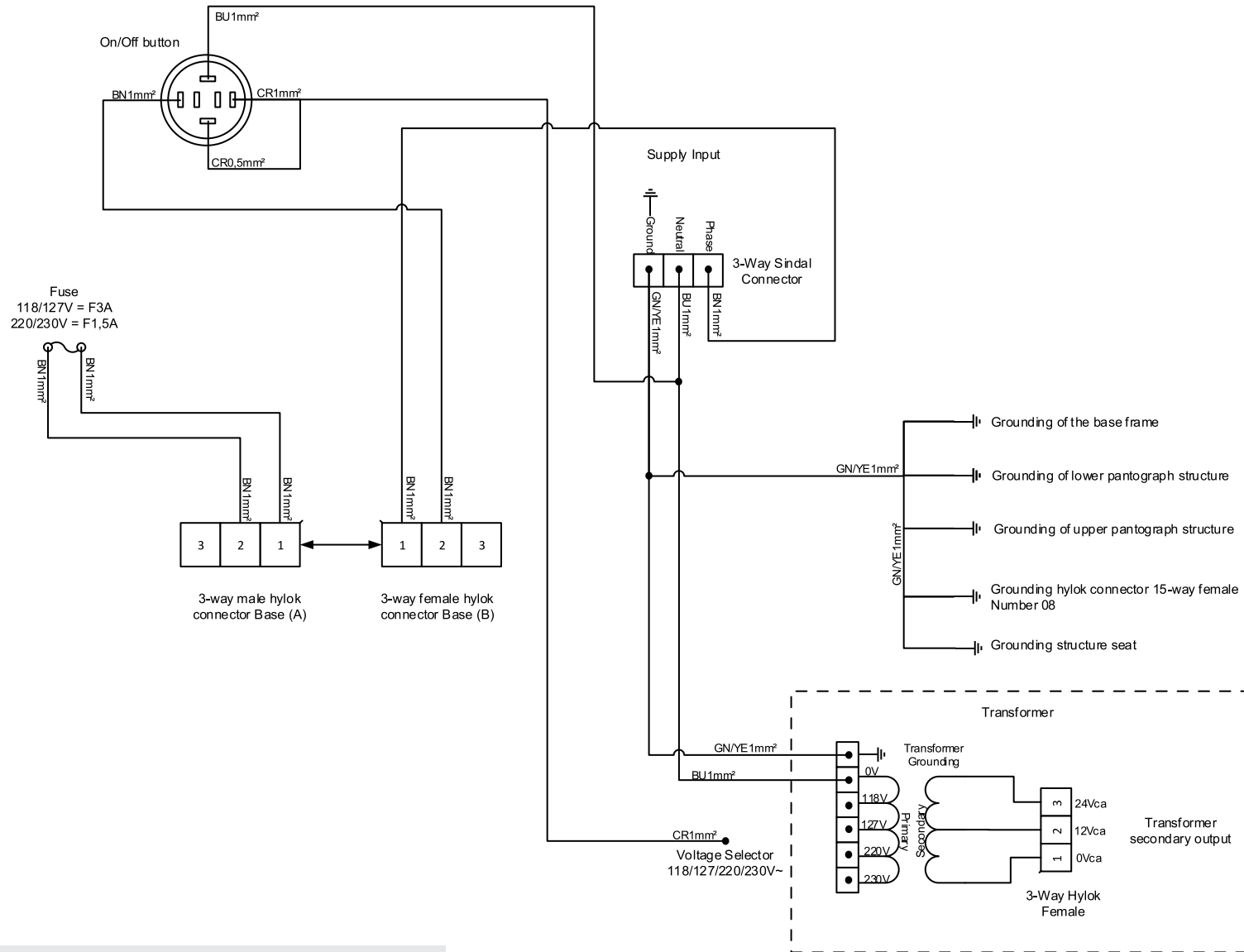

Color Legend		
Black	BK	
Red	RD	
Blue	BU	
Green	GN	
White	WH	
Brown	BN	
Violet	VT	
Crystal	CR	
Orange	OG	
Yellow	YE	
Pink	PK	
Grey	GY	
Green/Yellow	GN/YE	
Blue/White	BU/WH	
Red/White	RD/WH	

Chair
 -Electrical part + Grounding
 -Optional items according to the equipment configuration grid

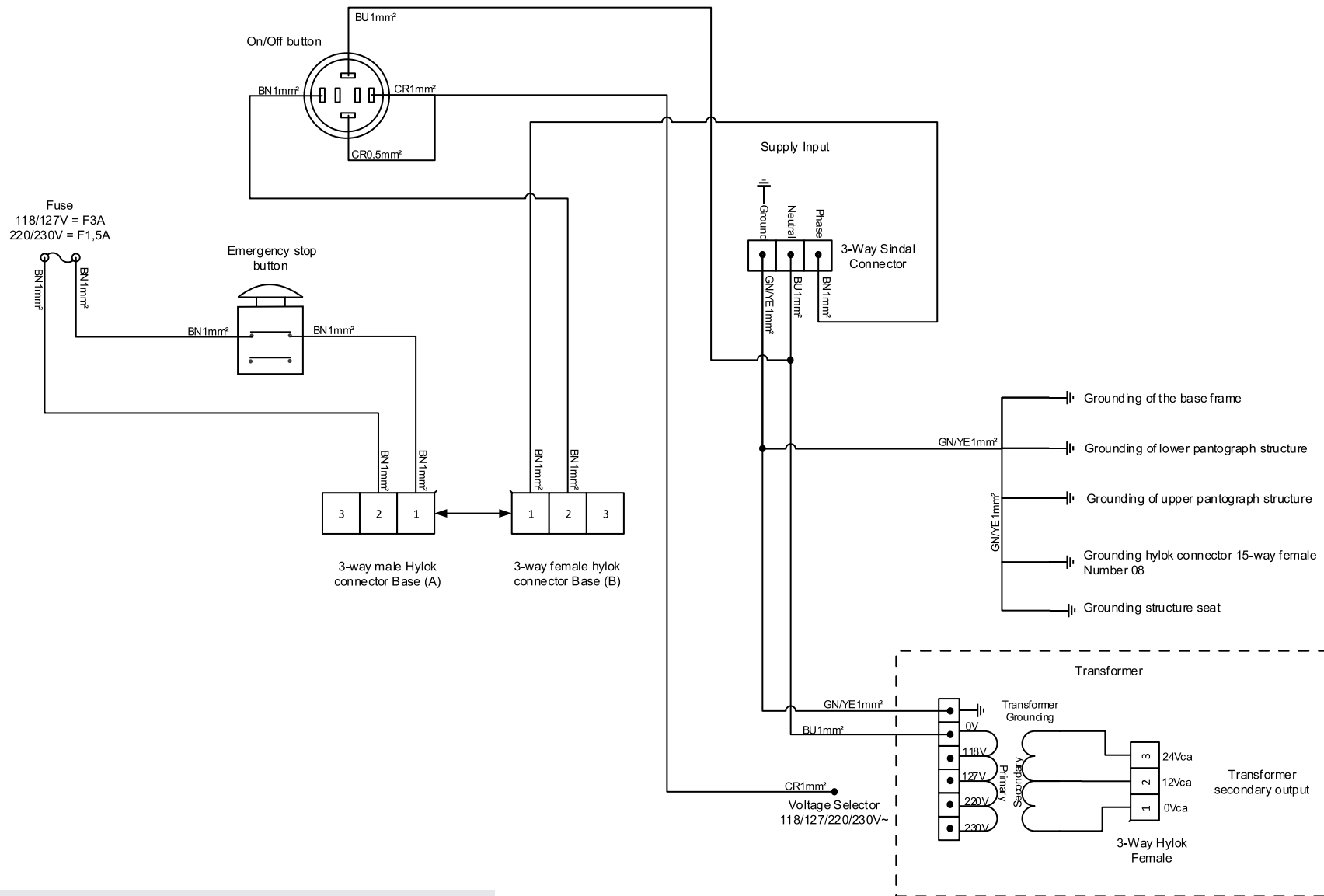

Color Legend	
Black	BK
Red	RD
Blue	BU
Green	GN
White	WH
Brown	BN
Violet	VT
Crystal	CR
Orange	OG
Yellow	YE
Pink	PK
Grey	GY
Green/Yellow	GN/YE
Blue/White	BU/WH
Red/White	RD/WH

Chair
 -Electric part + Grounding + Emergency stop button
 -Optional items according to the equipment configuration grid

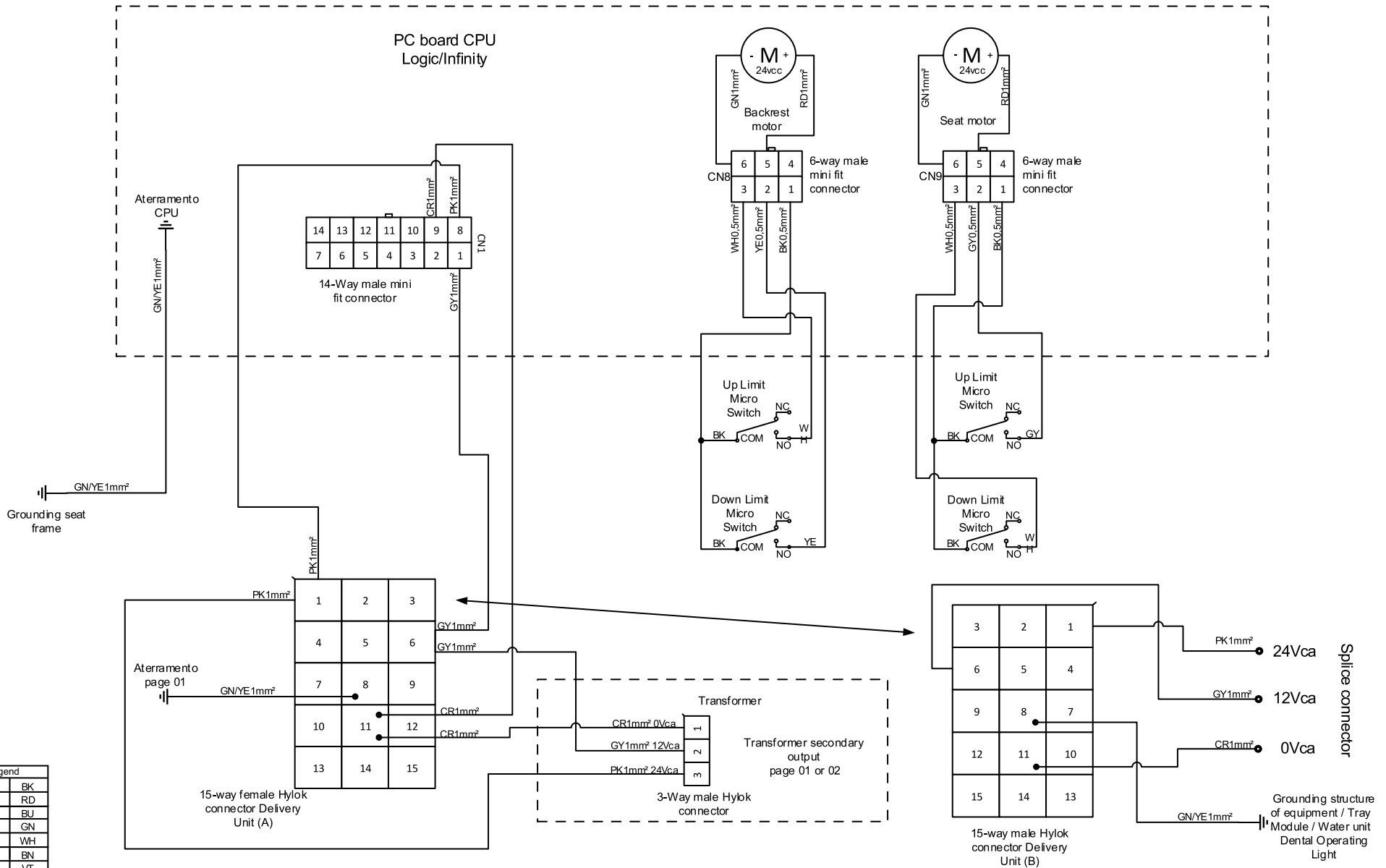

Color Legend	
Black	BK
Red	RD
Blue	BU
Green	GN
White	WH
Brown	BN
Violet	VT
Crystal	CR
Orange	OG
Yellow	YE
Pink	PK
Grey	GY
Green/Yellow	GN/YE
Blue/White	BU/WH
Red/White	RD/WH

CPU PC board and motors connection
-Optional items according to the equipment configuration grid

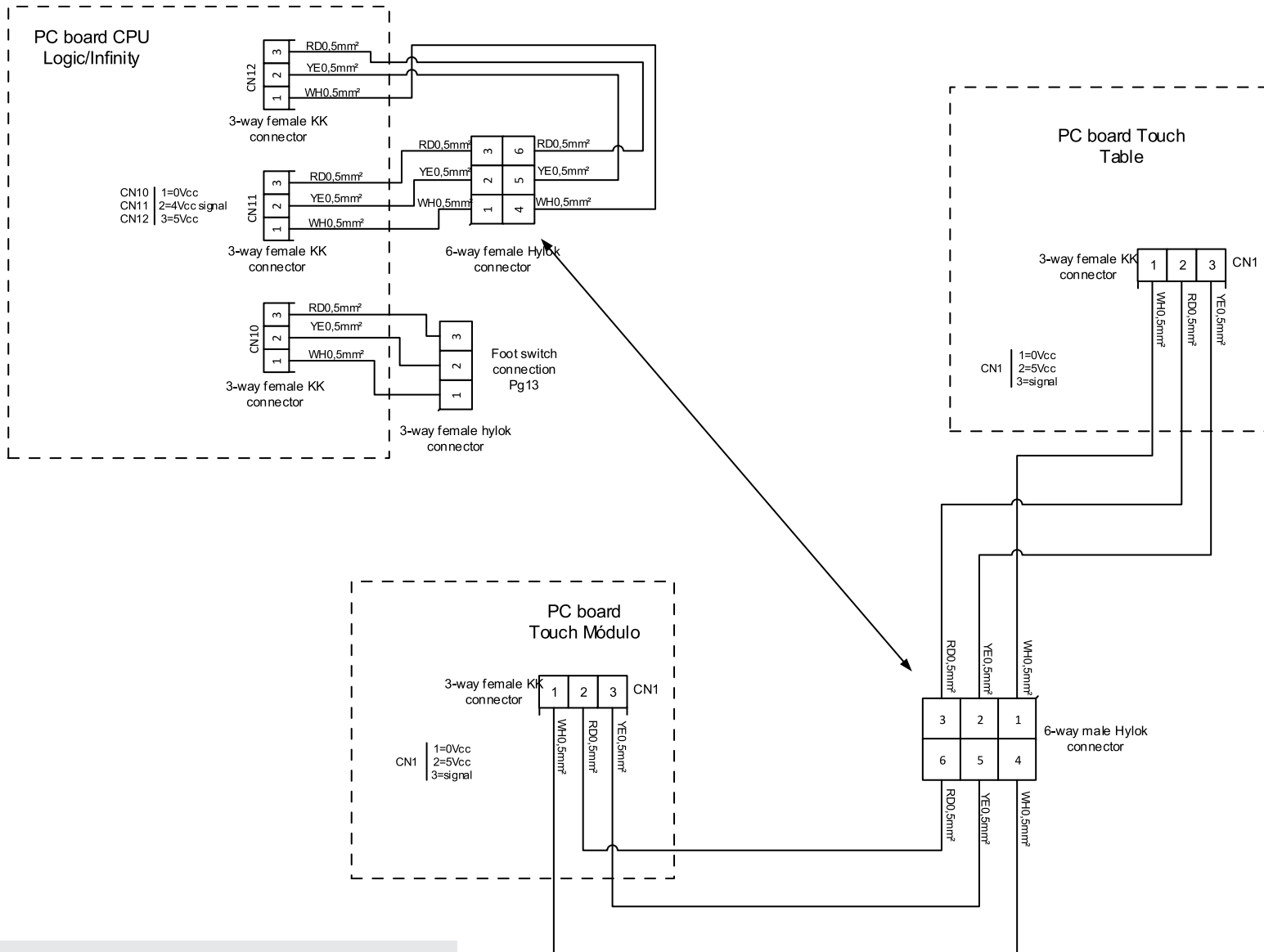

Color Legend	
Black	BK
Red	RD
Blue	BU
Green	GN
White	WH
Brown	BN
Violet	VT
Crystal	CR
Orange	OG
Yellow	YE
Pink	PK
Grey	GY
Green/Yellow	GN/YE
Blue/White	BU/WH
Red/White	RD/WH

Touch connection
 -Optional items according to the equipment configuration grid

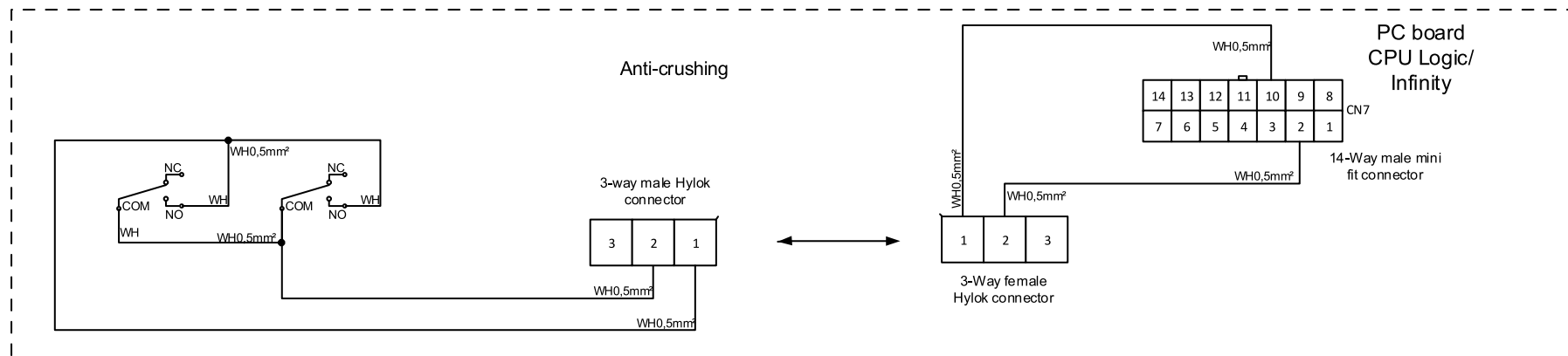
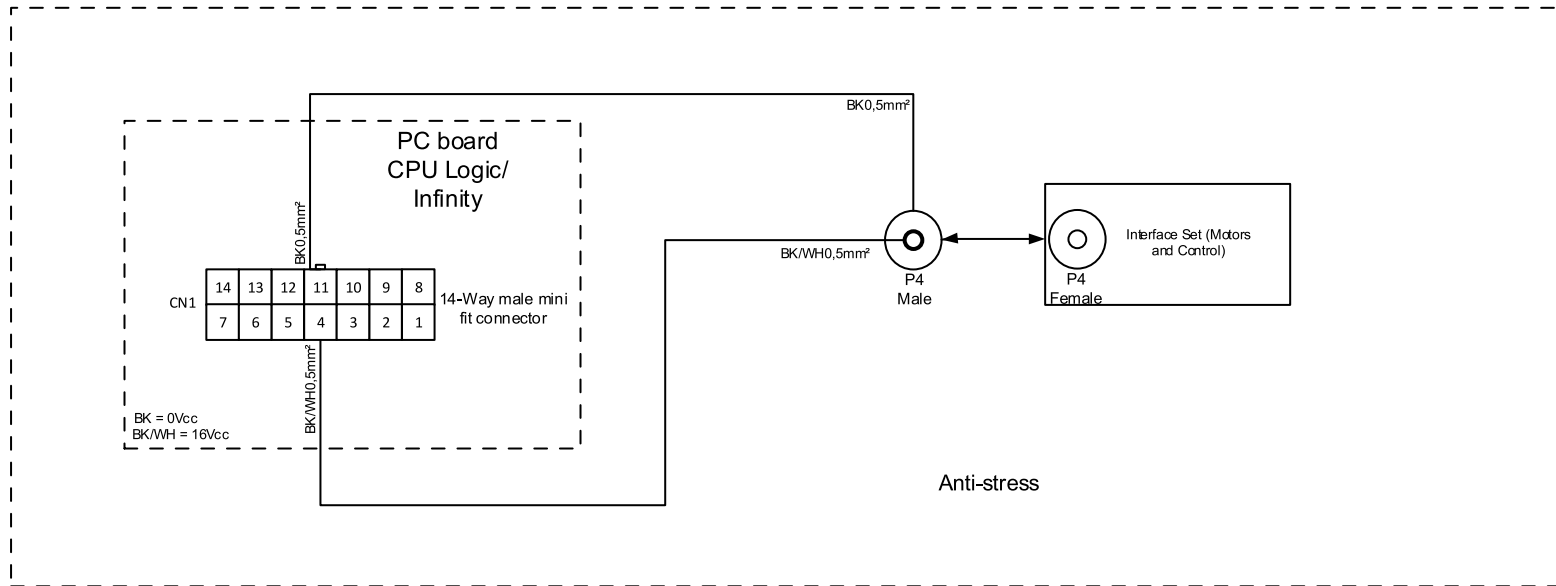

Color Legend	
Black	BK
Red	RD
Blue	BU
Green	GN
White	WH
Brown	BN
Violet	VT
Crystal	CR
Orange	OG
Yellow	YE
Pink	PK
Grey	GY
Green/Yellow	GN/YE
Blue/White	BU/WH
Red/White	RD/WH

Anti-stress and Anti-crushing connection
-Optional items according to the equipment configuration grid

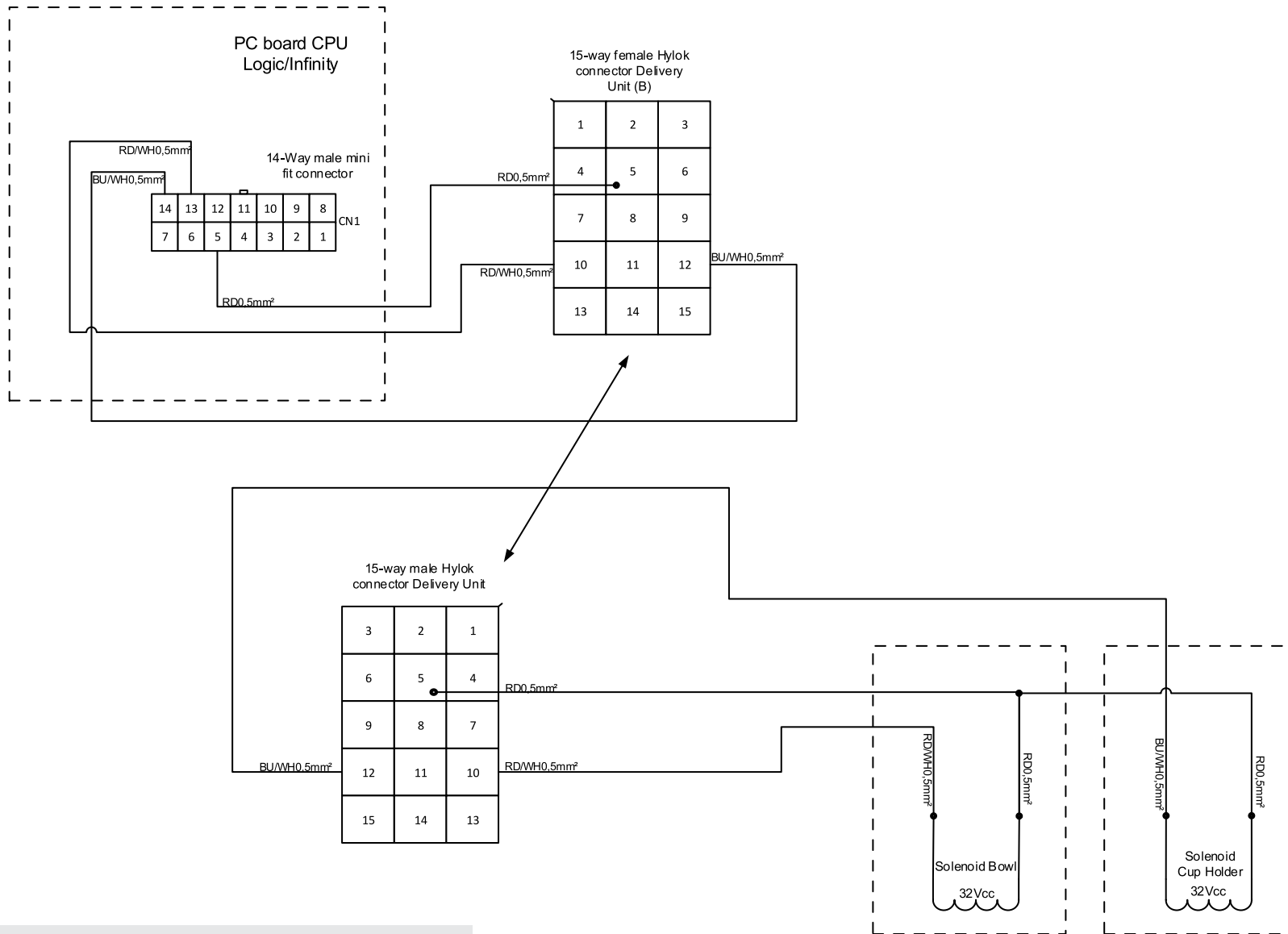

Color Legend	
Black	BK
Red	RD
Blue	BU
Green	GN
White	WH
Brown	BN
Violet	VT
Crystal	CR
Orange	OG
Yellow	YE
Pink	PK
Grey	GY
Green/Yellow	GN/YE
Blue/White	BU/WH
Red/White	RD/WH

Solenoid Bowl Connection, Cup Holder
 -Optional items according to the equipment configuration grid

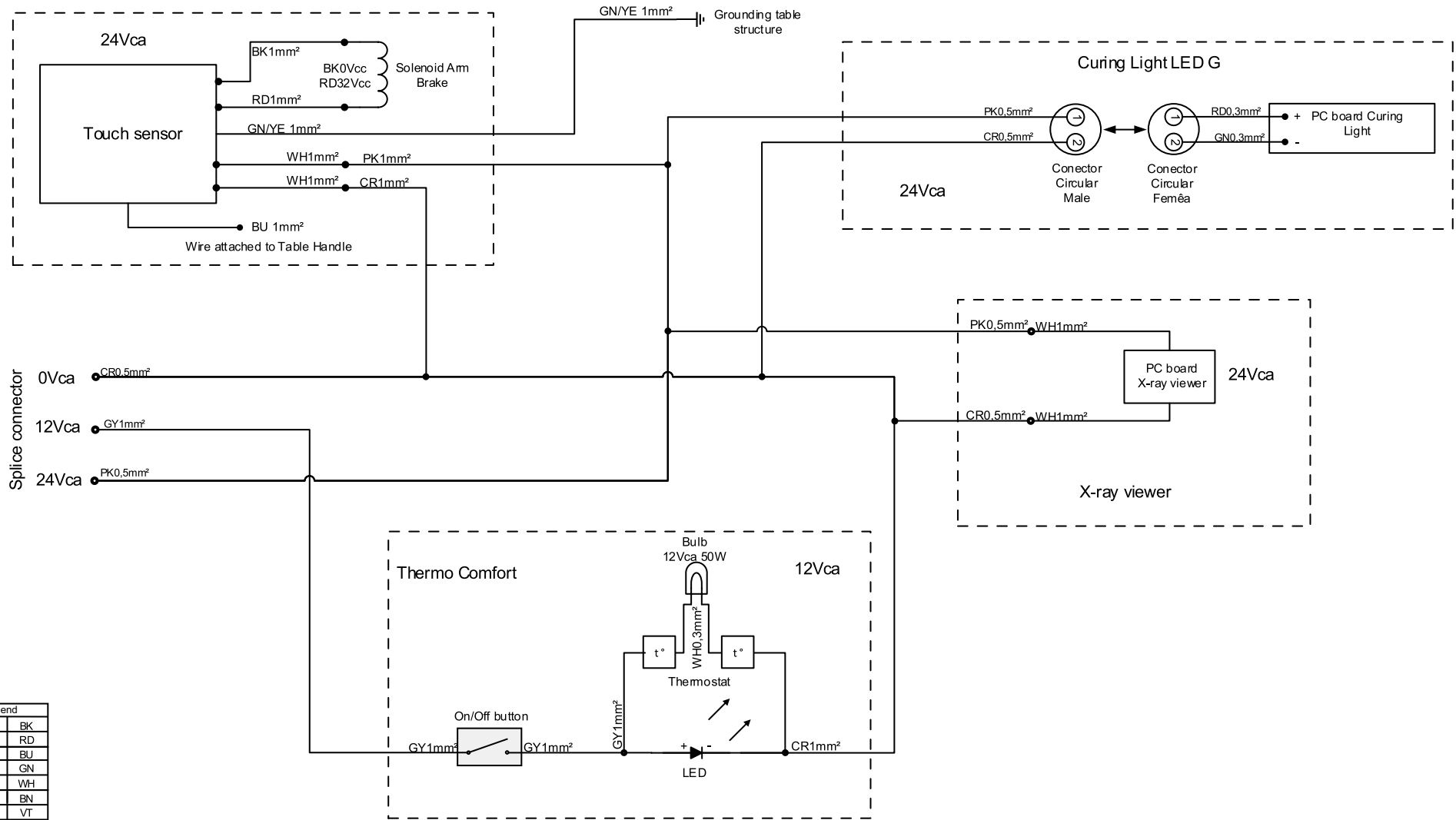

Color Legend	
Black	BK
Red	RD
Blue	BU
Green	GN
White	WH
Brown	BN
Violet	VT
Crystal	CR
Orange	OG
Yellow	YE
Pink	PK
Grey	GY
Green/Yellow	GN/YE
Blue/White	BU/WH
Red/White	RD/WH

Touch sensor connection, Photopolymerizer, X-ray viewer and Thermo Comfort
 -Optional items according to the equipment configuration grid

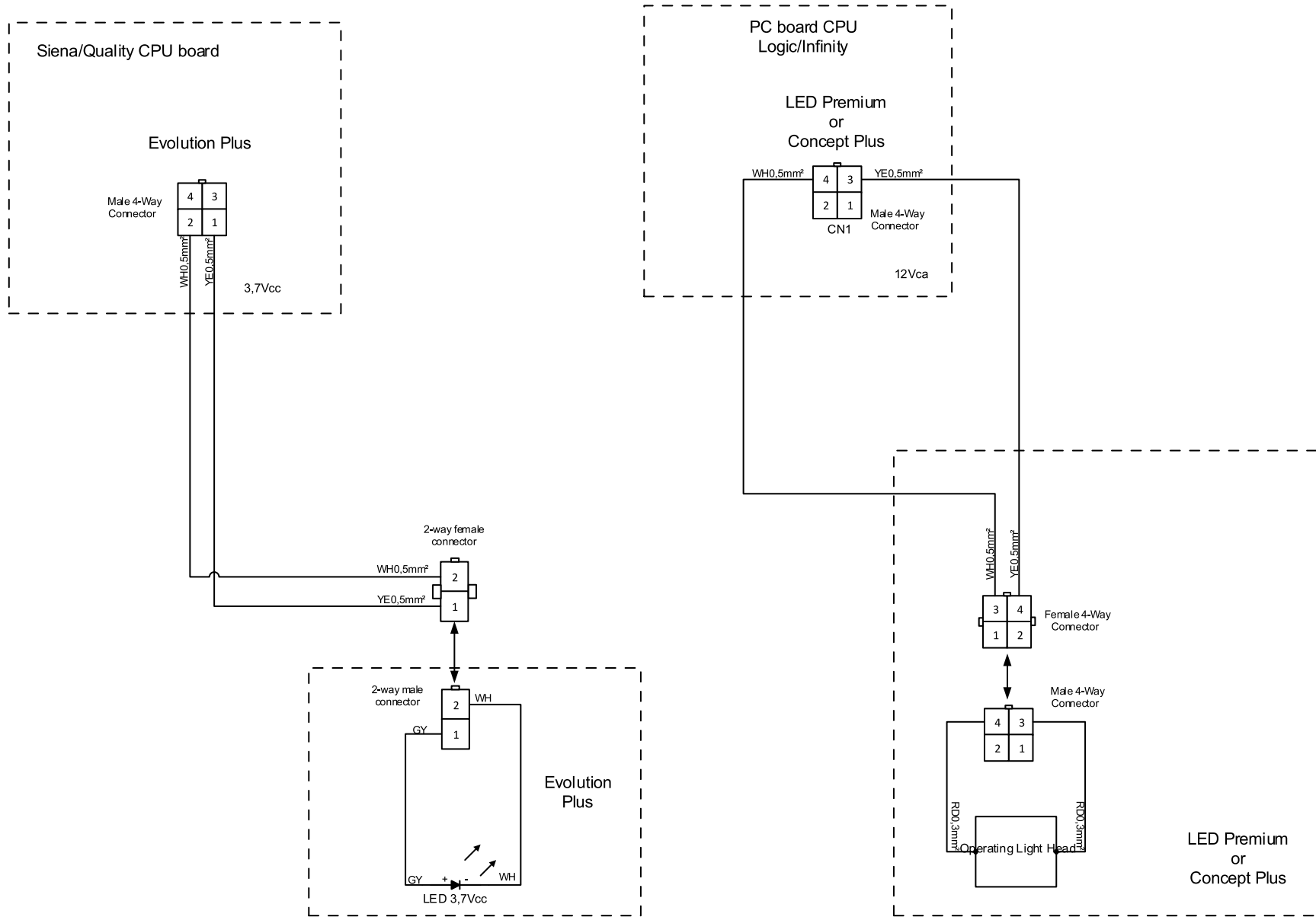

Color Legend	
Black	BK
Red	RD
Blue	BU
Green	GN
White	WH
Brown	BN
Violet	VT
Crystal	CR
Orange	OG
Yellow	YE
Pink	PK
Grey	GY
Green/Yellow	GN/YE
Blue/White	BU/WH
Red/White	RD/WH

Connection Operating Light
 -Optional items according to the equipment configuration grid

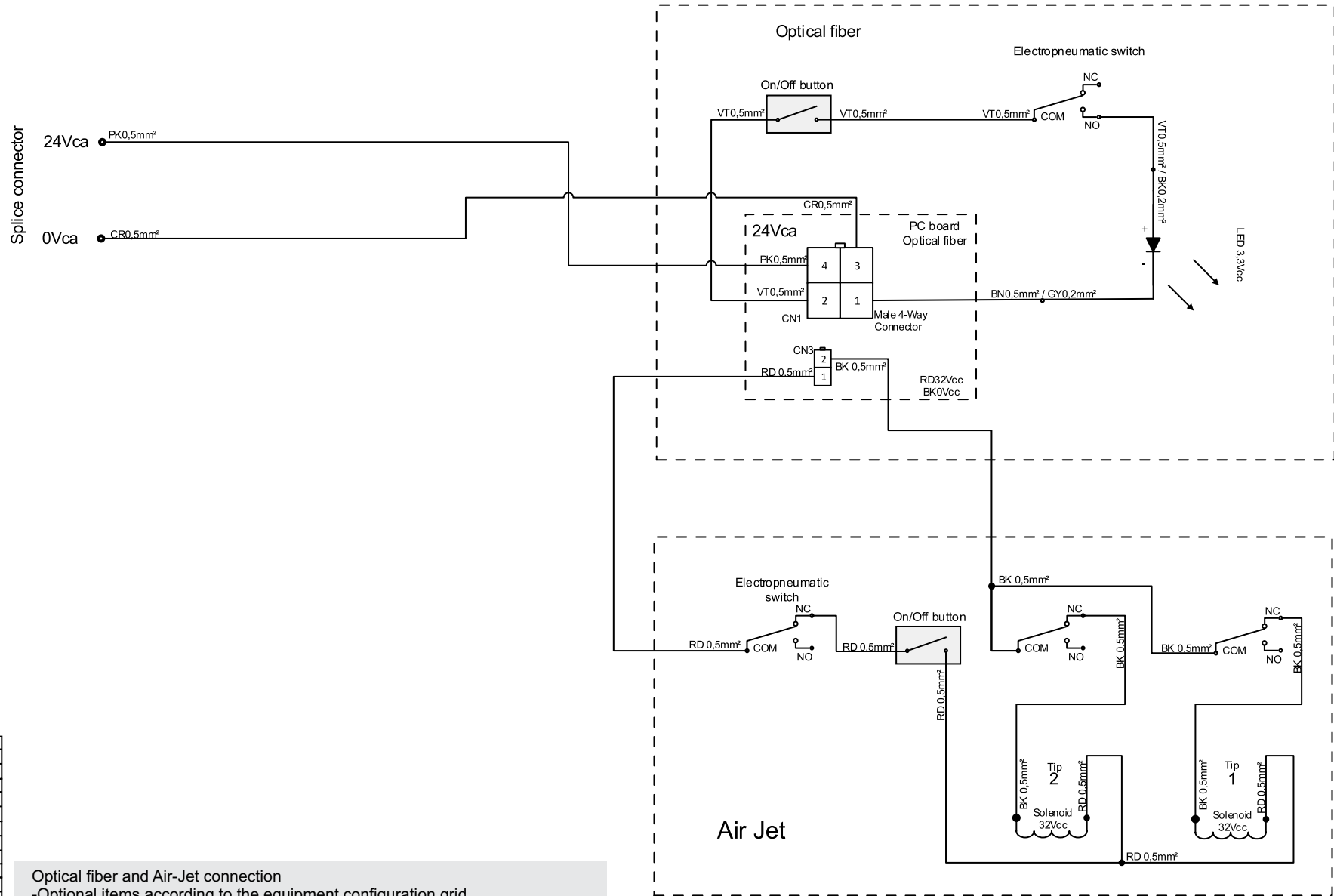

Color Legend	
Black	BK
Red	RD
Blue	BU
Green	GN
White	WH
Brown	BN
Violet	VT
Crystal	CR
Orange	OG
Yellow	YE
Pink	PK
Grey	GY
Green/Yellow	GN/YE
Blue/White	BU/WH
Red/White	RD/WH

Optical fiber and Air-Jet connection
 -Optional items according to the equipment configuration grid
 -Only with Air-Jet, use a PC Optical fiber CN3 output board.
 -If requested Optical fiber and Air-Jet, do not use the On/Off button of Optical fiber

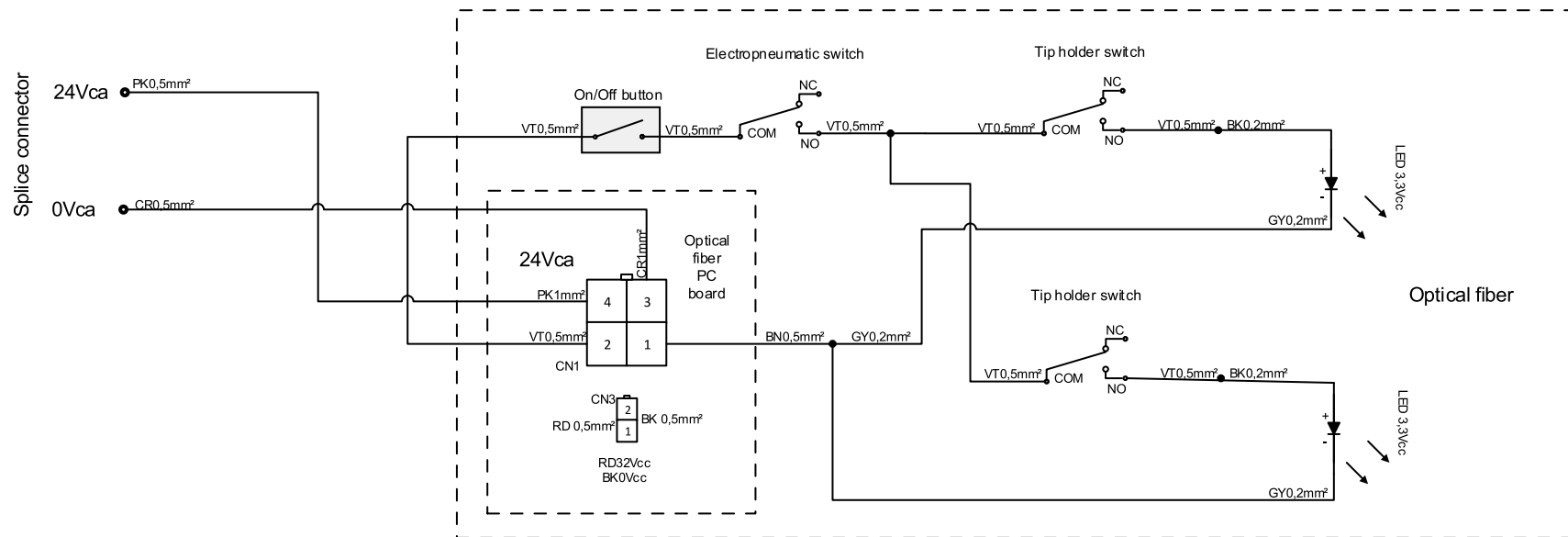

Color Legend	
Black	BK
Red	RD
Blue	BU
Green	GN
White	WH
Brown	BN
Violet	VT
Crystal	CR
Orange	OG
Yellow	YE
Pink	PK
Grey	GY
Green/Yellow	GN/YE
Blue/White	BU/WH
Red/White	RD/WH

Connection with two Optical fiber
 -Optional items according to the equipment configuration grid
 -With Air-Jet only, use one CN3 PC Fiber-Optic output board.
 -If requested Optical fiber and Air-Jet, do not use the On/Off button of Optical fiber

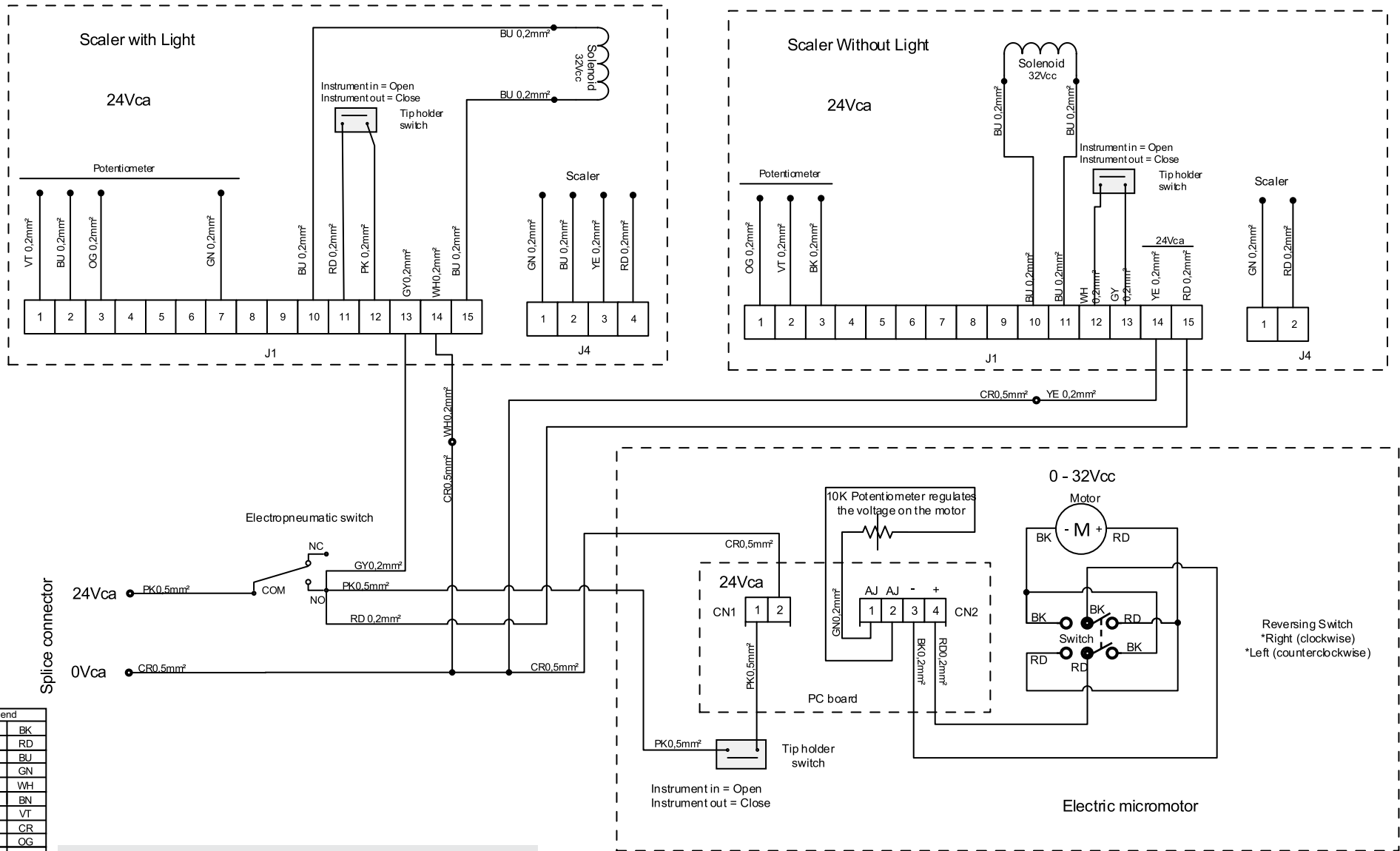

Scaler and Electric Micromotor Connection
-Optional items according to the equipment configuration grid

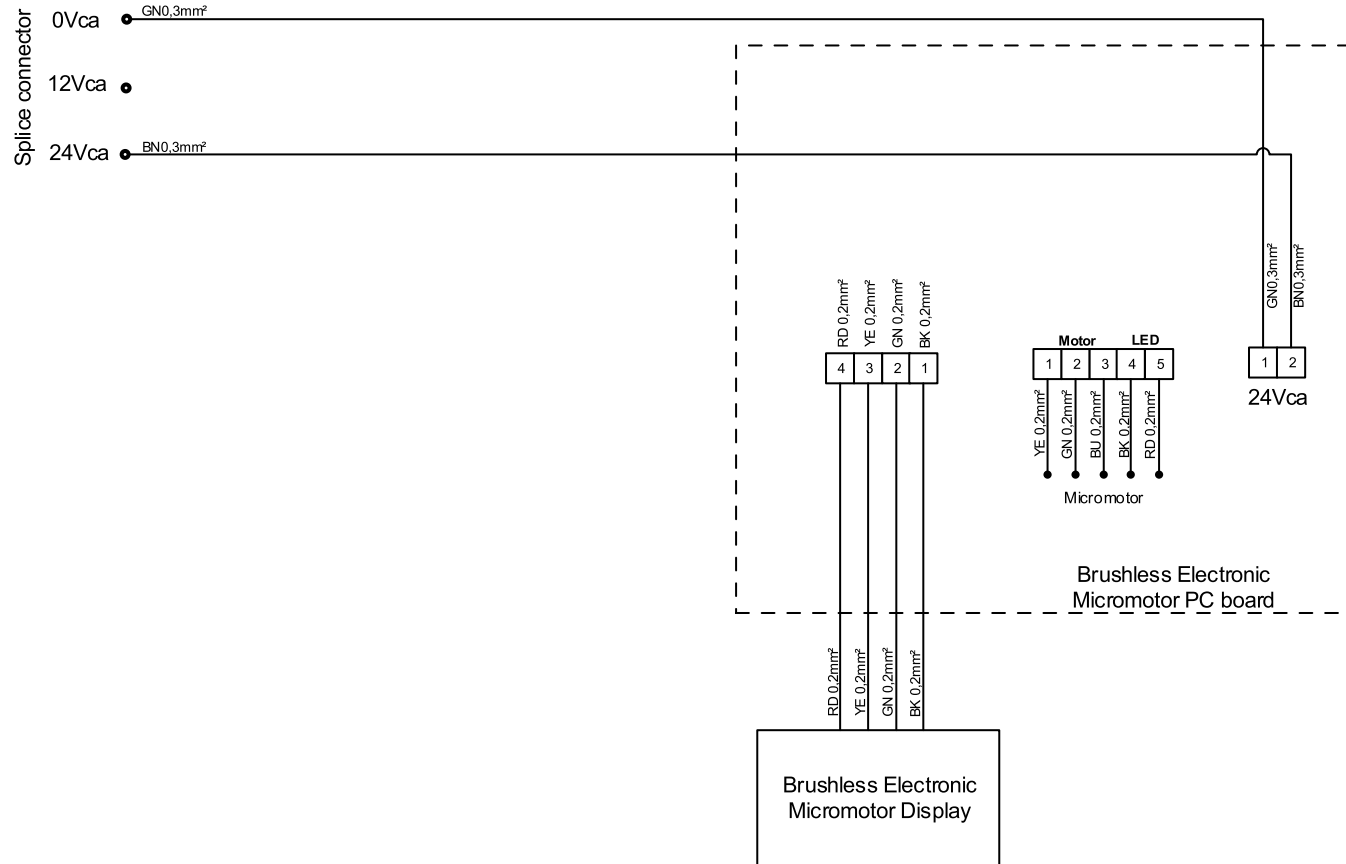

Color Legend	
Black	BK
Red	RD
Blue	BU
Green	GN
White	WH
Brown	BN
Violet	VT
Crystal	CR
Orange	OG
Yellow	YE
Pink	PK
Grey	GY
Green/Yellow	GN/YE
Blue/White	BU/WH
Red/White	RD/WH

Brushless electronic Micromotor connection
 -Optionals according to the configuration grid of the equipment

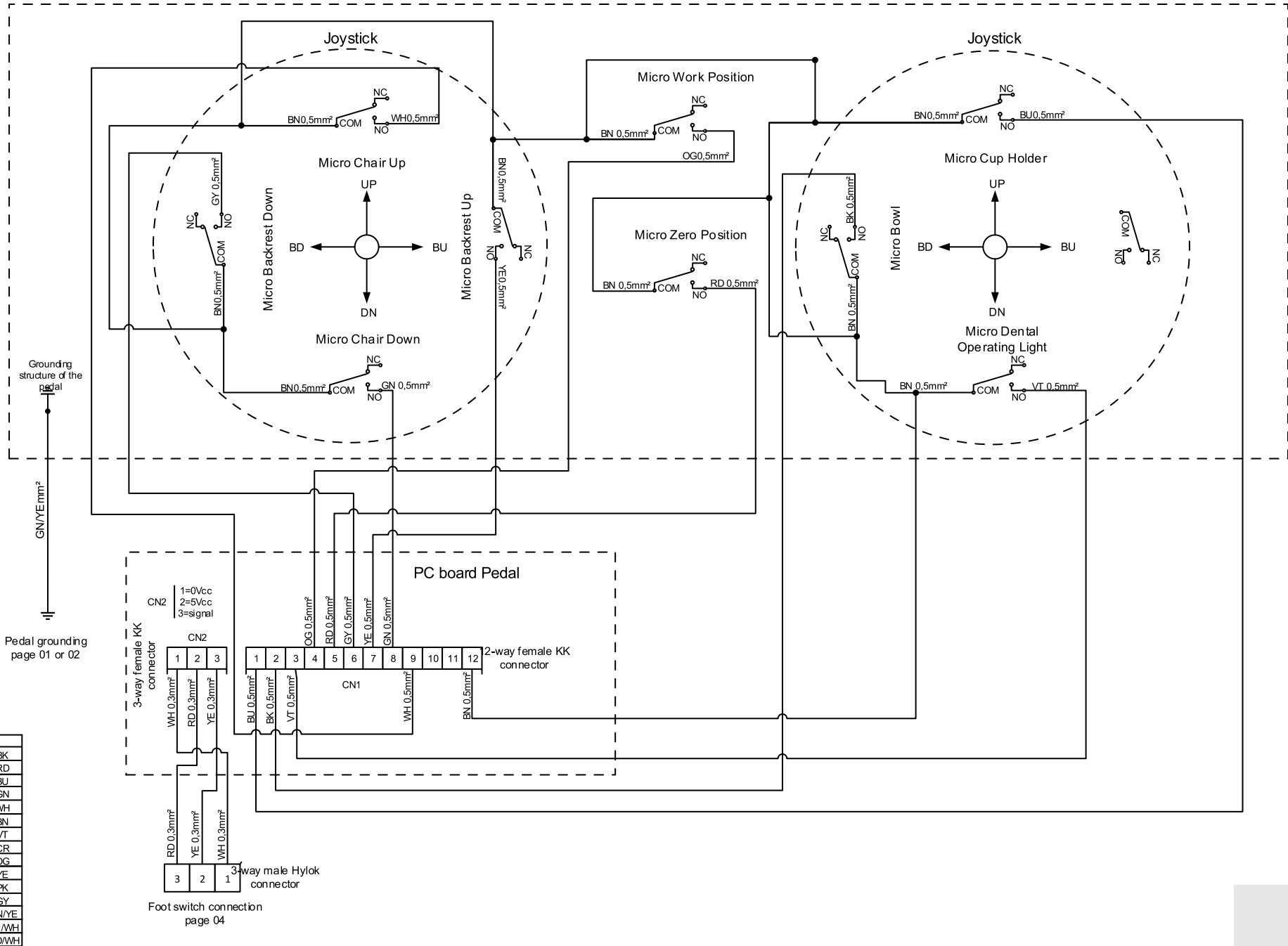

Pedal

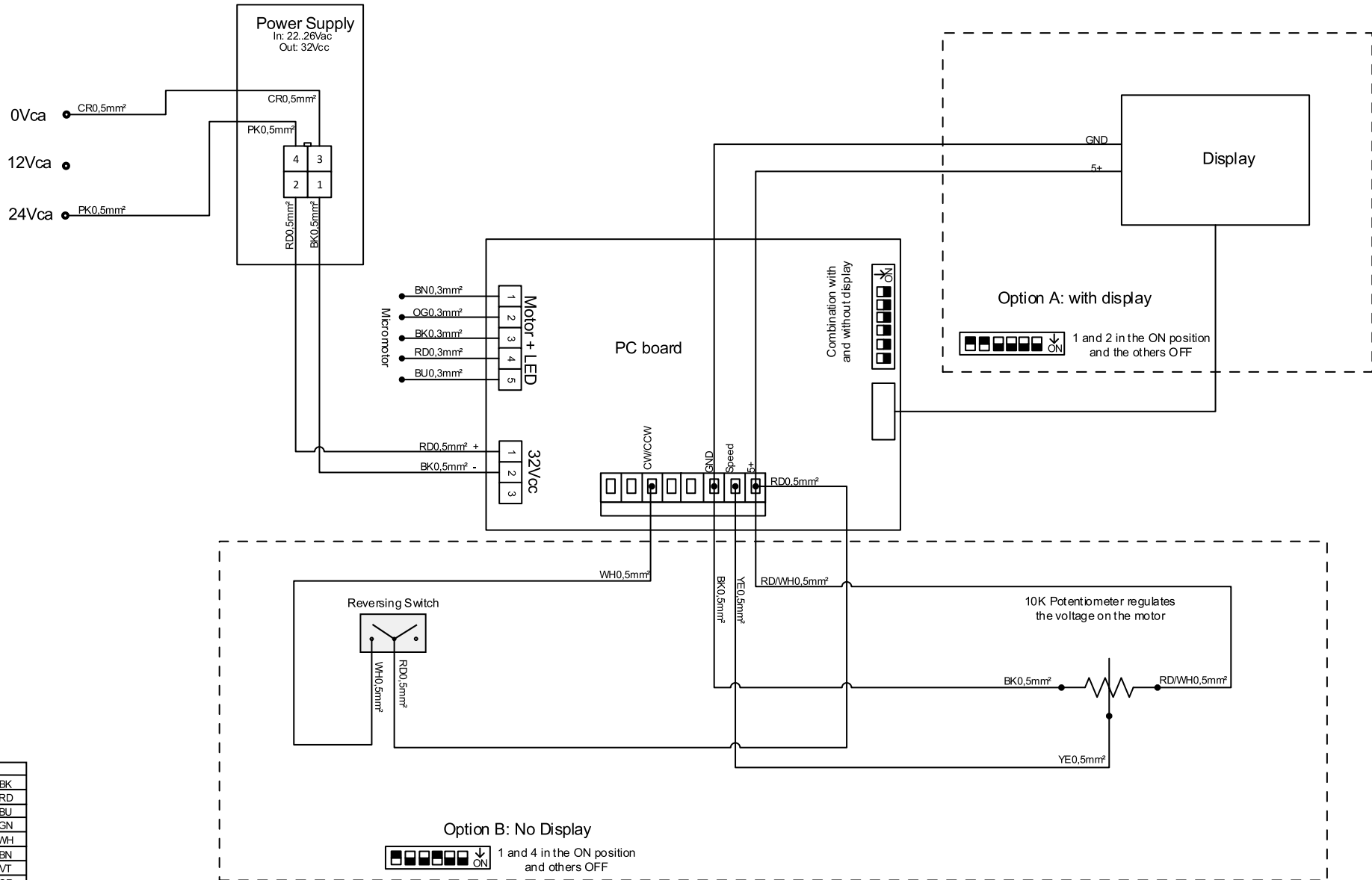

Color Legend	
Black	BK
Red	RD
Blue	BU
Green	GN
White	WH
Brown	BN
Violet	VT
Crystal	CR
Orange	OG
Yellow	YE
Pink	PK
Grey	GY
Green/Yellow	GN/YE
Blue/White	BU/WH
Red/White	RD/WH

Micromotor Bien Air connection
 Connection Micromotor Bien Air -Optional items according to
 the equipment configuration grid

Transformer Input Electrical Diagram
page 01 of 02

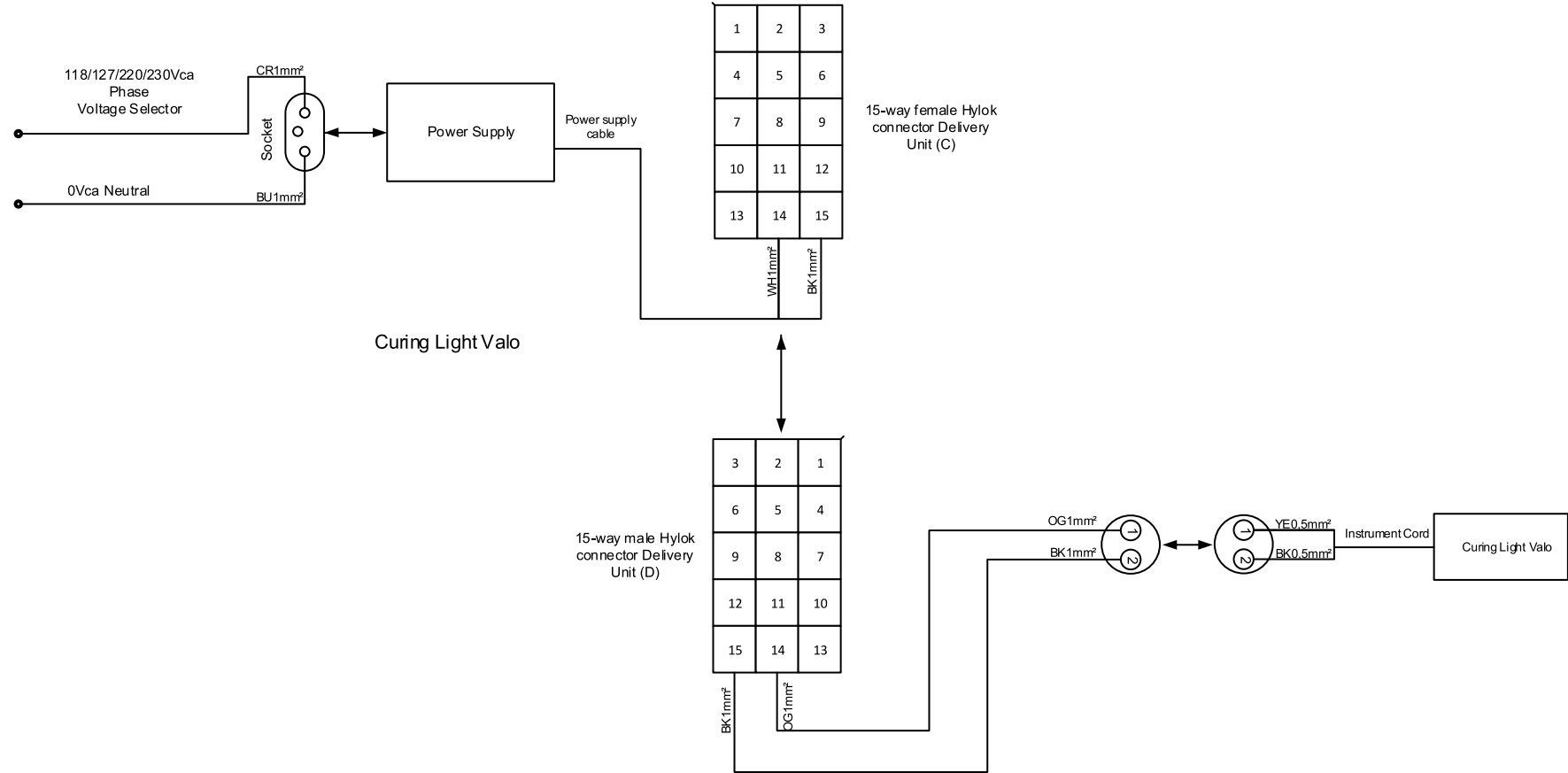

Curing Light Valo

15-way female Hylok connector Delivery Unit (C)

15-way male Hylok connector Delivery Unit (D)

Curing Light Valo

Color Legend	
Black	BK
Red	RD
Blue	BU
Green	GN
White	WH
Brown	BN
Violet	VT
Crystal	CR
Orange	OG
Yellow	YE
Pink	PK
Grey	GY
Green/Yellow	GN/YE
Blue/White	BU/WH
Red/White	RD/WH

Connection Curing Light Valo
-Optional items according to the equipment configuration grid

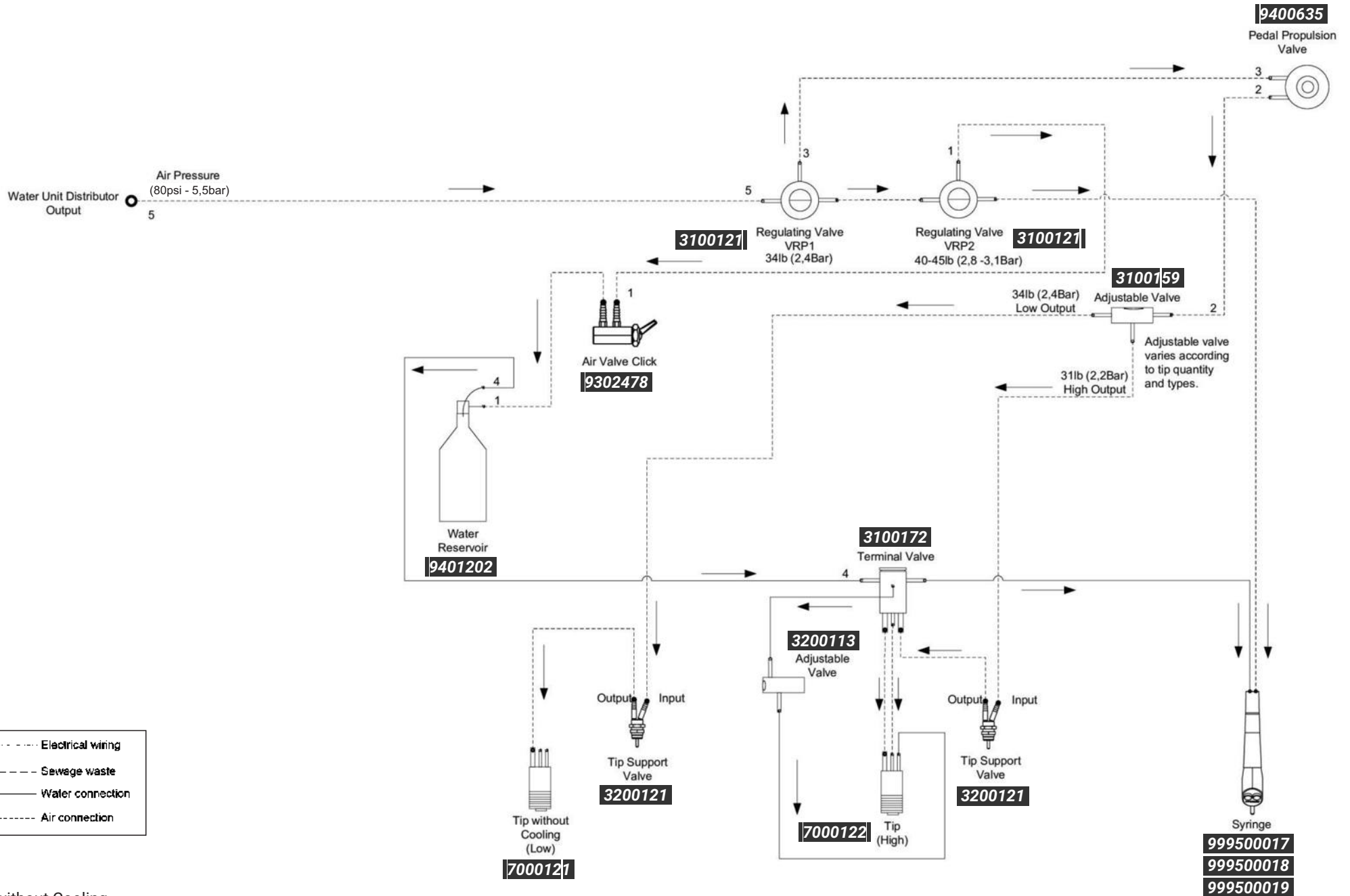

1.3
Low without Cooling

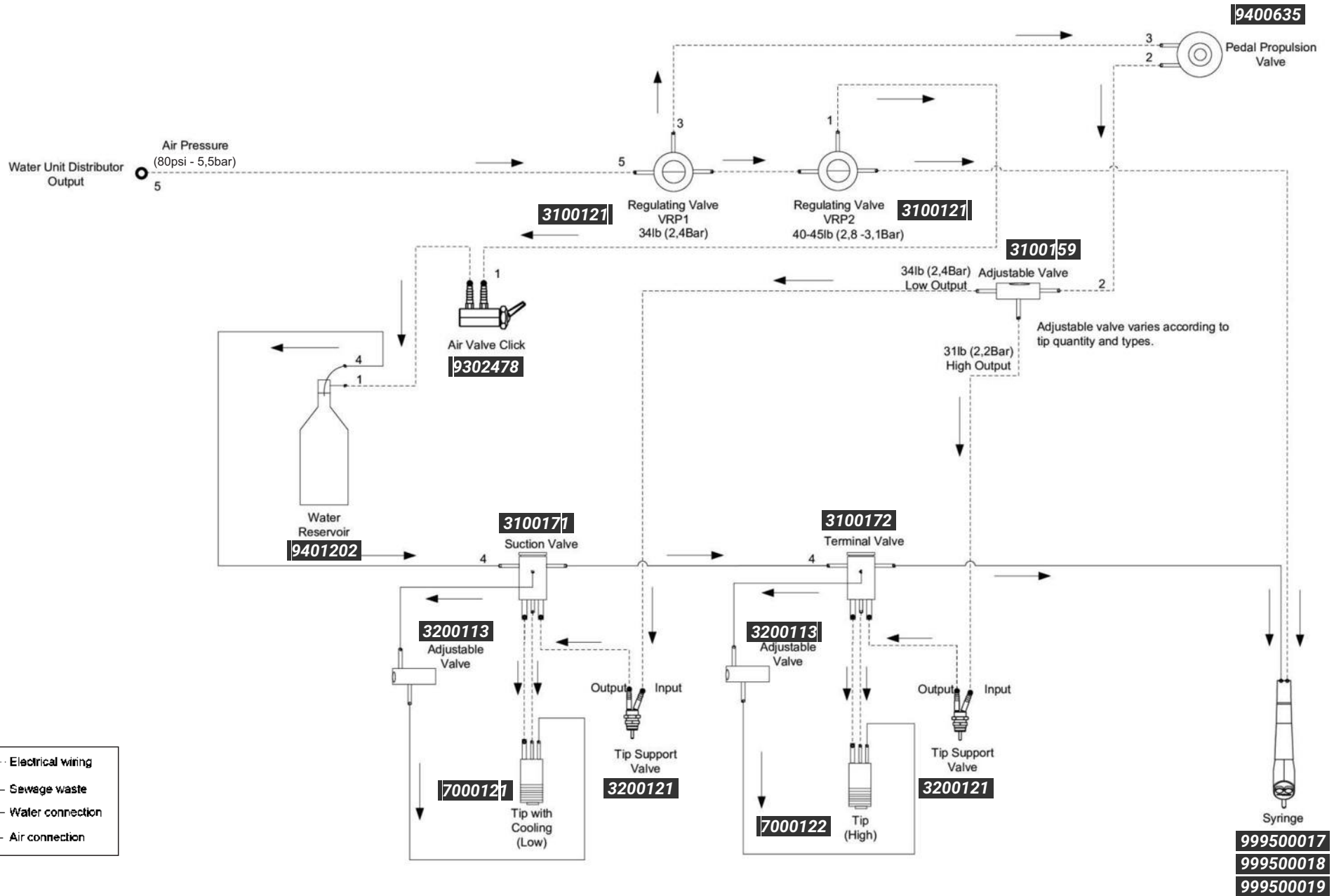

1.3
Low with Cooling

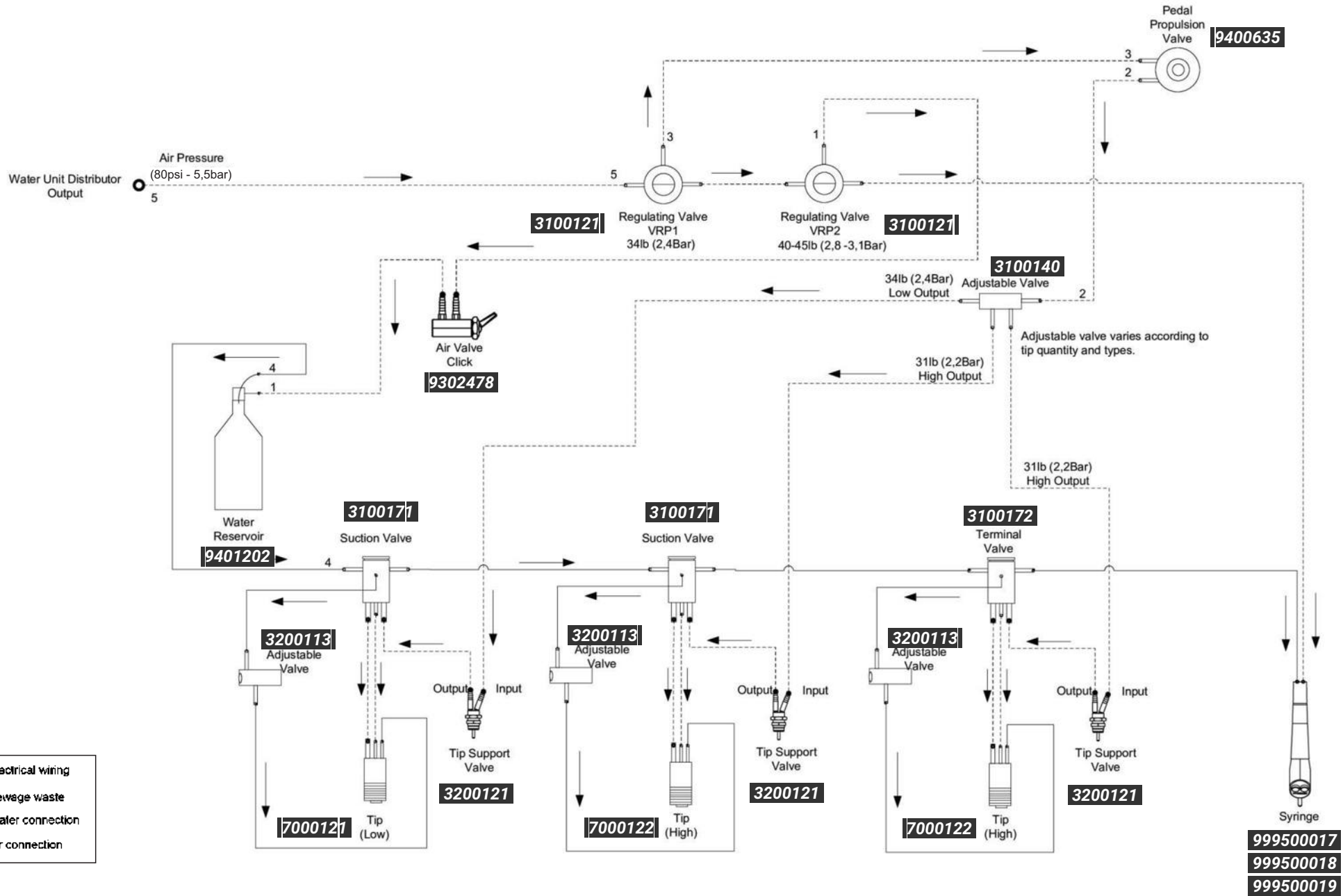

1.4
Syringe, High, High, Low

1.5

Syringe, High, High, Low, Low

Electrical wiring
 Sewage waste
 Water connection
 Air connection

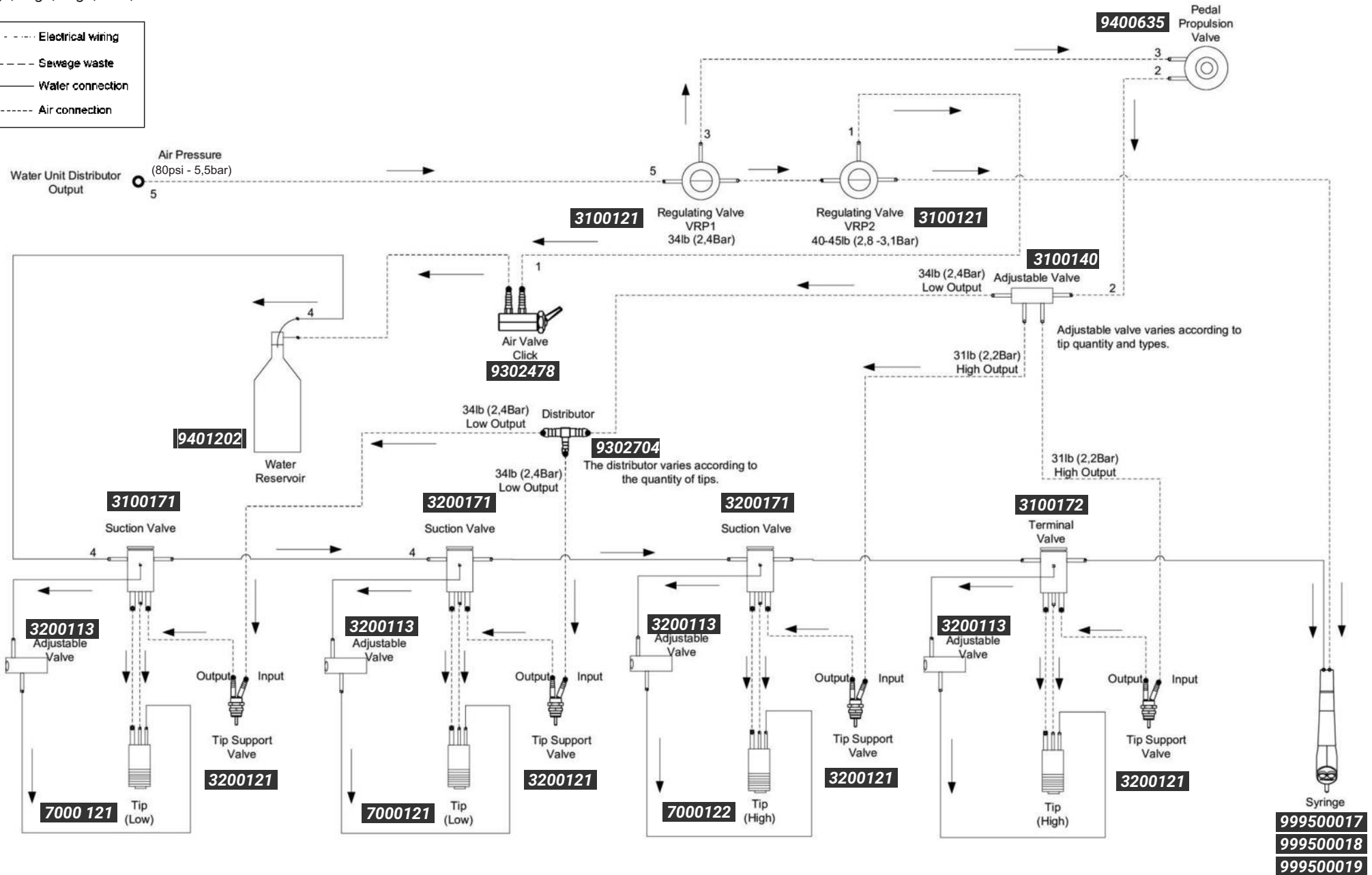

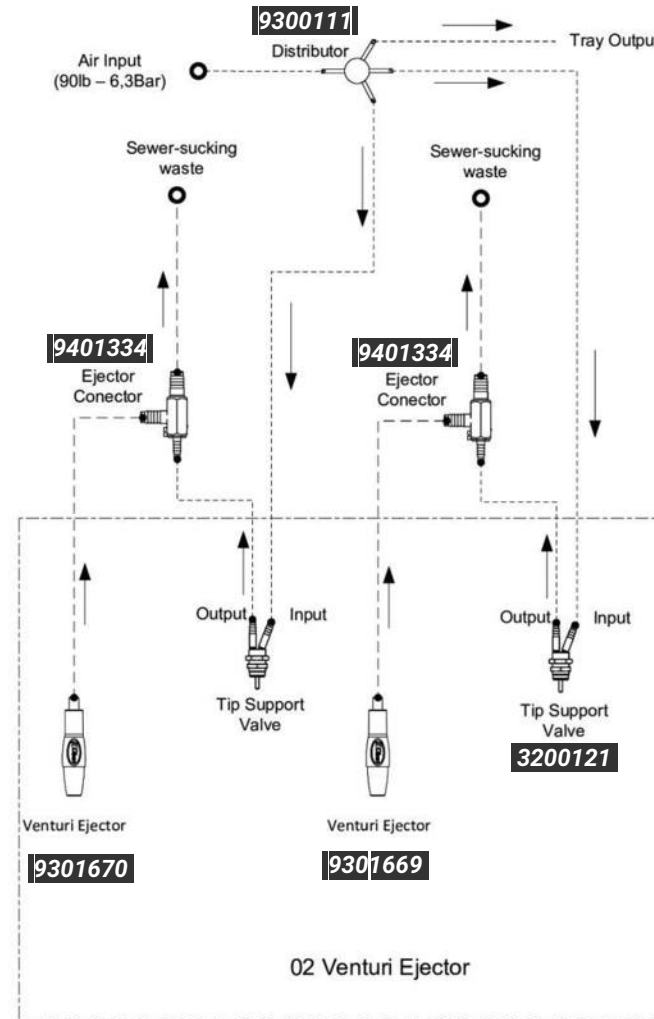
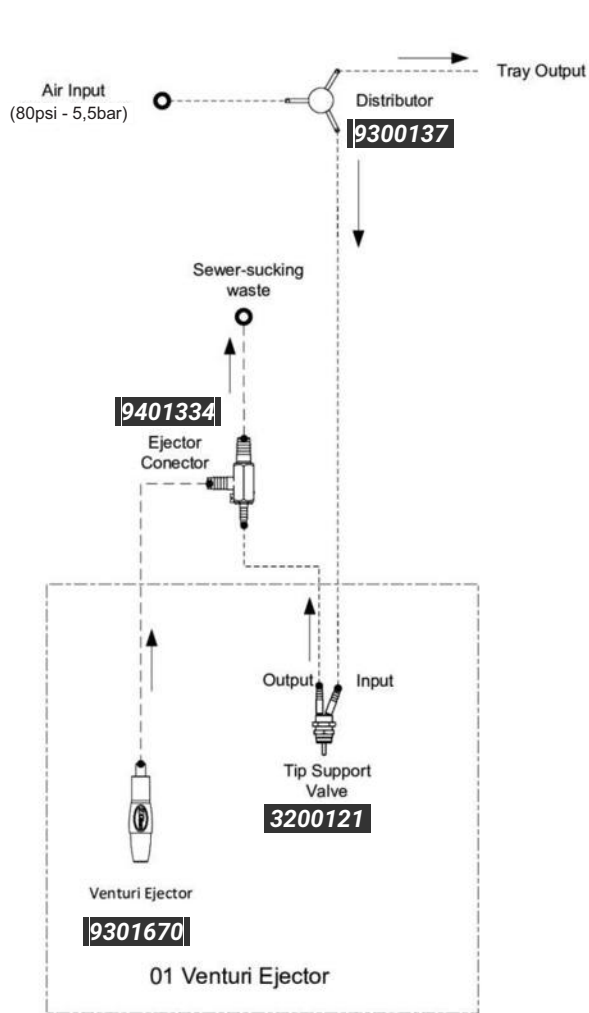

- Electrical wiring
- Sewage waste
- Water connection
- Air connection

WATER UNIT I

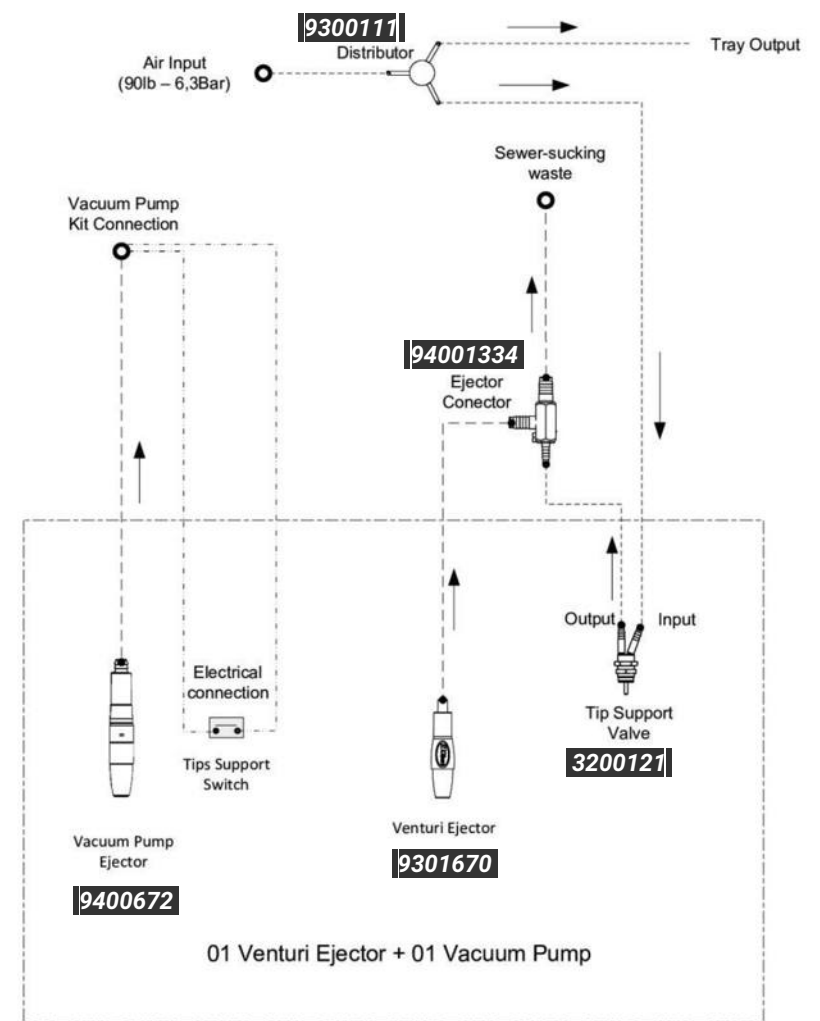
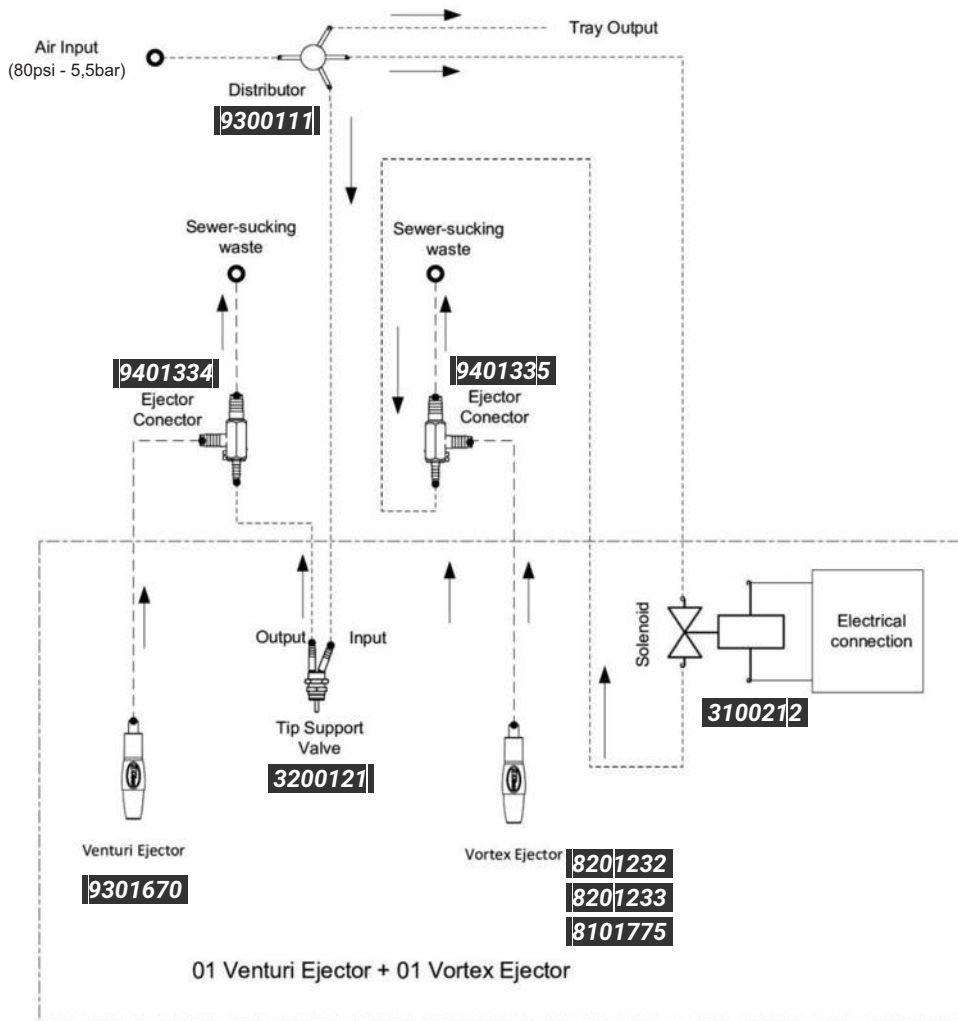

- Electrical wiring
- Sewage waste
- Water connection
- Air connection

WATER UNIT II

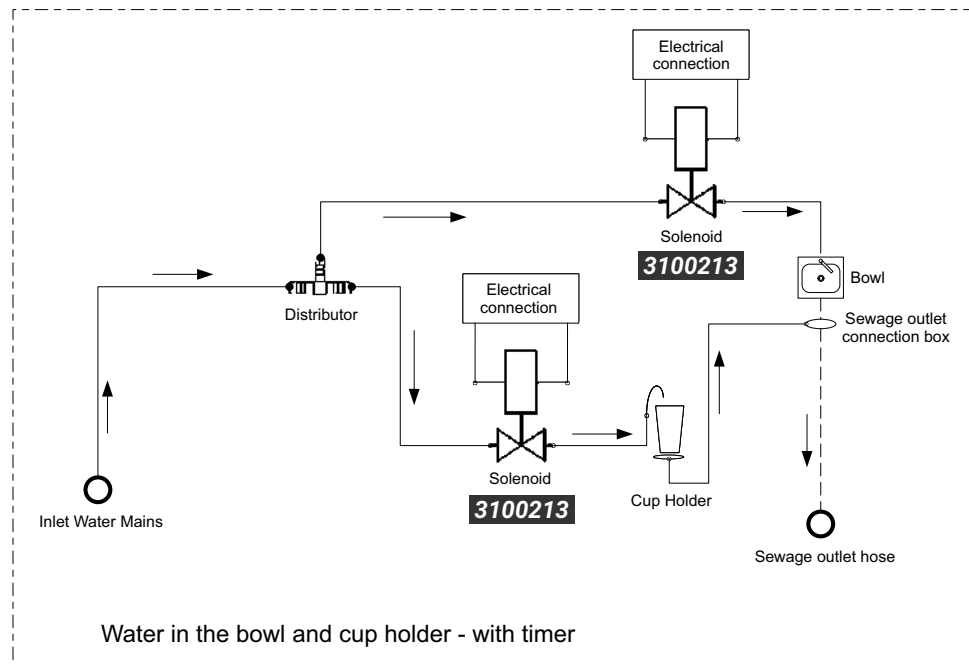
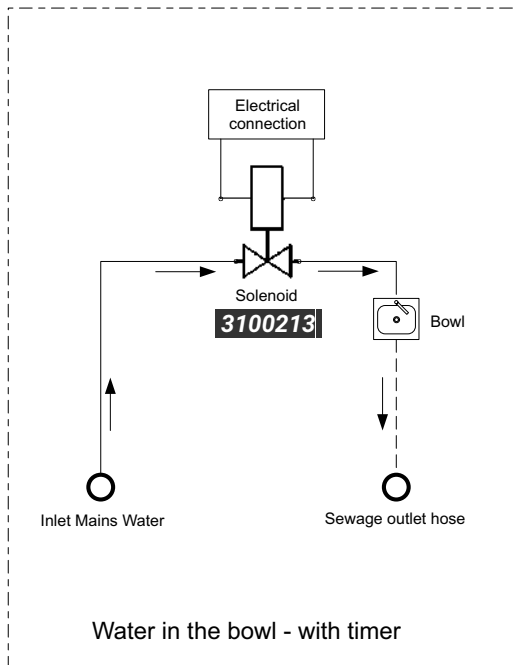
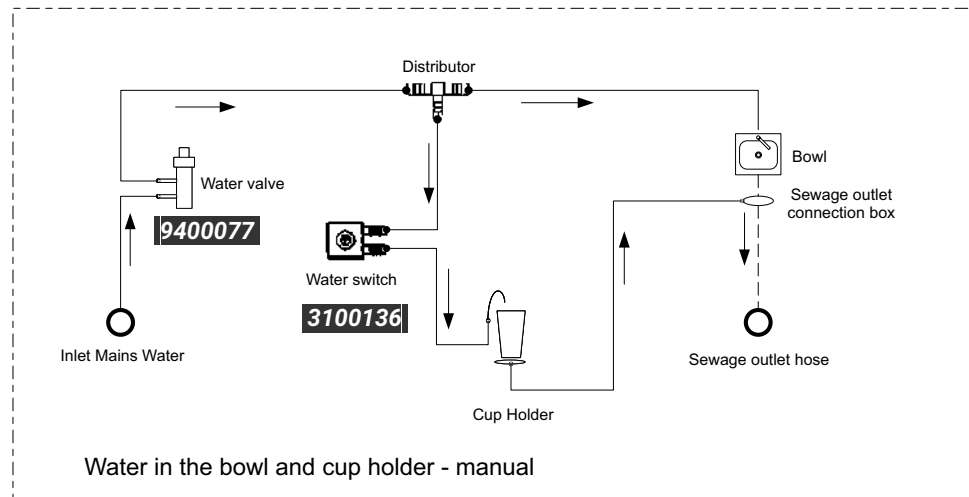
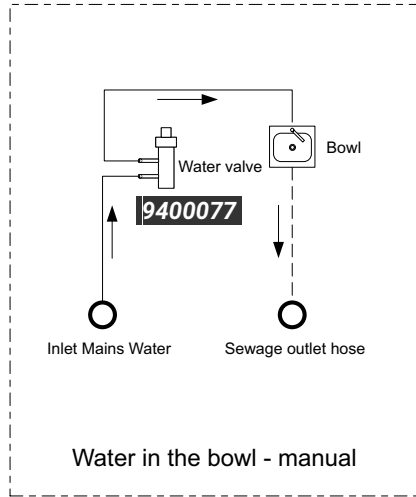

- Electrical wiring
- Sewage waste
- Water connection
- Air connection

WATER UNIT III

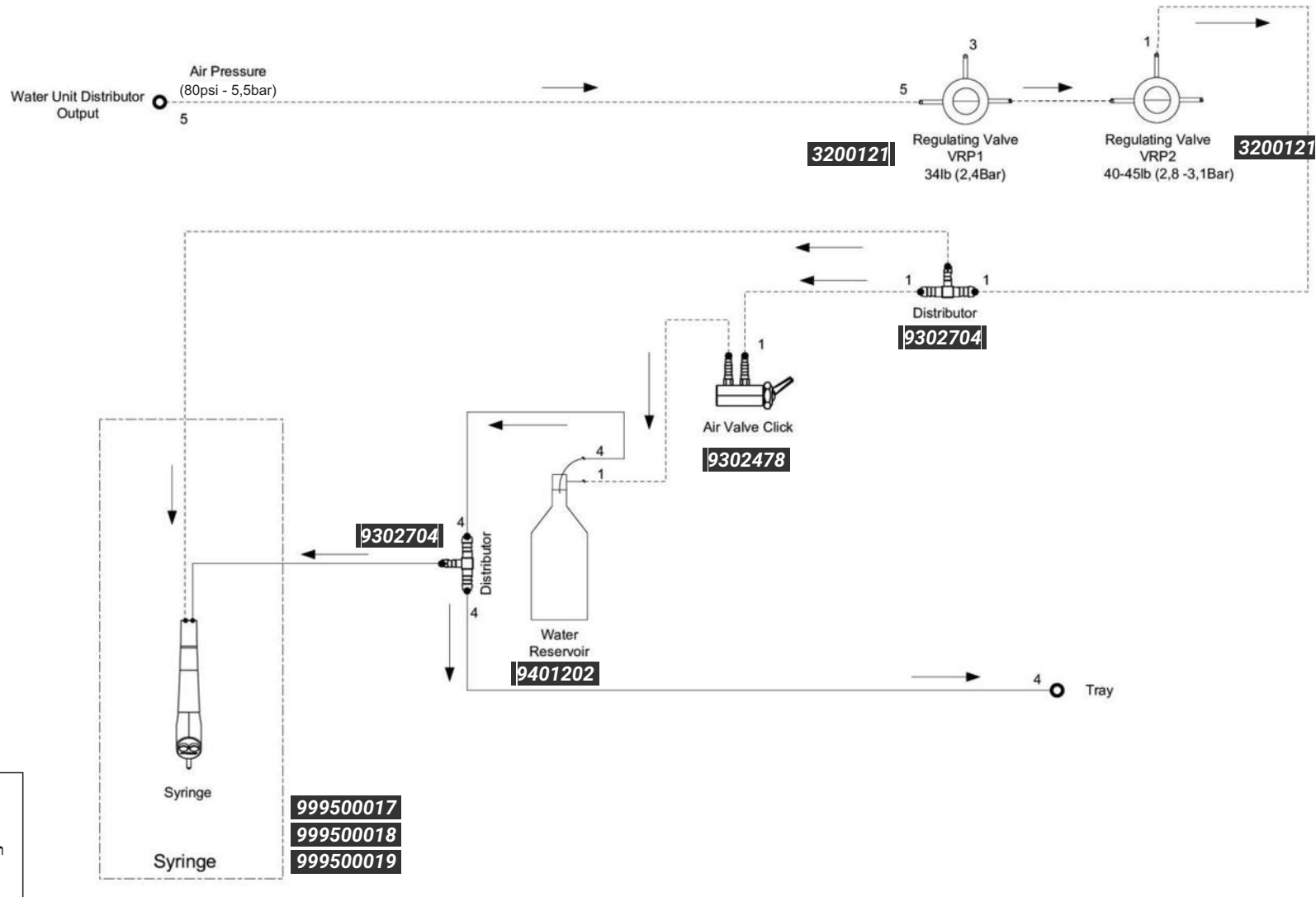

WATER UNIT IV

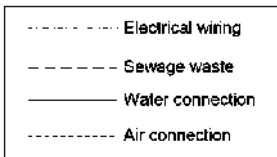
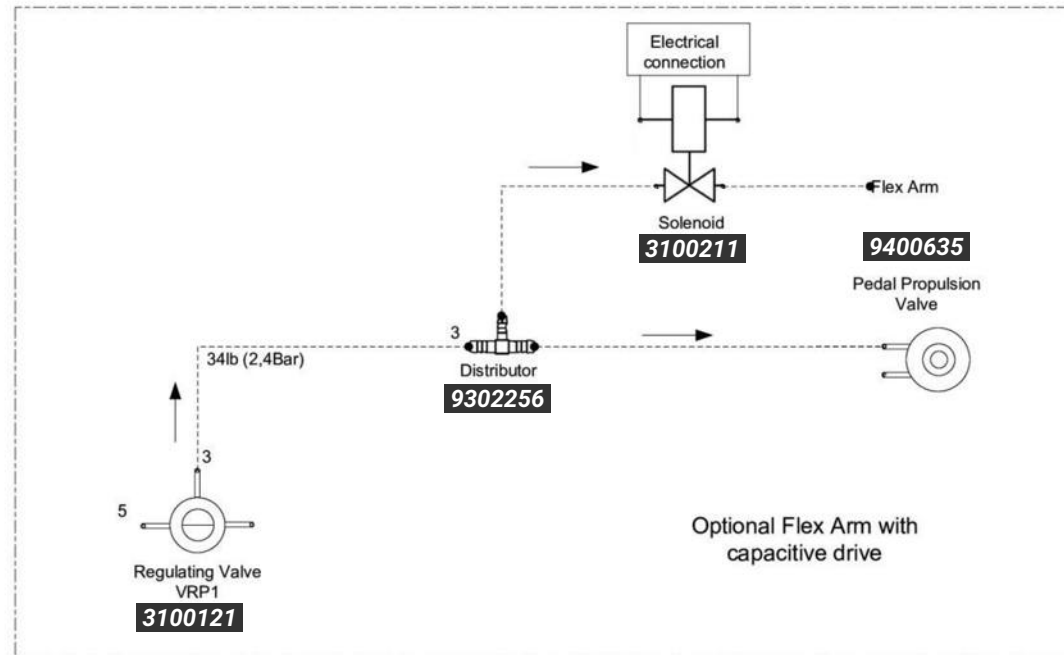
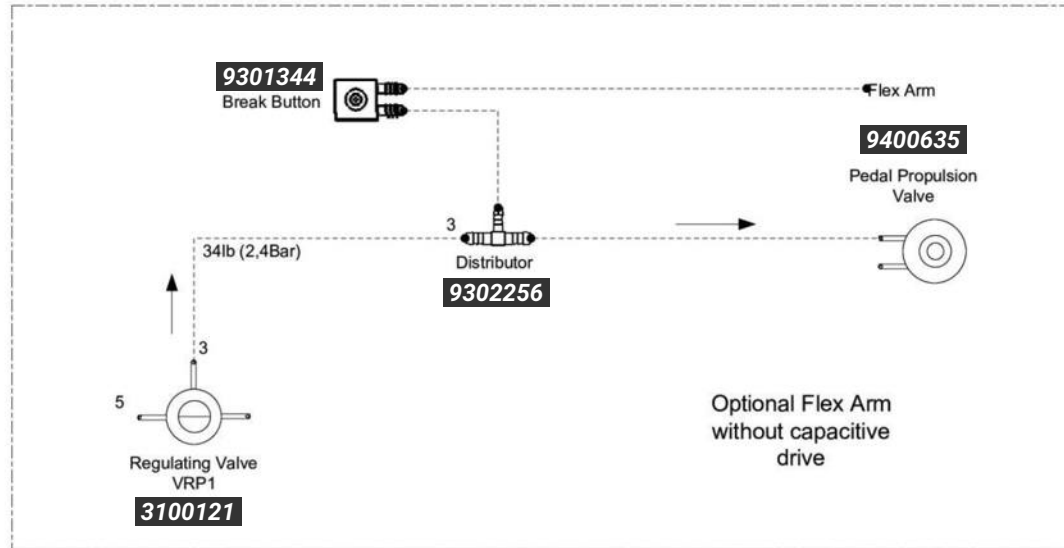

FLEX ARM

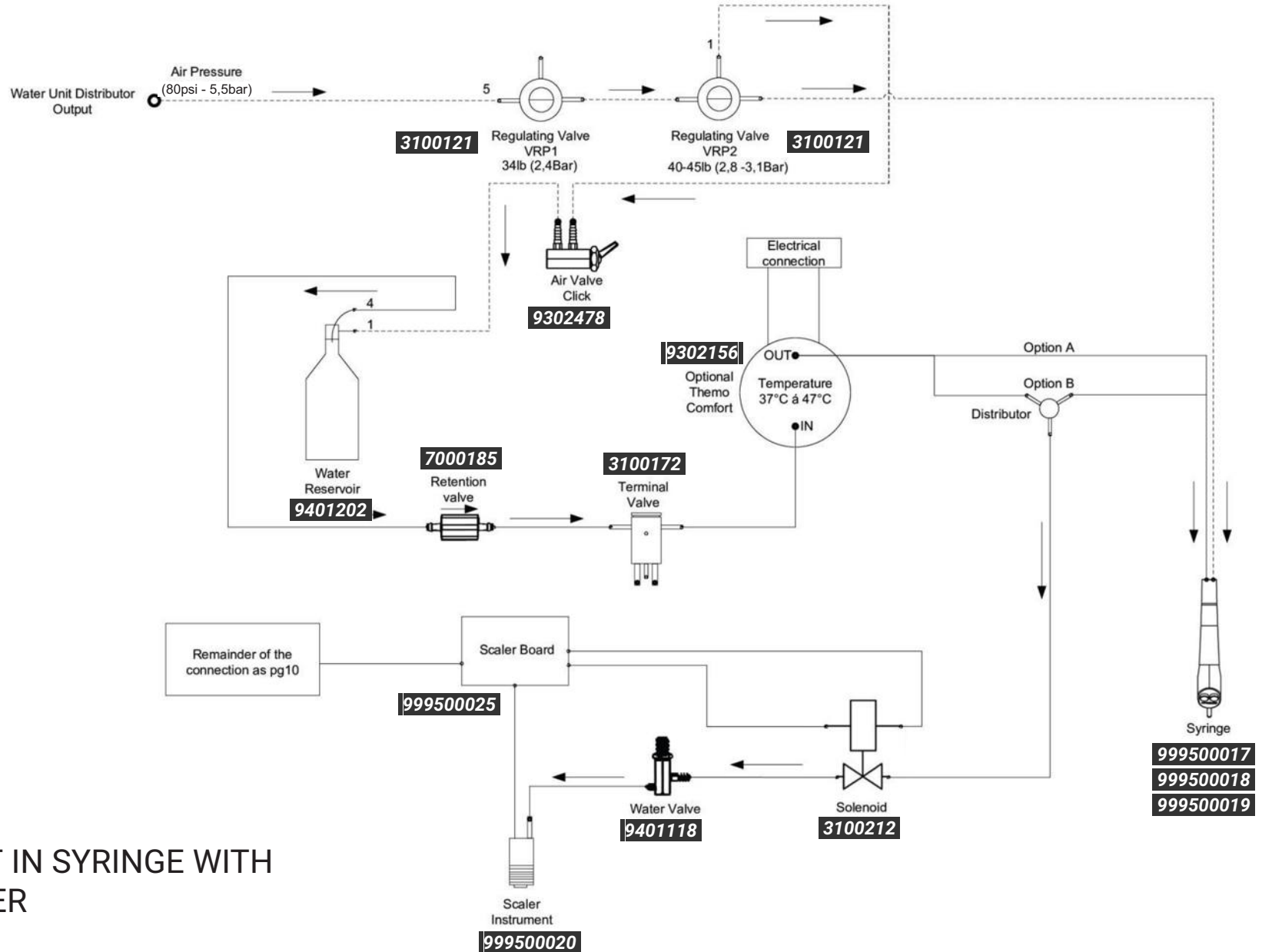

- - - - - Electrical wiring
 - - - - - Sewage waste
 ——— Water connection
 ····· Air connection

THERMO COMFORT IN SYRINGE WITH OPTIONAL IN SCALER

Option A: Syringe only

Option B: With Optional Scaler

All suction valves have been removed for a better view of the wiring diagram.

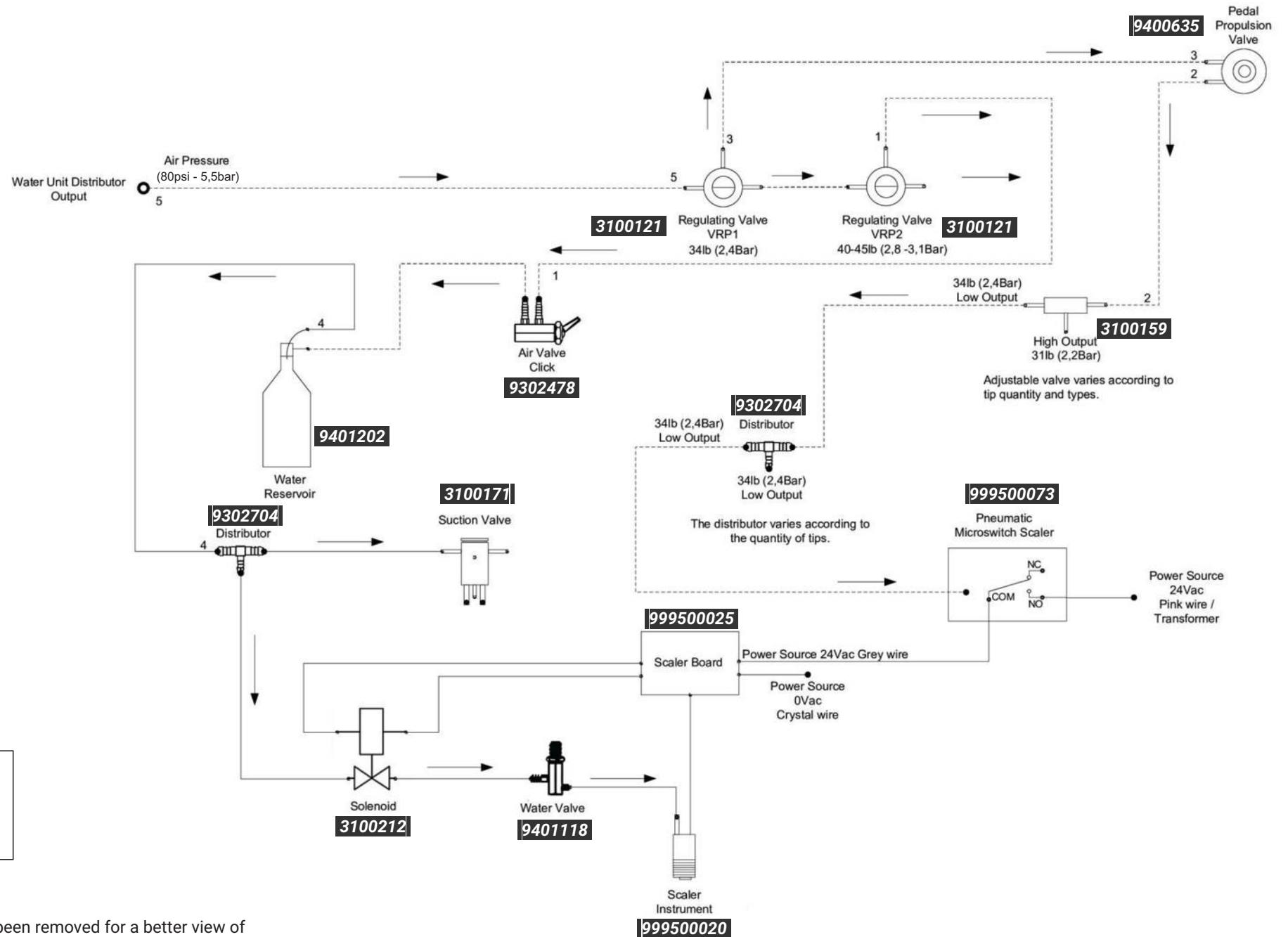

SCALER

All suction valves have been removed for a better view of the wiring diagram.

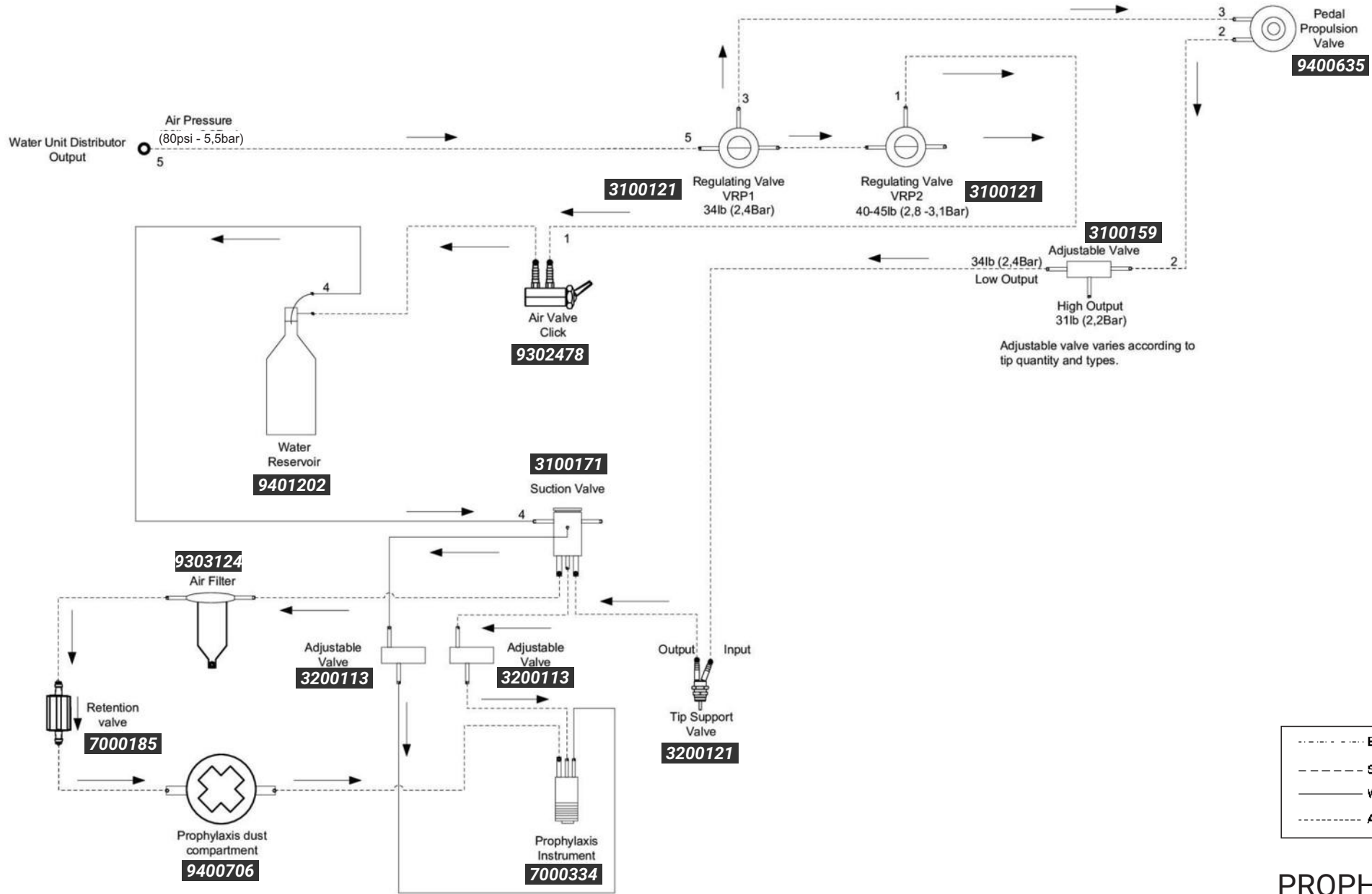

PROPHYLAXIS

All suction valves have been removed for a better view of the wiring diagram.

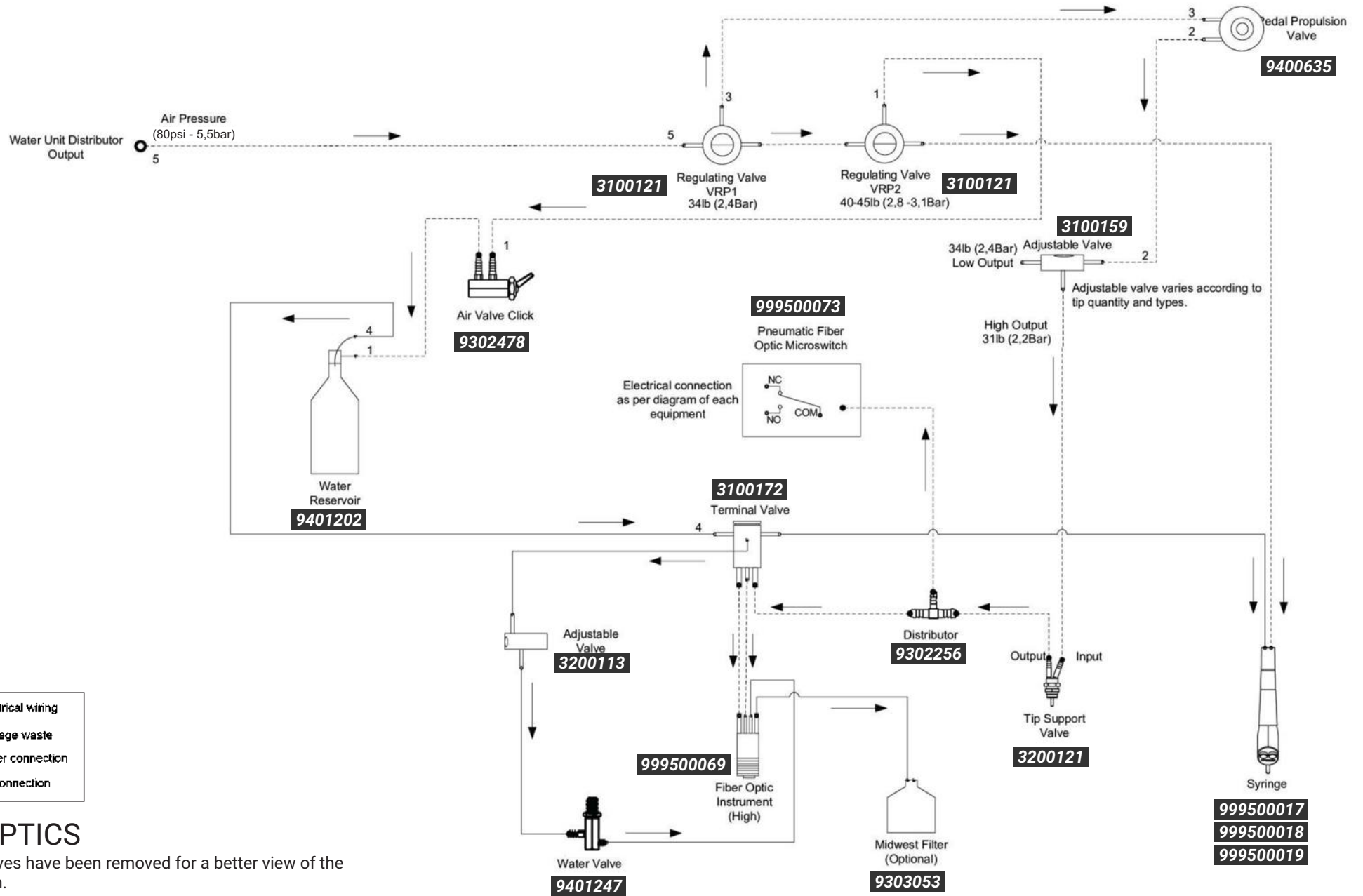

FIBER OPTICS

All suction valves have been removed for a better view of the wiring diagram.

Note: Replicate to the other tips and replace the hose distributor 3 according to the number of tips.

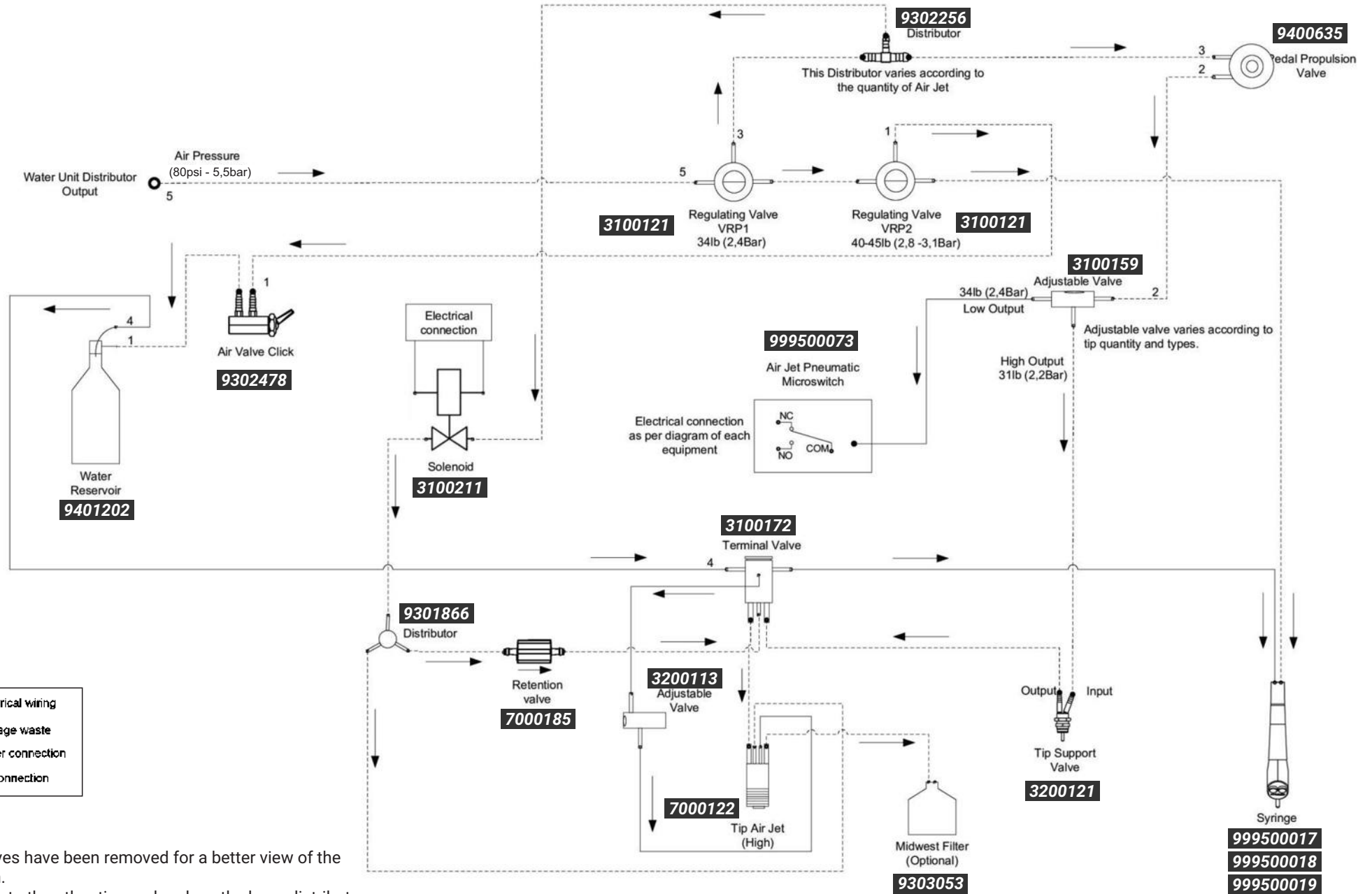

AIR JET

All suction valves have been removed for a better view of the wiring diagram.

Note: Replicate to the other tips and replace the hose distributor 3 according to the number of tips.

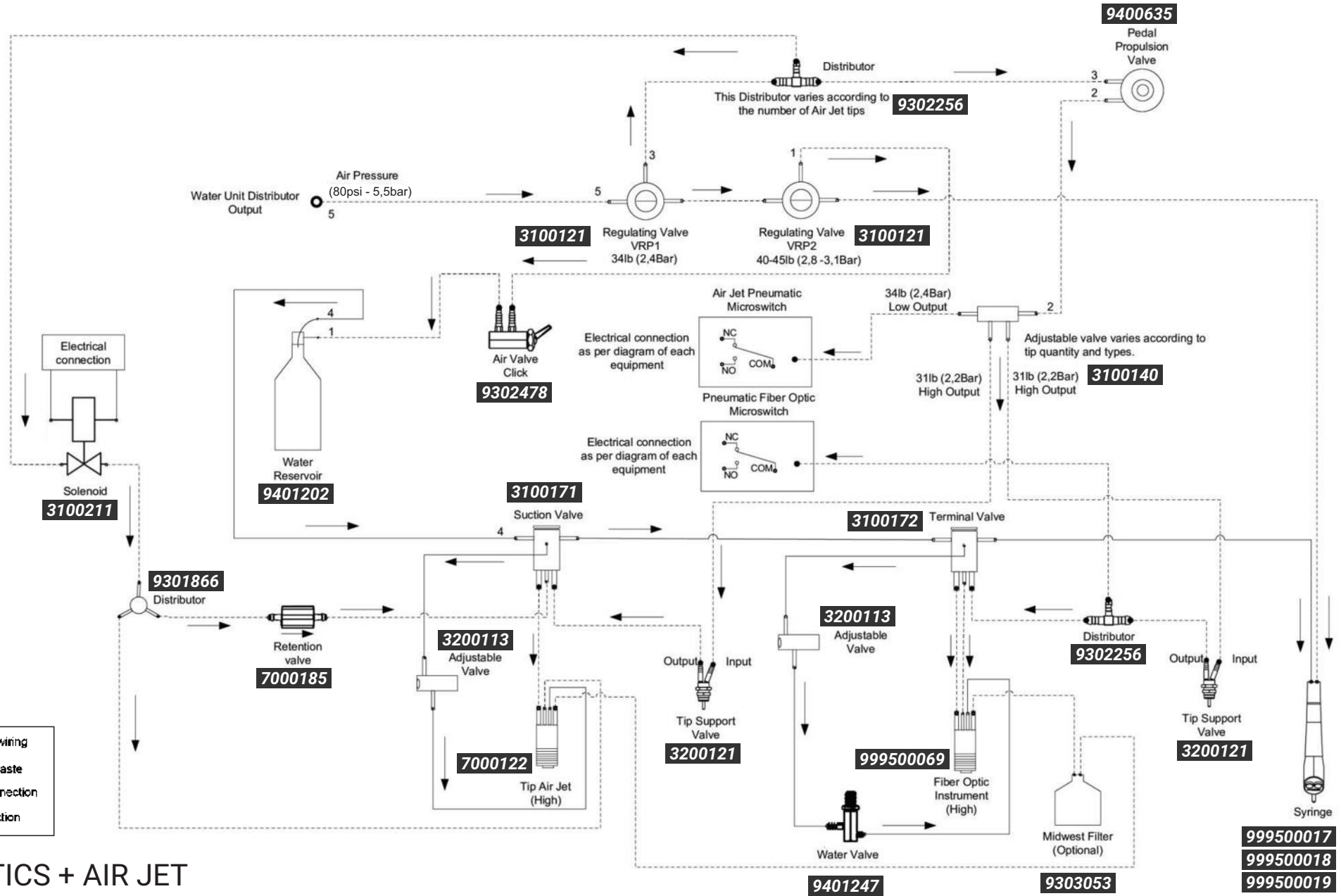

FIBER OPTICS + AIR JET

All suction valves have been removed for a better view of the wiring diagram.
 Note: Replicate to the other tips and replace the hose distributor 3 according to the number of tips.

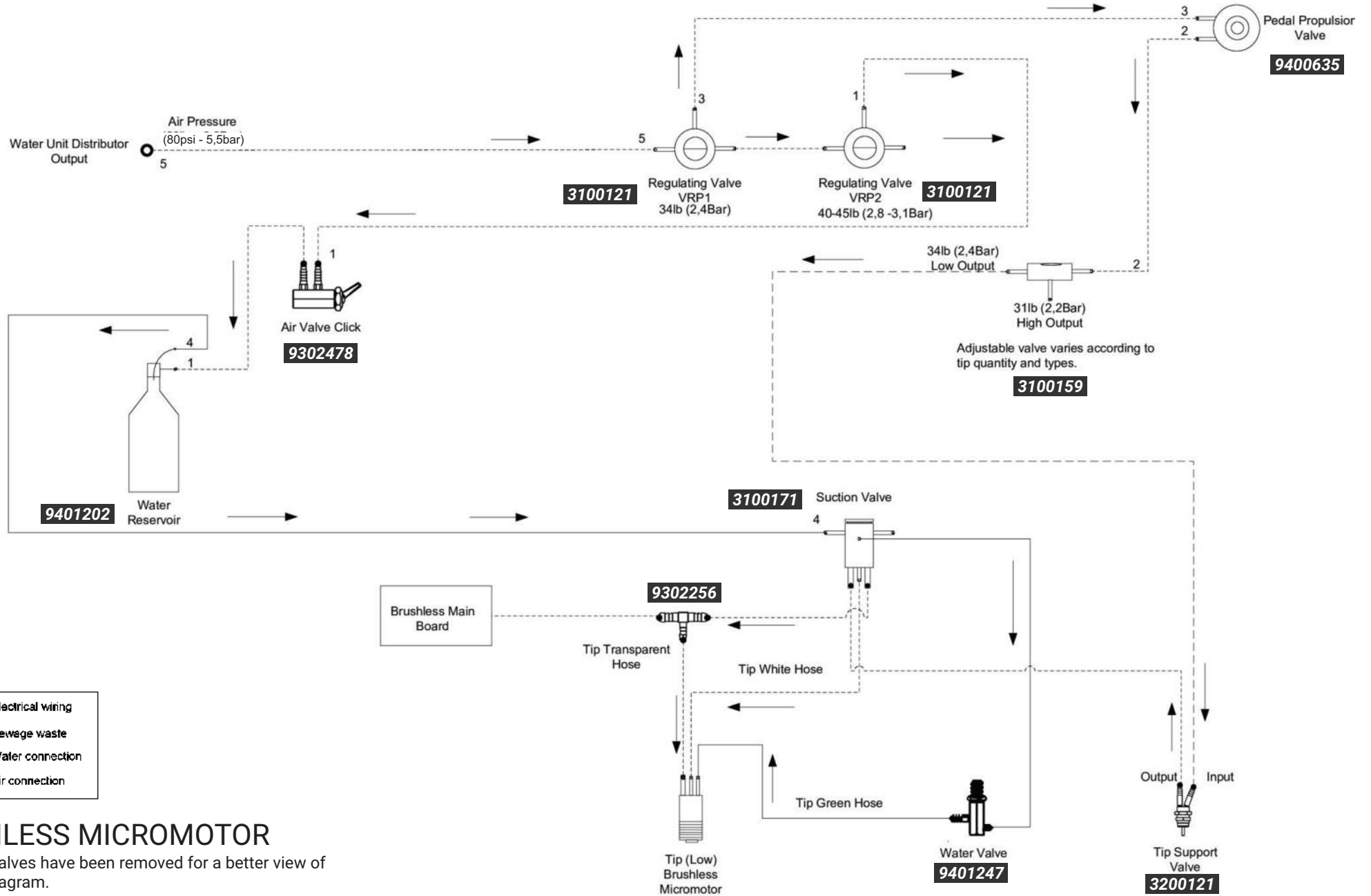

BRUSHLESS MICROMOTOR

All suction valves have been removed for a better view of the wiring diagram.

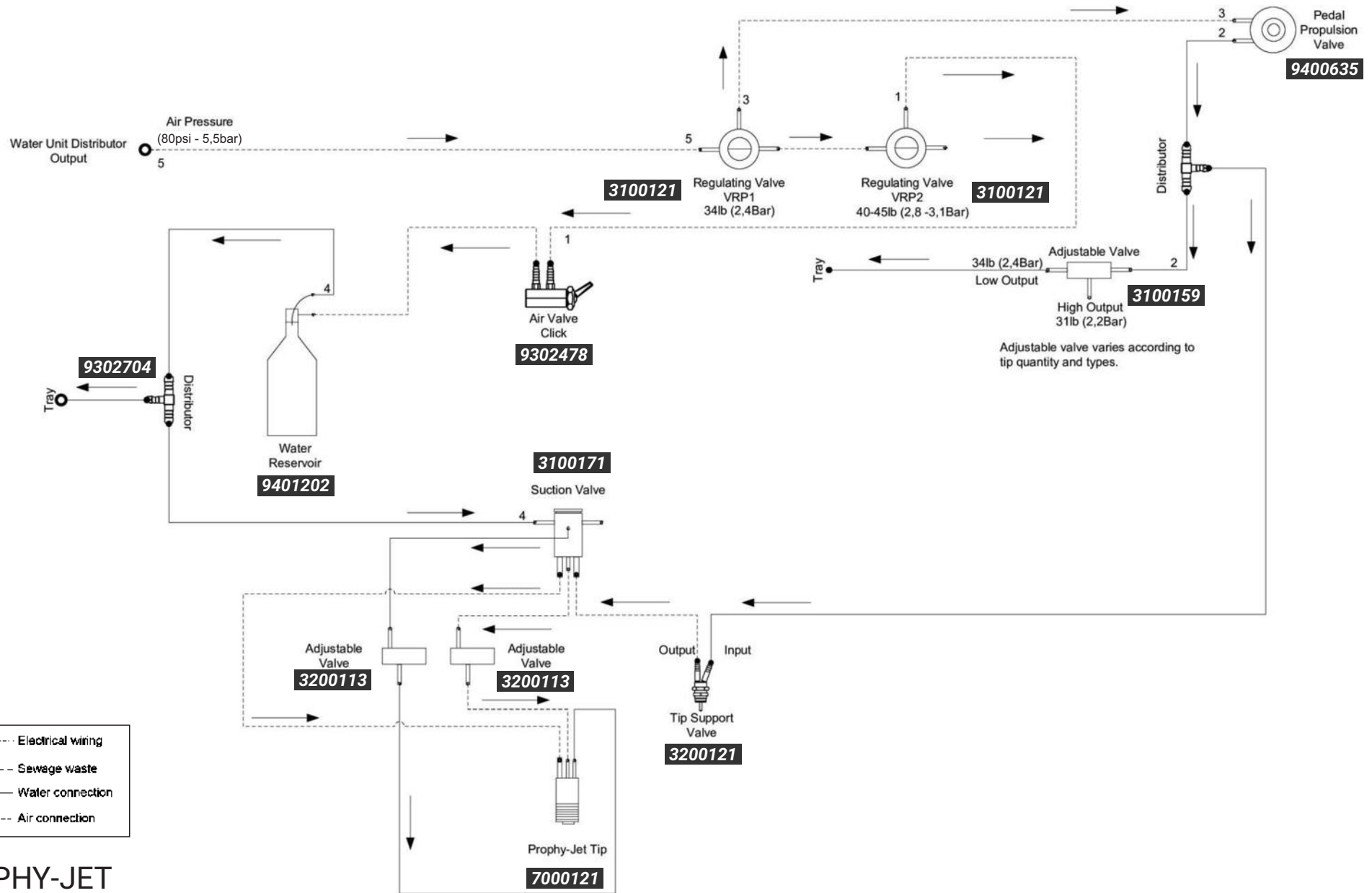

PROPHY-JET

All suction valves have been removed for a better view of the wiring diagram.

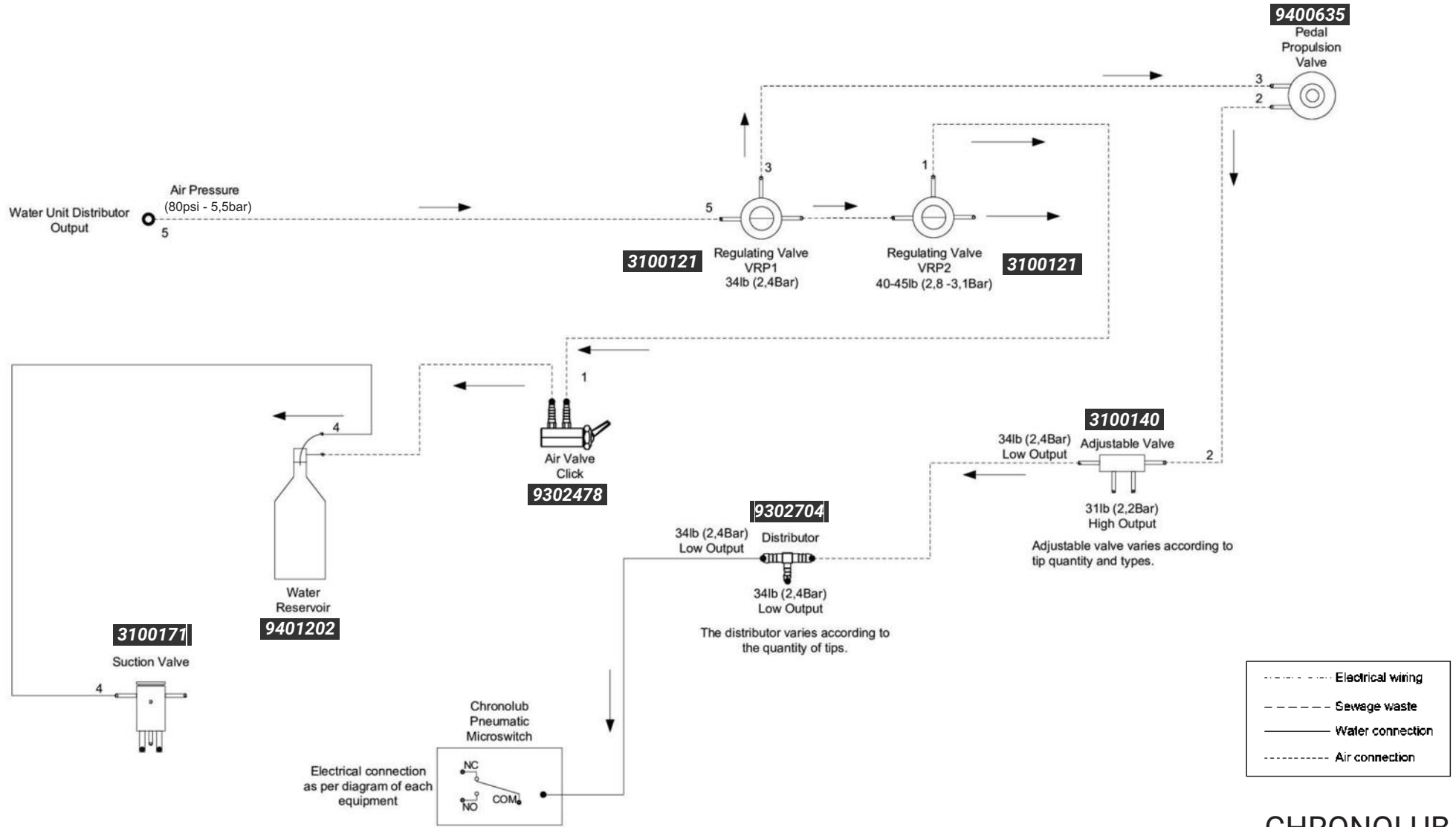

CHRONOLUB

All suction valves have been removed for a better view of the wiring diagram. The low outlet distributor can also be connected to hose 2, depending on the equipment.

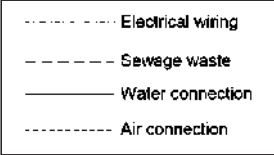
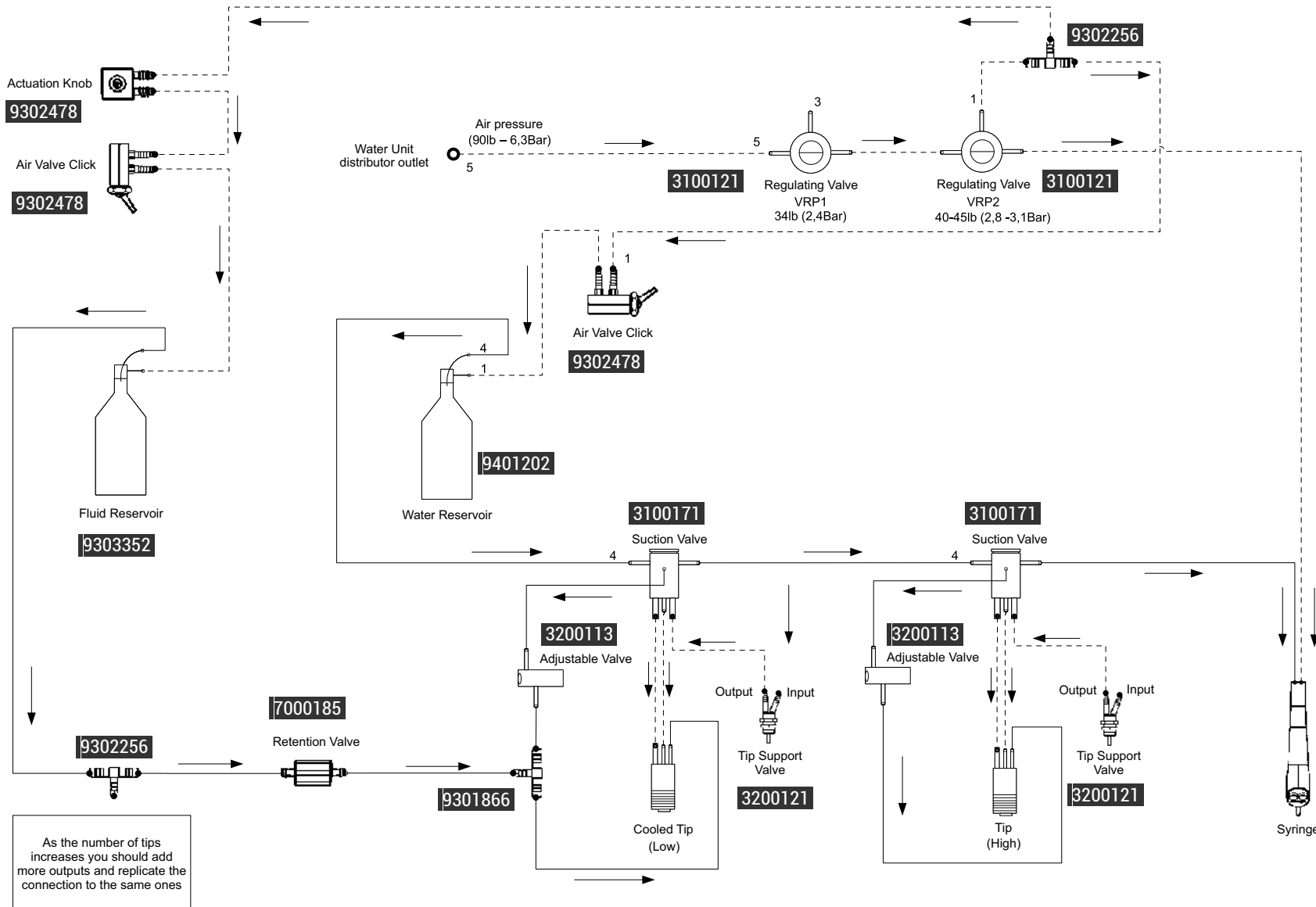

CLEANING SYSTEM

///Olsen

Equipament made to last

OLSEN INDÚSTRIA E COMÉRCIO S.A.

Av. Ivo Lucchi, 68, Distrito Industrial
Palhoça/SC - Brazil - CEP 88133-510

Tel: +55 (48) 2106-6000

www.olsen.odo.br

Certifications:



Olsen Partners:

